

DEPARTMENT OF THE ARMY
TECHNICAL MANUAL

TM 9-8015-^C

DEPARTMENT OF THE AIR
FORCE TECHNICAL ORDER

T 019-75B-2

ORDNANCE MAINTENANCE

ENGINE

(WILLYS-OVERLAND MODEL MD)

AND

CLUTCH FOR

$\frac{1}{4}$ -TON 4 x 4

UTILITY TRUCK

M38A1



DEPARTMENTS OF THE ARMY AND THE AIR FORCE

MARCH 1954

This manual is correct to 1 February 1954

TM 9-8015-1/TO 19-75B-21

(Formerly TM 9-1804-AAI)

TECHNICAL MANUAL DEPARTMENTS OF THE ARMY AND
No. 9-8015-1 THE AIR FORCE

TECHNICAL ORDER

No. 19-75B-21

WASHINGTON 25, D. C., 8 March 1954

**ORDNANCE MAINTENANCE: ENGINE (WILLYS-OVERLAND
MODEL MD) AND CLUTCH FOR 1/4-TON 4 x 4 UTILITY
TRUCK M38A1**

	<i>Paragraphs</i>	<i>Page</i>
CHAPTER 1. INTRODUCTION		
Section I, General -----	1-3	3-7
II. Description and data -----	4-5	7-16
CHAPTER 2. PARTS, SPECIAL TOOLS, AND EQUIPMENT FOR FIELD AND DEPOT MAINTENANCE_	6-9	17-20
3. TROUBLESHOOTING		
I. General -----	10,11	--21,22
II. Engine -----	12-19	22-24
CHAPTER 4. ENGINE		
Section I. Description, operation, and data -----	20-23	25-33
II. Cleaning, inspection, and repair procedures -----	24-29	33-36
III. Disassembly of engine into subassemblies -----	30-49	36-52
IV. Rebuild of cylinder block assembly -----	50-52	52-60
V. Rebuild of cylinder head assembly -----	53-55	60-67
VI. Rebuild of rocker arms and shaft assembly -----	56-58	67-72
VII. Rebuild of connecting rod and piston assemblies_	59-61	72-80
VIII. Rebuild of intake and exhaust valve tappets -----	62,63	80,81
IX. Rebuild of crankshaft -----	64,65	--81
X. Rebuild of camshaft -----	66,67	--82
XI. Rebuild of flywheel assembly -----	68-70	82-84
XII. Rebuild of oil strainer assembly -----	71-73	84,85
XIII. Rebuild of water pump assembly -----	74-76	85-89
XI V. Rebuild of oil pump assembly -----	77-79	89-95
XV. Rebuild of engine rear mounting plate -----	80-82	95,96
XVI. Rebuild of timing gear cover assembly -----	83-85	96,97
XVII. Inspection, repair, and rebuild of associated parts. _	86-93	97-103
XVIII. Assembly of engine from subassemblies -----	94-124	103-142
XIX. Engine run-in tests and adjustments -----	125,126	--142
CHAPTER 5. CLUTCH ASSEMBLY		
Section I. Description and data -----	127,128	143,144
II. Disassembly of pressure plate with cover assem- bly -----	129,130	144,145
III. Cleaning, inspection, and repair of clutch assem- bly -----	131,132	----146
IV. Assembly of pressure plate with cover assembly.. _	133,134	146,147

CHAPTER 6. UNDERWATER ENGINE VENTILATING SYSTEM

	<i>Paragraphs</i>	<i>Pages</i>
Section - - I. Description and operation - - - -	135-137	148-155
II. Rebuild of engine ventilating system - - - - -	138-140	155-158
CHAPTER 7. REPAIR AND REBUILD STANDARDS - - -	141-152	159-169
APPENDIX - - - REFERENCE - - - - -	-	170
INDEX - - - - -		173

CHAPTER 1

INTRODUCTION

Section I. GENERAL

1. Scope

a. This manual is published for the information and guidance of personnel responsible for field and depot maintenance of this materiel. It contains information on maintenance which is beyond the scope of the tools, equipment, or supplies normally available to using organizations. This manual does not contain information which is intended primarily for the using organization, since such information is available to ordnance maintenance personnel in the pertinent operator's technical manual or field manual.

b. This manual contains a description of and procedures for removal, disassembly, inspection, repair, rebuild, and assembly of the Willys-Overland Model MD engine and clutch as used in the power plant (figs. 1 and 2) of the $\frac{1}{4}$ -ton 4 x 4 utility truck M38A1. The appendix contains a list of current references, including supply manuals, technical manuals, and other available publications applicable to the materiel.

c. TM 9-804A contains operating and lubricating instructions for the materiel and contains all maintenance operations allocated to using organizations in performing maintenance work within their scope.

d. Information on the power train will be contained in TM9-8015-2, "Power Train, Body and Frame for $\frac{1}{4}$ -ton 4 x 4 Utility Truck M38A1", when published.

e. **TM 9-804A** contains information on the removal and installation of the engine.

f. TM 9-8627 contains service information on the Delco-Remy starter, generator, distributor, and generator regulator.

g. TM 9-1825B contains service information on the Auto-Lite starter, generator, distributor, and generator regulator.

h. **TM 9-1826A** contains service information on the Carter carburetor.

i. TM 9-1828A contains service information on the AC fuel pump.

j. The first edition is being published in advance of complete technical review of all concerned. Any errors or omissions will be brought to the attention of Chief of Ordnance, Washington 25, D. C., ATTN : ORDFM—Pub.

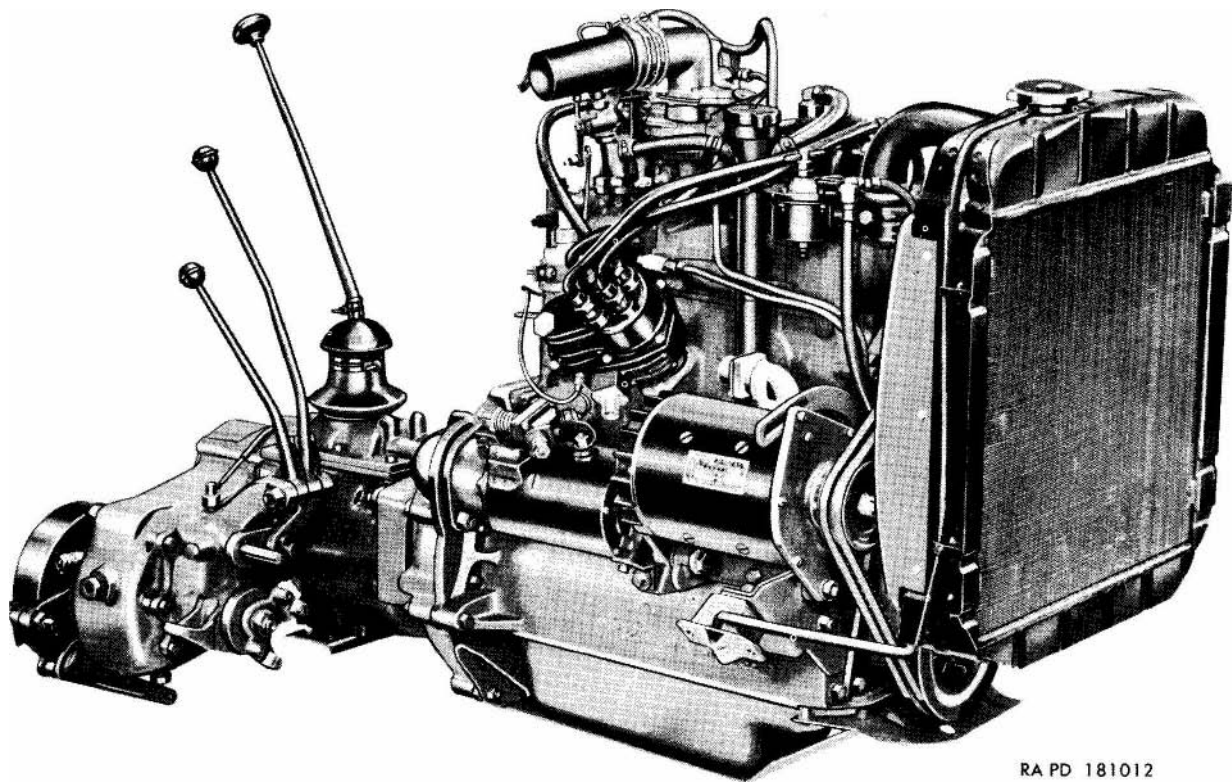

RA PD 181012

Figure 1. Power plant—three-quarter right front view.

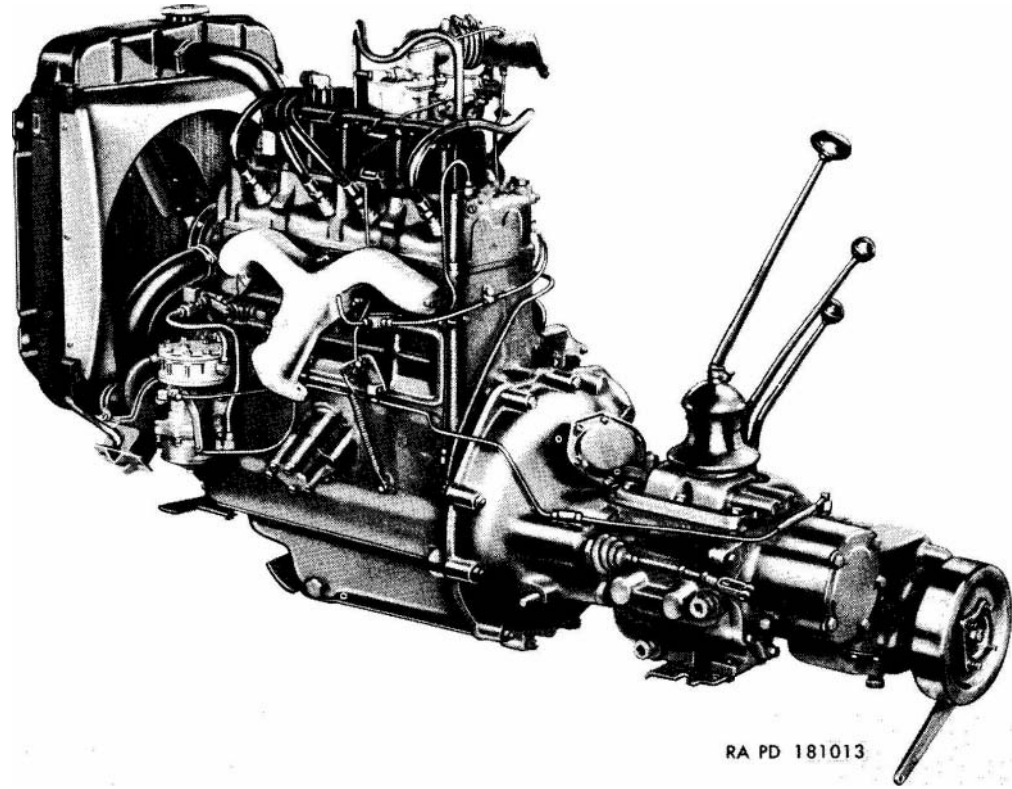

RA PD 181013

Figure 2. Power *plant*—*three-quarter* left rear view.

2. Field and Depot Maintenance Allocation

The publication of instructions for complete disassembly and re-build is not to be construed as authority for the performance by field maintenance units of those functions which are restricted to depot shops and arsenals. In general, the prescribed maintenance responsibilities will be reflected in the allocation of maintenance parts listed in the appropriate columns of the current ORD 8 supply manual pertaining to this vehicle. Instructions for depot maintenance are to be used by maintenance companies in the field only when the tactical situation makes the repair functions imperative. Supply of parts listed in the depot guide column of ORD 8 supply manuals will be made to field maintenance only when the emergency nature of the maintenance to be performed has been certified by a responsible officer of the requisitioning organization and upon express authorization by the chief of the service concerned. Those operations which can be performed as "emergency field maintenance" are specifically covered as such in this manual.

3. Forms, Records, and Reports

a. General. Responsibility for the proper execution of forms, records, and reports rests upon the officers of all units maintaining this equipment. However, the value of accurate records must be fully appreciated by all persons responsible for their compilation, maintenance, and use. Records, reports, and authorized forms are normally utilized to indicate the type, quantity, and condition of materiel to be inspected, to be repaired, or to be used in repair. Properly executed forms convey authorization and serve as records for repair or replacement of materiel in the hands of troops and for delivery of materiel requiring **further** repair to ordnance shops in arsenals, depots, etc. The forms, records, and reports establish the work required, the progress of the work within the shops, and the status of the materiel upon completion of its repair.

b. Authorized Forms. The forms generally applicable to units maintaining this equipment are listed in the appendix. No forms other than those approved for the Department of the Army will be used. For current and complete listing of all forms, refer to SR 310-20-6. Additional forms applicable to the using personnel are listed in the operator's manual. For instructions on use of these forms, see FM 9-10.

c. Field Reports of Accidents. The reports necessary to comply with the requirements of the Army safety program are prescribed in detail in the SR ~~385-10-40~~ series of special regulations. These reports are required whenever accidents involving injury to personnel or damage to materiel occur.

d. Report of Unsatisfactory Equipment or Materials. Any suggestions for improvement in design and maintenance of equipment and spare parts, safety and efficiency of operation, or pertaining to the application of prescribed petroleum fuels, lubricants, and/or preserving materials, or technical inaccuracies noted in Department of the Army publications, will be reported through technical channels as prescribed in SR 700-45-5 to the Chief of Ordnance, Washington 25, D. C., ATTN : ORDFM, using DA Form 468, Unsatisfactory Equipment Report. Such suggestions are encouraged in order that other organizations may benefit.

Note. Do not report all failures that occur. Report only REPEATED or LECURRENT failures or malfunctions which indicate unsatisfactory design or material. However, reports will always be made in event that exceptionally costly equipment is involved. See also SR 700-45-5 and the printed instructions on DA Form 468.

Section II. DESCRIPTION AND DATA

4. Description and Data

a. The engine assembly (figs. 3-6) described herein is made up of the engine, the clutch, and the various accessories attached to the engine.

b. The engine is an "F"-head type, four cylinder, Willys-Overland gasoline engine. A detailed description of the engine and its principle of operation is covered in paragraphs 20 through 23.

c. The clutch is a single plate, dry disk type, composed of two major units; the pressure plate assembly and the driven plate or disk. A detailed description of the clutch is furnished in paragraphs 127 through 128.

d. The accessories and the functions they perform are discussed and described in TM 9-804A.

e. The engine is designed to operate totally submerged in water. Accordingly, the engine and the accessories are of waterproof construction. Because of their unusual construction, special attention must be given to every phase of the rebuild instructions contained herein.

f. The ventilating system of this engine is unusual to the extent that there are special parts incorporated in the system to meet the requirements of underwater operation. Not all engines are equipped at the factory with the deep water fording ventilating system. The parts of the system can be requisitioned as a kit, if required. This manual deals with the engine completely equipped. The entire underwater ventilating system for deep water fording is described and discussed in paragraphs 135 through 137.

g. Throughout this manual there are frequent references to the front end or rear end and the right side or left side of the engine.

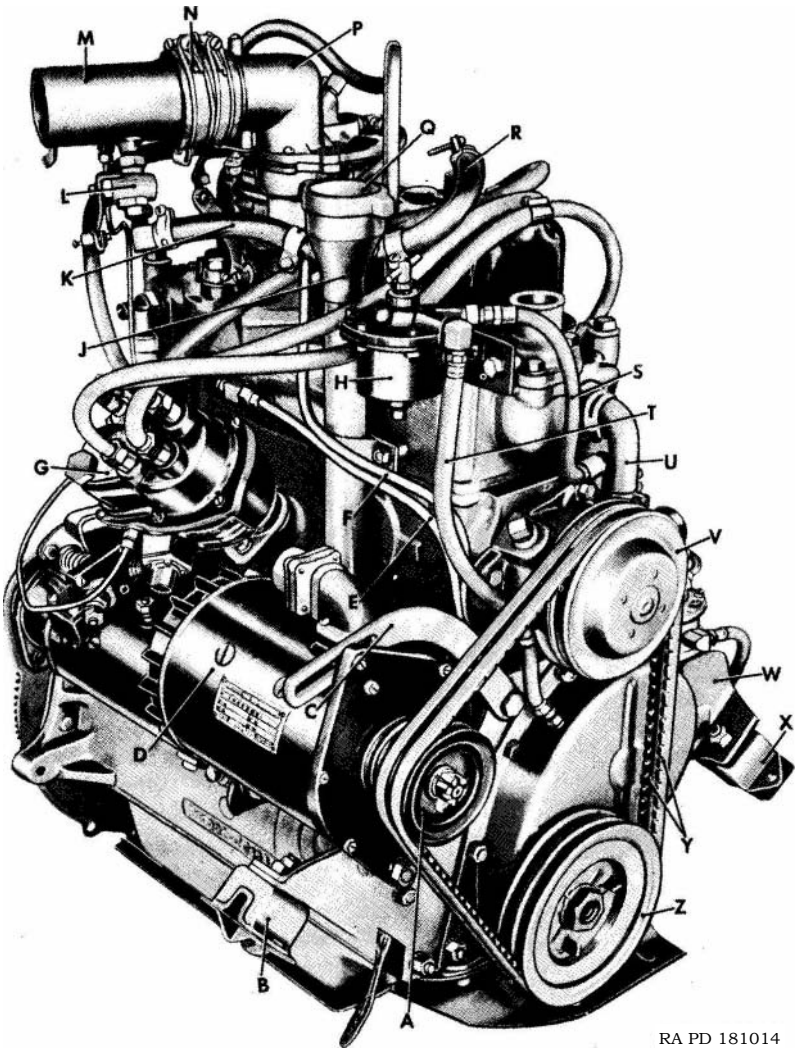

RA PD 181014

Figure 3. Engine with, accessories—three-quarter right front view.

- | | |
|---|---|
| A—Generator drive pulley | N—Carburetor to air intake pipe hose |
| B—Front mounting support cushion | P—Carburetor, assy |
| C—Belt tension adjusting brace | Q—Oil level gage and cap, assy |
| D—Generator, assy | R—Vent hose |
| E—Crankcase vent line | S—Oil filter inlet flexible line, assy |
| F—Carburetor to fuel pump line | T—Oil filter outlet flexible line, assy |
| G—Distributor , assy | U—Water pump bypass tube |
| H—Oil filter, assy | V—Fan and water pump drive pulley |
| J—Oil filler pipe | W—Front mounting plate |
| K—Vent hose | X—Front mounting support cushion |
| L—Crankcase upper vent control valve | Y—Fan and generator drive belts |
| M—Air intake pipe, assy | Z—Fan and generator drive pulley |

Figure 3.—Continued

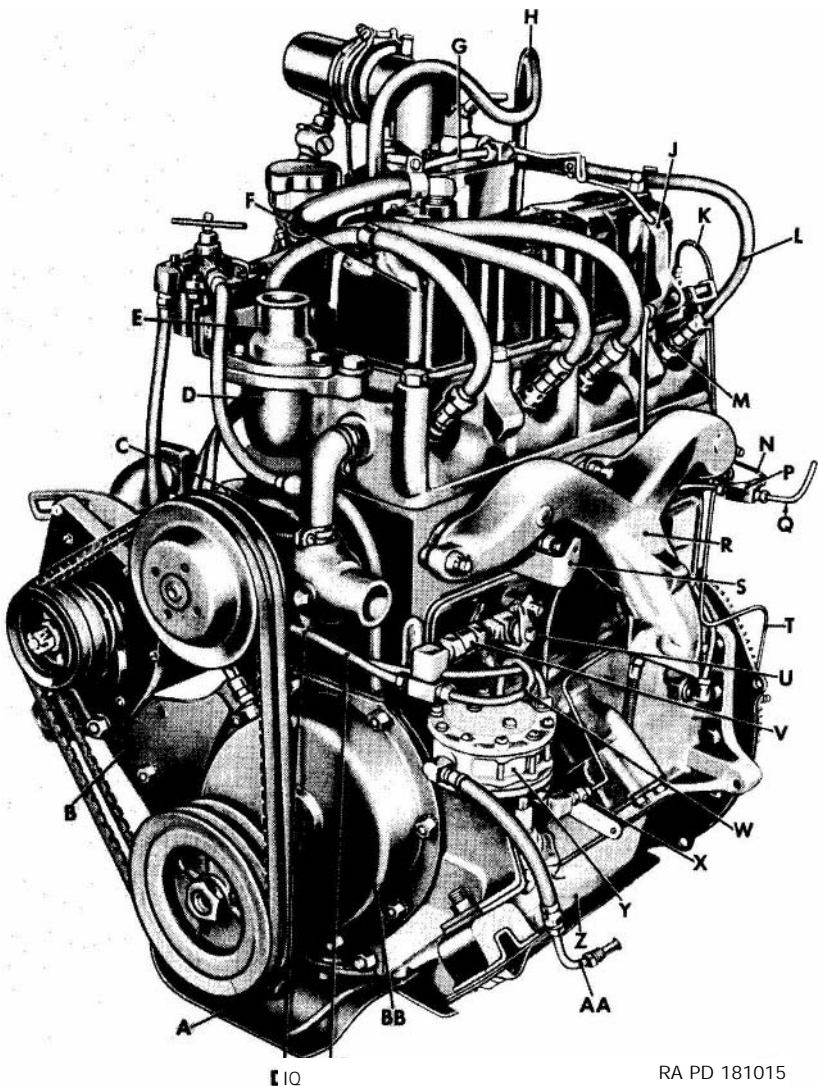

10

RA PD 181015

Figure 4. Engine with accessories—three-quarter left front view.

- | | |
|---|--|
| A—Fan and generator drive pulley shield | P— $\frac{1}{4}$ in., inv flared tube tee |
| B—Front mounting plate | Q—Windshield wiper to tee vent line |
| C—Water pump, assy | R—Exhaust manifold |
| D—Cylinder head | S—Dual control support bracket |
| E—Thermostat housing | T— Oil pressure line |
| F—Rocker arm cover | U—Crankcase lower vent control valve |
| G—Carburetor to fuel pump line | V—Crankcase vent metering valve |
| H—Engine lifting bracket | W—Fuel pump vent line |
| J—Accelerator upper bellcrank | X—Ball check connector |
| K—Crankcase to cylinder head oil line | Y—Fuel pump, assy |
| L—Spark plug cable | Z--Oil pan, assy |
| M—Spark plug | AA—Fuel pump inlet flexible line |
| N—Distributor to windshield wiper fitting vent line | BB—Timing gear cover |
| | CC—Crankcase vent line |
| | DD—Crankcase vent line clip |

Figure 4.—Continued

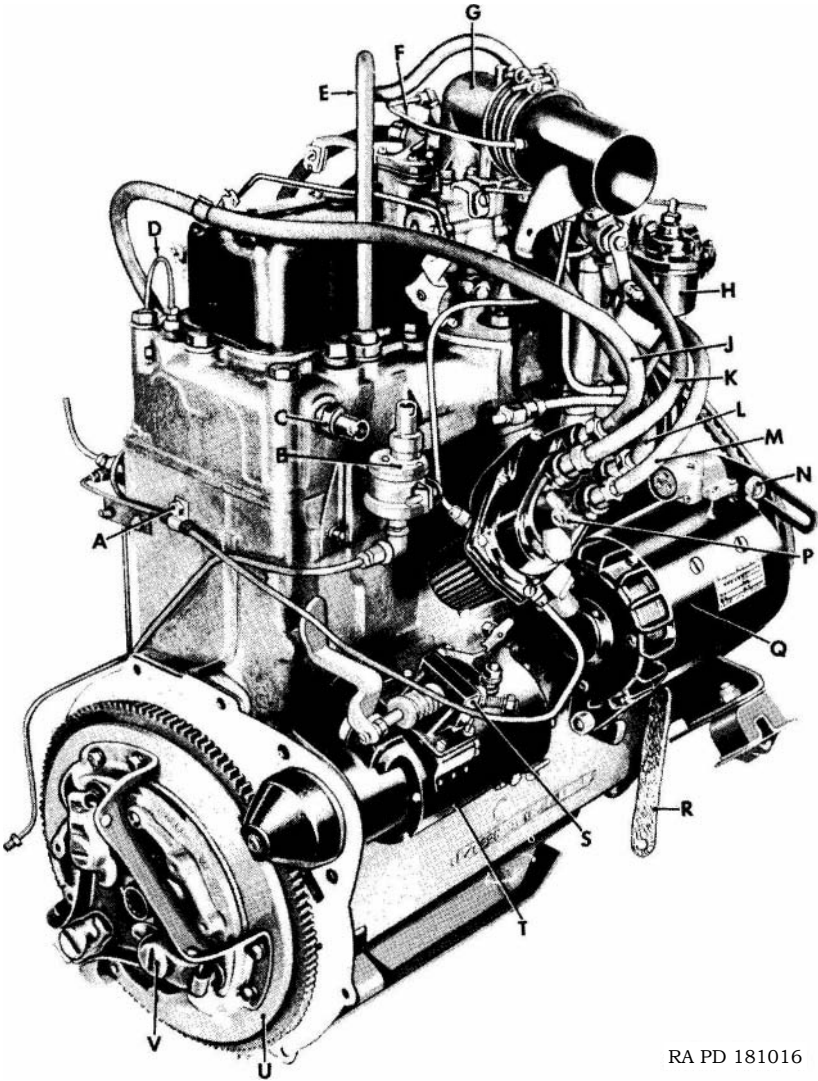

RA PD 181016

Figure 5. Engine with accessories—three-quarter right rear view.

- | | |
|---|---|
| A—Lockwasher cap screw | L—Spark plug cable (No. 3 distributor post to No. 3 spark plug) |
| B—Oil pressure sending unit | M—Spark plug cable (No. 1 distributor post to No. 1 spark plug) |
| C—Water temperature sending unit | N—Belt tension adjusting brace |
| D—Crankcase to cylinder head oil line | P—Distributor, assy |
| E—Engine lifting bracket | Q—Generator, assy |
| F—Carburetor to air intake pipe vent line | R—Engine ground strap |
| G—Carburetor, assy | S—Starter switch |
| H—Oil filter, assy | T—Starter, assy |
| J—Spark plug cable (No. 4 distributor post to No. 4 spark plug) | U—Flywheel, assy |
| K—Spark plug cable (No. 2 distributor post to No. 2 spark plug) | V—Clutch, <i>assy</i> |

Figure 5.—Continued

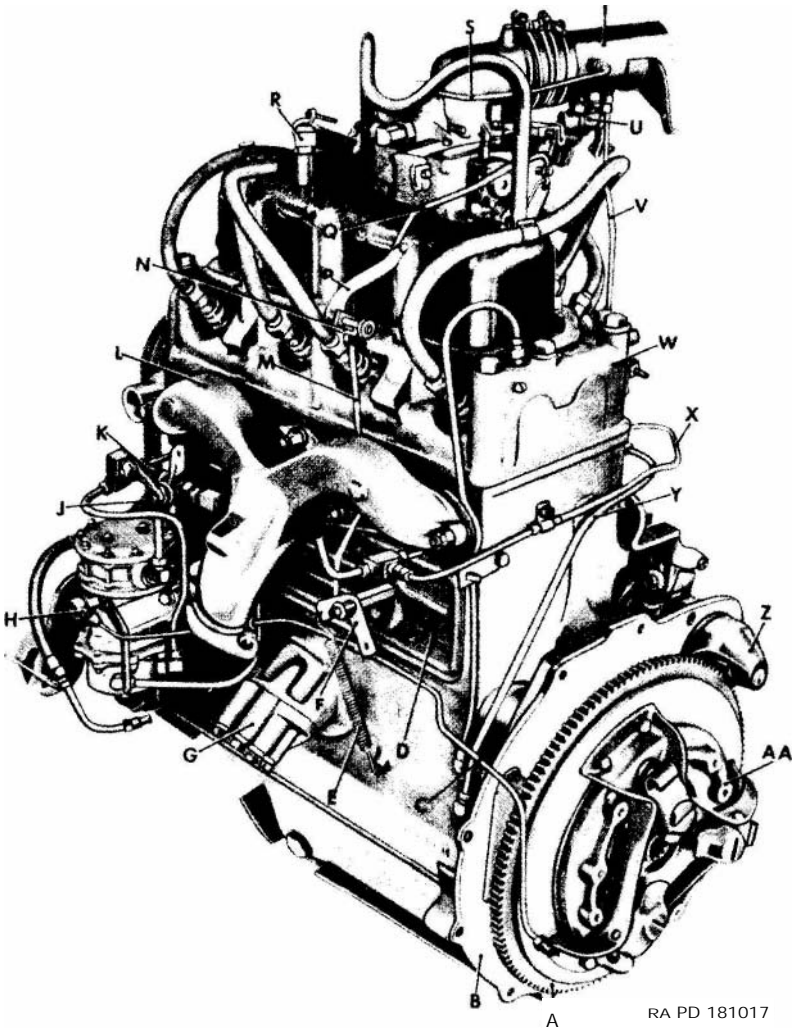

Figure 6. Engine with accessories—three-quarter left rear view.

A—Flywheel, assy	Q—Throttle rod
B—Rear mounting plate	R—Rocker arm cover elbow
C—Oil pressure line	S—Carburetor to air intake pipe vent line
D—Exhaust valve spring compartment cover	T—Air intake pipe, assy
E—Accelerator pedal retracting spring	U—Crankcase upper vent control valve
F—Accelerator lower bellerank	V—Distributor to air intake pipe vent line
G—Oil pump, assy	W—Cylinder head
H—Ball check connector	X—Distributor to windshield wiper tee vent line
J—Crankcase lower vent control valve	Y—Oil pressure sending unit oil line
K—Crankcase metering valve	Z—Starter, assy
L—Exhaust manifold	AA—Clutch, assy
M—Accelerator bellerank link rod	
N—Accelerator bellerank bracket	
P—Accelerator upper bellerank	

Figure 6.—Continued

These terms, as they are used in the manual, have the following meanings :

- (1) The "rear end" of the engine is the end on which the flywheel is mounted.
- (2) The "front end" is the end on which the timing gears are mounted.
- (3) The terms "right" and "left," as used with reference to the engine, are as viewed from the rear end of the engine looking toward the front end.

5. Data

Type	"F"-head, internal combustion gasoline engine
Manufacturer	Willys-Overland
Number of cylinders (in line)	4
Model	MD
Bore	3% in
Stroke	4% in
Compression ratio	7.4 to 1
Used in vehicle model	M38A1
Dry weight complete with flywheel and accessories	499.65 lb
Dry weight complete with flywheel, less accessories	365.15
Maximum brake horsepower	72 at 4,000 rpm
Maximum torque	114 lb-ft at 2,000 rpm

CHAPTER 2

PARTS, SPECIAL TOOLS, AND EQUIPMENT FOR FIELD AND DEPOT MAINTENANCE

6. General

Tools and equipment and maintenance parts over and above those available to the using organization are supplied to ordnance field maintenance units and depot shops for maintaining, repairing, and/or rebuilding the materiel.

7. Parts

Maintenance parts are listed in Department of the Army Supply Manual ORD 8 SNL G-758 which is the authority for requisitioning replacements. Parts not listed in the ORD 8 manual, but required by depot shops in rebuild operations may be requisitioned from the listing in the corresponding ORD 9 manual and will be supplied if available. Requisitions for ORD 9 parts will contain a complete justification of requirements.

8. Common Tools and Equipment

Standard and commonly used tools and equipment having general application to this materiel are listed in ORD 6 SNL J-8, Sections 7, 12, 13 and 18; ORD 6 SNL J-9, Sections 1, 2, 3, 8 and 10; and **ORD 6 SNL J-10**, Sections 4, 7, 8, 11, 12 and 15 and are authorized for issue by T/A and T/O & E.

9. Tools and Equipment

a. Special Tools and Equipment (fig. 7). The special tools and equipment tabulated in table I are listed in Department of the Army Supply Manual **ORD 6 SNL J-16**, Section 38. This tabulation contains only those special tools and equipment necessary to perform the operations described in this manual, is included for information only, and is not to be used as a basis for requisitions.

h. Improvised Tools. The improvised tools listed in table II and the dimensioned detail drawings shown in figure 8 apply only to field and depot shops in order to enable these maintenance organizations to fabricate these tools locally, *if* desired. These tools are of chief value to maintenance organizations engaged in rebuilding a large number of identical components ; however, they are not **essen-**

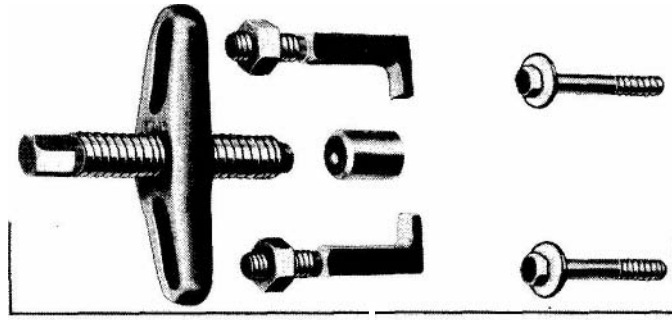

PULLER-41-P-2956-4

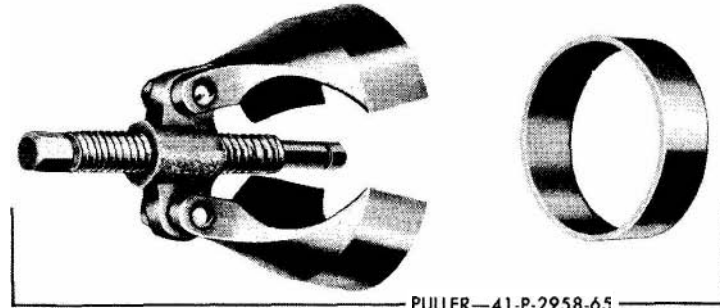

PULLER-41-P-2958-65

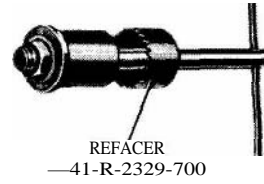

REFACER
—41-R-2329-700

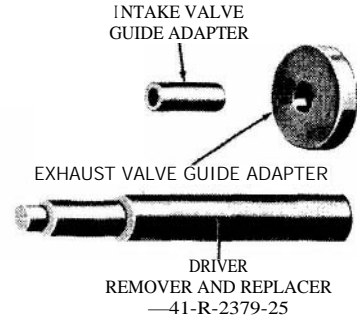

INTAKE VALVE
GUIDE ADAPTER
EXHAUST VALVE
GUIDE ADAPTER
DRIVER
REMOVER AND REPLACER
—41-R-2379-25

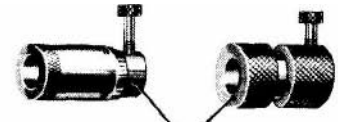

KIT, GAGE—41-K-84-15

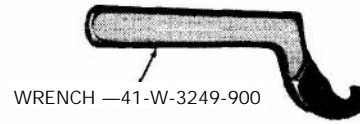

WRENCH —41-W-3249-900

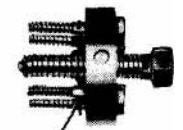

PULLER —41-P-2908-240
RA PD 181018

Figure 7. Special tools and equipment.

tial for rebuild and are not available for issue. The data in table II are furnished for information only.

Table I. Special Tools and Equipment for Field and Depot Maintenance

Item	Identifying No.	References		Use
		Fig.	Par.	
KIT, gage, valve cap clearance checking.	41-K-84-15	7, 66, 67	87	Gaging exhaust valve to exhaust valve rotator cap clearance.
Consisting of:				
GAGE -----	41-C-234-275			
COLLAR -----	41-C-2482-15			
BOX -----	41-B-1862-250			
PULLER, crankshaft and camshaft timing gears.	41-P-2956-4	7, 19	38, 39	Removing camshaft drive and driven gears.
PULLER, water pump impeller.	41-P-2958-65	7, 55	74	Removing water pump impeller.
PULLER, water pump pulley four leg, 3/4-20NC, 1 1/8 in. center distance.	41-P-2908-240	7, 56	74	Used with wrench 41-W-3249-900 for removing water pump pulley.
REFACER, water pump hushing.	41-R-2329-700	7, 57	75	Refacing sealing surface in water pump.
REMOVER AND REPLACER.	41-R-2379-25	7, 28, 36, 37	51, 54	Removing and replacing intake and exhaust valve guides.
WRENCH -----	41-W-2349-900	7, 56	74	Used with puller 41-P-2908-240 for removing water pump pulley.

Table II. Improved Tools for Field and Depot Maintenance

Item	References		Use
	Fig.	Par.	
GAGE, checking, clutch pressure plate release lever.	8, 103	123	Checking position of pressure plate release levers.
REMOVER AND REPLACER, piston pin.	8, 48	59, 61	Removing or replacing piston pins.
REMOVER AND REPLACER, camshaft front bearing.	8, 32	50, 52	Removing or replacing camshaft front bearings.
SEATING TOOL, expansion plug.	8, 31	52	Seating expansion plugs in cylinder block.

CLUTCH PRESSURE PLATE RELEASE
LEVER CHECKING GAGE

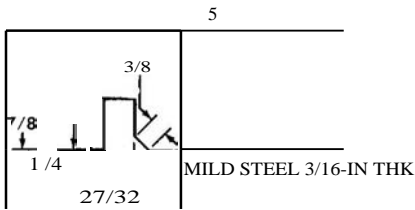

PISTON PIN REMOVER
AND REPLACER

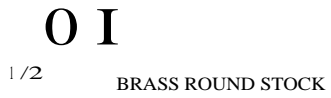

2.220

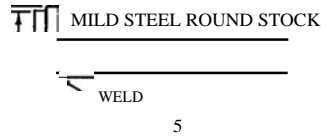

CAMSHAFT FRONT BEARING
REMOVER AND REPLACER

RA PD 181019

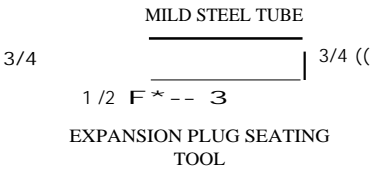

EXPANSION PLUG SEATING
TOOL

NOTE: ALL DIMENSIONS
SHOWN ARE IN INCHES

Figure 8. Improvised tools.

CHAPTER 3

TROUBLESHOOTING

Section 1. GENERAL

10. Purpose

Note. Information in this chapter is for use of ordnance maintenance personnel in conjunction with and as a supplement to the troubleshooting section in the pertinent operator's manual. It provides the continuation of instructions where a remedy in the operator's manual *refers* to ordnance maintenance personnel for corrective action.

Operation of a deadlined vehicle without a preliminary examination can cause further damage to a disabled component and possible injury to personnel. By careful inspection and troubleshooting, such damage and injury can be avoided and, in addition, the causes of faulty operation of a vehicle or component can often be determined without extensive disassembly.

11. General Instructions and Procedures

This chapter contains inspection and troubleshooting procedures to be performed while a disabled component is still mounted in the vehicle or after it has been removed.

a. The inspections made while the component is mounted in the vehicle are for the most part visual and are to be performed before attempting to operate the vehicle. The object of these inspections is to avoid possible damage or injury and also to determine the condition of and, when possible, what is wrong with the defective component.

b. The troubleshooting performed while the component is mounted in the vehicle is that which is beyond the normal scope of the using organization. Check the troubleshooting section of TM 9-804A then proceed as outlined in this chapter. These troubleshooting operations are used to determine if the fault can be remedied without removing the component from the vehicle and also, when subsequent removal is necessary, to indicate when repair can be made without complete disassembly of the component.

c. Inspection after the component is removed from the vehicle is performed to verify the diagnosis made when the component was in the vehicle, to uncover further defects, or to determine faults if the component alone is received by the ordnance establishment. This

inspection is particularly important in the last case because it is often the only means of determining the trouble without completely disassembling the component.

d. Troubleshooting a disabled component after it has been removed from a vehicle consists of subjecting it to tests on a dynamometer. This chapter discusses those symptoms which can be diagnosed by using the testing equipment and interprets the results in terms of probable causes. Information on final testing of the engine is contained in TB ORD 215.

Section II. ENGINE

12. General

Most engine troubles are actually accessory troubles. These accessories are fully covered in the pertinent manuals listed in paragraph 1. The design and mounting of the engine covered in this manual permits very complete troubleshooting while the engine is mounted in the vehicle. Remedies and procedures are discussed in detail in TM 9-804A. Some corrective procedures, beyond the normal scope of using organization, can be performed while the engine is mounted ; some require the removal of the power plant from the vehicle. A good rule to follow in locating engine trouble is to make no more than one adjustment at a time.

13. Seized Engine Parts

If starting system is operative but **engine** refuses to turn over, remove the starting motor and spark plugs. Depress the clutch pedal and block the pedal to hold the clutch in the disengaged position. Attempt to turn the crankshaft using a medium length screwdriver or other small pry-bar inserted into the starter mounting hole and engaged between the teeth of the flywheel.

Note. Do not attempt to force the crankshaft over. Only a moderate amount of pressure is required to determine whether or not the engine is bound.

If this check indicates the engine to be abnormally tight or immovable, the engine must be completely disassembled to determine the initial cause of the trouble and to permit inspection for any secondary damage that may have occurred as a result of the seizure.

14. Sticking Valves

If engine operates but stalls frequently or lacks power, stop the engine and remove the valve covers. Turn the crankshaft over, as necessary, to bring each valve in turn to its closed position. Using a screwdriver or other comparable tool, press firmly against the lower end of the valve to cause it to move to its open position. Quickly withdraw the screwdriver and note the action of the valve as it returns to its closed position. It should return to the closed position with a definite

snap. A valve which fails to close or one which has a sluggish return action is either bent or broken, or fouled with carbon and/or gum deposits. In either case the valve or valves must be removed from the engine and the valve and guide either cleaned or replaced.

15. Improper Ignition or Preignition

If engine operates satisfactorily but "pings" or knocks when accelerated and/or continues to fire after ignition switch is turned off, remove the distributor and check the automatic spark advance mechanism against specifications ; TM 9-1825A for Delco-Remy distributor; TM 9-8627 for Auto-Lite distributor. If complaint is still not corrected, remove the cylinder head and scrape carbon formations from inside surface of cylinder head and top of cylinder block.

16. Low or Unequal Compression in All Cylinders

If engine operates but compression test reveals poor compression in one or more cylinders, improperly seating valves, worn cylinders, worn piston rings, or a leaky head gasket can be the cause of low or unequal compression readings. To narrow down these probable causes proceed as follows :

- a. Remove the spark plugs from all cylinders.
- b. Pull the throttle control out to the wide open position.
- c. Insert a conventional type compression gage into the spark plug opening of one of the cylinders and crank the engine with the starter. Note and record the highest compression reading obtained.
- d. Repeat the procedure on all four cylinders and compare the readings obtained upon completion of the operation.
- e. Normal compression pressure is 135 psi at cranking speed of 185 rpm. The minimum allowed pressure reading is 100 psi. The readings should not vary more than 20 psi between cylinders.
- f. Squirt one shot of heavy engine oil (SAE -50) into the cylinders having a low reading (one at a time) using a trigger operated hand oiler. The heavy oil will work into the ring grooves in the piston and help to seal the cylinder against compression leaks. Repeat the compression test on these cylinders. If these readings are not higher than the initial readings, it indicates that poorly seating valves are the fault. If the pressure increases, it indicates that worn rings, worn cylinders, or a leaking head gasket is the fault.
- g. When the cause of the trouble has been determined, refer to the pertinent sections of this manual and proceed with the repair as instructed therein.

17. Leaking Valves

If engine operates but stalls frequently or lacks power, refer to paragraph 14.

18. Excessive Carbon in Engine

Carbon is the residue that results from the incomplete combustion of engine lubricating oil. When found in excessive amounts in the combustion chamber of an engine, it indicates that the piston rings or cylinders have become worn beyond limits. Refer to paragraph 51b(3) for method of determining wear of cylinders, and paragraphs 59 through 61 for procedures on piston ring replacement.

19. Excessive Oil Consumption

The excessive consumption of oil is an indication that the piston rings or cylinders have become worn beyond limits or that the clearance between inlet valve stems and guides is excessive. Refer to paragraph 51b(3) for method of determining wear of cylinders, paragraphs 59 through 61 for procedures on piston ring replacement, and paragraph 54b (5) for methods of checking clearance between valves and stems.

CHAPTER 4

ENGINE

Section I. DESCRIPTION, OPERATION, AND DATA

20. Description

a. The Willys-Overland Model MD engine is an F-head type engine; which is a combination valve-in-head and valve-in-block type. For explanation of the construction features of the engine, refer to paragraph 21.

b. This engine is designed and waterproofed, as are all of the accessories, for underwater operation. The engine will operate partially submerged without extra equipment, but when it is to be operated completely submerged, the air intake and exhaust openings must be fitted with tube extensions to extend these openings above the surface of the water in which the vehicle is operated. Two shutoff valves, manually controlled by the operator of the vehicle, are included in the engine ventilating system and closed during the time the engine is operated partially or completely submerged. Refer to chapter 6 for an explanation of the principles of operation of the engine ventilating system, and for a description of the parts which make up the complete system.

21. Construction and Operation

a. *General.* The following discussion of the construction and operation of the Model MD engine is referenced to figures 9 and 10, as noted. These views are sectioned to show the details of the operating parts of the engine and deviate from a true cross section to the degree necessary to accomplish their intended purpose.

b. *Crankshaft and Crankshaft Bearings* (fig. 9). The crankshaft (XX) is supported at three points in the cylinder block on replaceable type lower rear, center, and front two halves main bearings (NN, SS, and YY) . The bearings are prevented from rotating in their supports in the cylinder block by dowel pins (**PP, RR, and VV**). Two dowel pins are used in both the center and the rear bearing supports, but only one is used in the front bearing support. The crankshaft front main bearing (YY) is flanged to take the end thrust of the crankshaft. A flanged section on the rear of the crankshaft (XX) acts as an oil slinger and, in combination with the rear main bearing upper and lower oil seal (LL) installed in the rear main bearing

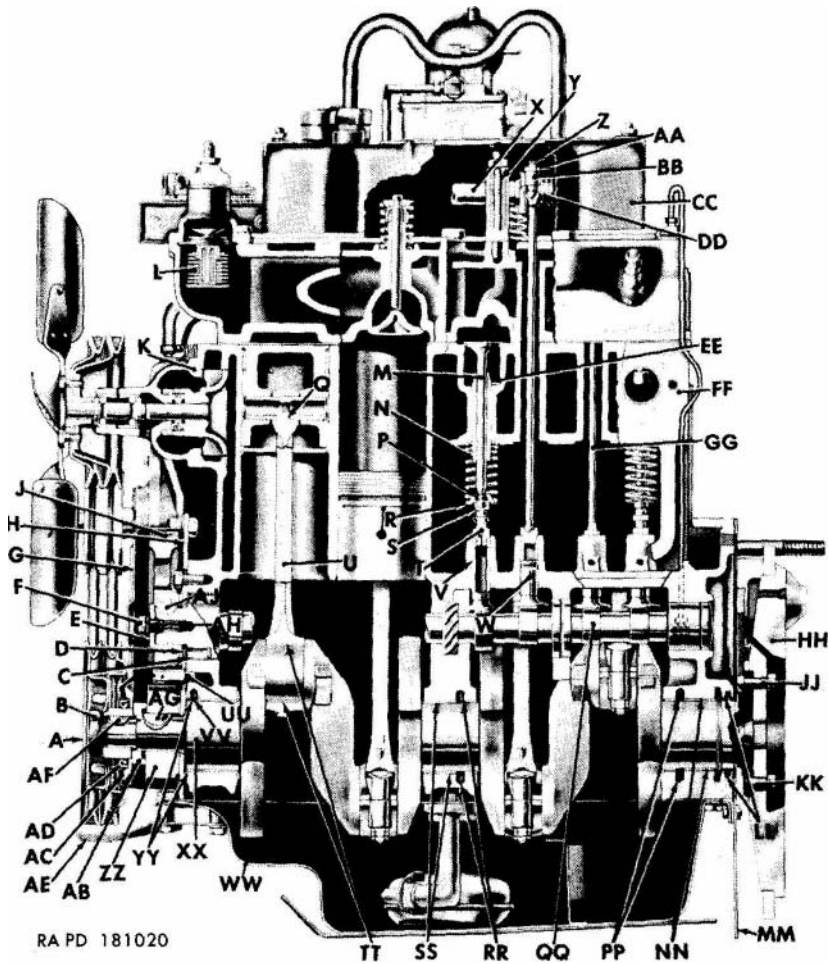
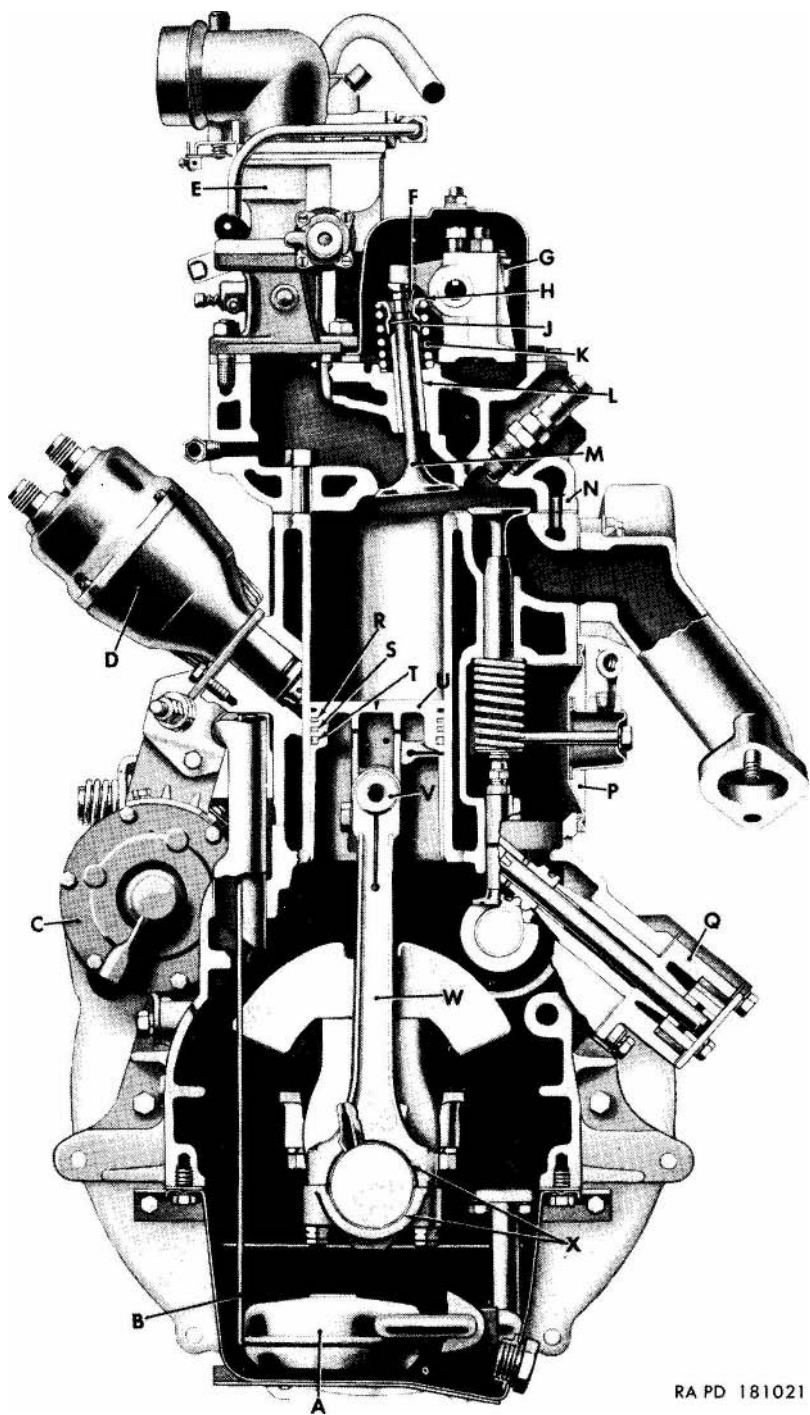

Figure 9. Engine assembly—side sectional view.

- A—Pulley, fan and generator drive-7372558
- B—Nut, $1\frac{1}{16}$ in-7697864
- C—Bearing, bushing type, camshaft, front-7744319
- D—Plate, thrust, camshaft-7351413
- E—Washer, plain, $\frac{1}{2}$ ID, 14 OD-7741406**
- F—Screw, cap, $\frac{1}{16}$ -14NC-3 x 1 $\frac{1}{2}$ -122260
- G—Cover, timing gear—7372576**
- H—Plate, front mounting-7372578
- J—Gear, camshaft driven-7741419
- K—Pump, water, assy-7372806
- L—Thermostat, water temperature-7348571
- M—Valve, exhaust-7375035
- N—Spring, exhaust valve-7371235
- P—Lock, exhaust valve spring retainer-7375033
- Q—Bolt, lock, piston pin-7324840
- R—Retainer, exhaust valve spring-7375034
- S—Cap, exhaust valve rotator-7375032
- T—Screw, adjusting, exhaust valve-7371258
- U—Rod, connecting-7743751
- V—Tappet, exhaust valve-7372585
- W—Tappet, intake valve—WO-800550
- X—Shaft, rocker arm-8329720
- Y—Bracket, rocker arm shaft-8329712
- Z—Screw, adjusting, intake valve-8329718
- AA—Nut, lock, $\frac{3}{16}$ -24NF-2—124920
- BB—Arm, rocker-8329710
- CC—Cover, rocker arm-8329713**
- DD—Spring, rocker arm shaft-8329721
- EE—Guide, exhaust valve-7520738
- FF—Block, cylinder-7412658
- GG—Rod, push, intake valve—8329717
- HH—Flywheel, assy-8328045
- JJ—Bolt, $\frac{3}{8}$ -24NF-2 x 1 $\frac{1}{2}$ -732840
- KK—Dowel, tapered-804367
- LL—Seal, oil, upper and lower, rear main bearing-7372560
- MM—Plate, rear mounting-8328047
- NN—Bearing, two halves, rear, main lower-7371169
- PP—Pin, dowel, bearing-7371229
- QQ—Camshaft-8329698
- RR—Pin, dowel, bearing-7371229
- SS—Bearing, two halves, center, main-7371225
- TT—Bearing, two halves connecting rod-5701528
- UU—Jet, oil, timing gear-7372557
- VV—Pin, dowel, bearing-7371229
- WW—Pan, oil-7371278
- XX—Crankshaft-7744463
- YY—Bearing, two halves, front main-7371170
- ZZ—Gear, crankshaft drive-7741415
- AB—Spacer, *crankshaft drive gear*-7741414
- AC—Slinger, oil, crankshaft-7371161
- AD—Seal, oil, front-7375028
- AE—Shield, fan and generator drive pulley—7371376
- AF—Key, woodruff, $\frac{3}{16}$ x $\frac{3}{4}$ —124549
- AG—Key, woodruff, $\frac{3}{16}$ x 1-124552
- AH—Washer, lock, $\frac{7}{16}$ -inch—136857
- AJ—Key, woodruff, 41 $\frac{1}{2}$ x $\frac{3}{4}$ —124549

Figure 9.—Continued



RA PD 181021

Figure 10. Engine assembly—end sectional view.

support, prevents the leakage of oil from the rear end of the cylinder block. Leakage of oil from the front end of the cylinder block is controlled by the crankshaft oil slinger (AC), and the front oil seal (AD) installed in the timing gear cover (G). The oil seal in the cover bears against the hub of the fan and generator drive pulley (A).

c. *Camshaft and Bearings* (fig. 9). The camshaft is supported at four places in the cylinder block. Only the front support is fitted with a replaceable bushing type bearing (C). A camshaft thrust plate (D) bolted to the front of the cylinder block takes the end thrust of the camshaft. The camshaft actuates the fuel and vacuum pump and the intake and exhaust valve tappets (V and W) by means of integral lobes forged into the shaft proper. Actuation of the distributor (D, fig. 10) is by means of an integral worm gear located at the approximate center of the camshaft.

d. *Timing Gears* (fig. 9). The crankshaft drive gear (ZZ) and the camshaft driven gear (J) are installed on the front end of the crankshaft and the camshaft respectively. These two gears are frequently referred to as the "timing gears". The camshaft driven gear (J) is secured on the front end of the camshaft by means of a cap screw (F) and a plain washer (E). The crankshaft drive gear is secured on the front end of the crankshaft by a nut (B) threaded onto the front end of the crankshaft and also holding the fan and generator drive pulley (A), the crankshaft oil slinger (AC), and the crankshaft drive gear spacer (AB). The timing gear cover (G) incloses the timing gear and provides the mounting for the crankshaft front oil seal (AD).

e. *Pistons and Connecting Rods* (fig. 10). The T-slot aluminum piston (U) is fitted with three rings ; two compression rings (R and S), and one oil control ring (T). The top groove serves as an in-

A—Strainer, oil-7036578	N—Head, cylinder-8328474
B—Gage, oil level, with cap, assy-8328406	P—Cover, exhaust valve compartment-7371237
C—Starter, assy-8328132	Q—Pump, oil, assy-7376907
D—Distributor, with coil, assy-7358569	R—Ring, compression—(part of ring set-7371146)
E—Carburetor, assy-8329774	S—Ring, compression—(part of ring set-7371146)
F—Lock, intake valve spring retainer-7371238	T—Ring, oil control—(part of ring set-7371146)
G—Arm, rocker LH-8329710	U—Piston, with pin, assy-7372873
H—Retainer, intake valve spring-8329683	V—Pin, piston— (part of piston, with pin, assy-7372873)
J—Seal, oil, intake valve spring retainer-8329694	W—Rod, connecting—7743752
K—Spring, intake valve-8329695	X—Bearing, two halves, connecting rod-5701528
L—Guide, intake valve-8329691	
M—Valve, intake-8329697	

Figure 10.—Continued

sulator to protect the three rings below it from the heat generated in the combustion chamber. The upper end of the connecting rod (W) is connected to the piston by means of the piston pin (V). The lower end is bolted around the crankshaft, with a replaceable connecting rod two-halves bearing (X) installed between the connecting rod and the crankshaft.

f. Exhaust Valves and Related Parts (fig. 9). The exhaust valves, (M) which operate in the exhaust valve guides (EE) in the cylinder block (FF), are actuated by the camshaft (QQ) through the exhaust valve tappets (V). Adjustment of exhaust valves is accomplished by means of the exhaust valve adjusting screw (T) threaded into the upper end of the exhaust valve tappets. An exhaust valve rotator cap (S), installed between the lower end of the exhaust valve and the adjusting screw in the tappet, fits loosely on the end of the exhaust valve. On each lift, or opening stroke of a tappet, the tappet first pushes the rotator cap through nominal clearance (par. 87c(2) (a)). The upper end of the rotator cap then contacts the exhaust valve spring retainer locks (P) which in turn pushes up on the exhaust valve spring retainer (R) and the exhaust valve spring (N). With the spring load thus removed from the valve, the valve is free to rotate a slight amount each time it is lifted from its seat in the cylinder block.

g. Intake Valves and Related Parts (fig. 10). The intake valves (M) operate in intake valve guides (L) in the cylinder head (N) and are actuated by means of rocker arms (It below). The rocker arms are actuated by the intake valve push rods (GG, fig. 9), and the intake valve tappets (W, fig. 9). The intake valve springs (K), the intake valve spring retainers (H) and the intake valve spring retainer locks (F) make up the remainder of the valve operating parts. An intake valve spring retainer oil seal (J), which encircles the upper end of the intake valve between the valve locks and the upper end of the valve guide, controls the leakage of oil past the valve stem and along the valve guide.

h. Rocker Arms and Related Parts (fig. 9). The rocker arms (BB) and their related parts are mounted on the top of the cylinder head and inclosed by the rocker arm cover (CC). The rocker arm shaft (X), supported in four rocker arm shaft brackets (Y), carries the rocker arms (BB) and the rocker arm shaft springs (DD). The intake valves adjusting screws (Z) and locknuts (AA) provide the means for adjusting the intake valves (par. 114).

i. Flywheel (fig. 9). The flywheel assembly (HH) is attached to the rear end of the crankshaft by means of two tapered dowels (KK) and four standard bolts (JJ).

j. Engine Front and Rear Mounting Plates (fig. 9). The front mounting plate (H) and the rear mounting plate (MM), bolted to

their respective ends of the engine, inclose and seal the ends of the cylinder block (FF). The front plate provides the mounting surface for the attachment of the front mounting support cushion and the rear plate forms the mounting surface for the flywheel housing.

k. *Oil Pan and Fan and Generator Drive Pulley Shield* (fig. 9). The oil pan (WW), in addition to serving as a reservoir for the engine oil, also serves as an engine base. A permanently attached sheet metal plate extending the full length of the pan reinforces it and protects the underside against damage from contact with solid objects which may be encountered in rough terrain. In a like manner, the fan and generator drive pulley shield (AE) , extending forward from the front end of the engine, gives protection to the fan and generator drive pulley (A) mounted on the front end of the crankshaft.

l. *Water Pump* (fig. 9). The water pump assembly (K), bolted to the front end of the engine, circulates the coolant through the vehicle cooling system. During the warmup period, however, and before the water temperature thermostat (L), mounted in the cylinder head, opens, a small percentage of the coolant circulates only within the cylinder head and cylinder block through the bypass hose, to provide a rapid warmup.

m. *Information on Accessories*. For operating or construction details of the accessory assemblies or subassemblies which are furnished with the engine refer to TM 9-804A, or to the paragraphs within this manual that apply.

22. Engine Lubrication System

(fig. 11)

a. Lubrication of the engine is by means of a force feed, continuous circulating system. A planetary gear type oil pump is located on the left side of the engine and driven by the integral gear on the camshaft. Oil is drawn into the circulating system through a floating type oil strainer.

b. This floating type oil strainer does not permit water or dirt to be picked up and sent through the engine bearings because the oil is drawn horizontally from the top level of the oil, leaving any dirt and water in the bottom of the oil pan. Oil pressure is maintained under any and all driving or climatic conditions.

c. Oil is forced to the crankshaft and the camshaft bearings through drilled passages in the cylinder block and to the connecting rod bearings through drilled passages in the crankshaft.

d. An oil jet, threaded into a hole in the front of the cylinder block, provides a positive spray lubrication to the timing gears.

e. Oil sprayed from a drilled hole in the end of each connecting rod lubricates the cylinder walls, the pistons, the piston pins, the exhaust valve mechanism, and the intake and exhaust valve tappets.

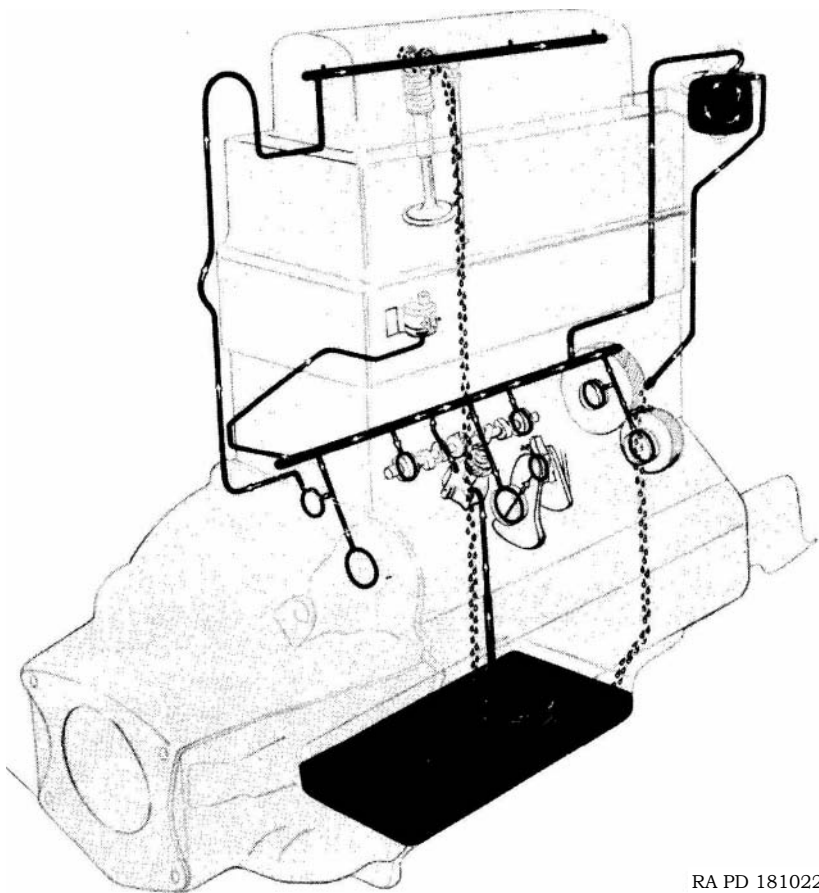

RA PD 181022

Figure 11. Engine lubrication system.

f. The intake valve mechanism and rocker arm shaft parts are also lubricated by the engine lubrication system. They receive lubrication through an external oil line which conducts the oil from the oil gallery in the cylinder block to an oil passage in the cylinder head. A drilled hole in the center of the rocker arm shaft support mates with the oil passage in the cylinder head to form the path through which oil is forced to the hollow rocker arm shaft. The oil fills the rocker arm shaft and is fed to each of the rocker arms through holes provided in the rocker arm shaft. The returning oil drains from the cylinder head to its lowest part and finally to the oil pan through the intake valve push rod openings.

g. The pressure under which the oil is supplied to the bearings and other parts of the engine, is controlled by a pressure regulator or relief valve located in the side of the oil pump. The valve is set to maintain a pressure of 30 to 35 spi at a vehicle speed of approximately

30 mph. At idling engine speed pressure is approximately 10 psi with clean warm oil.

h. An oil filter is included in the lubrication system to maintain the oil free from sludge, etc., between oil changes. A combination oil filler pipe can and bayonet type gage, installed in the oil filler pipe, provides the means for determining the oil level.

23. Tabulated Data

Engine :

Type	F-Head
Number of cylinders	4
Bore	3 $\frac{1}{4}$ in.
Stroke	4 $\frac{1}{2}$ in.
Piston displacement	134. cu. in.
Compression ratio	7.4 to 1
Compression	135 psi at 185 rpm
Horsepower—SAE	15.63
Maximum torque	114 lb-ft at 2000 rpm
Firing order	1-3-4-2

Section II. CLEANING, INSPECTION, AND REPAIR PROCEDURES

24. General

Because of the obvious impossibility of describing in detail all of the various kinds of wear or damage or conditions of dirt, fouling, or foreign material deposits that might be discovered in the operation of rebuilding the engine, the cleaning inspection and repair paragraphs in this publication are limited to the description of the normal or common operations. Except in the cases where these specific procedures are given, the mechanic is expected to exercise his good judgment or to consult a higher authority when or if unusual conditions or difficulties are encountered during the performance of the cleaning, inspection, and repair operations.

25. Cleaning Procedures

a. Cleanliness of personnel, tools, and surroundings is a fundamental requirement where repair operations of a mechanical nature are carried on. This is particularly true of areas where engines are to be repaired or rebuilt. All of the information and instructions contained in this publication are given on the assumption that these conditions prevail in the working area. Engine repairs, except for those of an emergency nature, should never be attempted under any other conditions.

b. Use dry-cleaning solvent, volatile mineral spirits, or high pressure steam, whichever is available, for all cleaning operations. Use compressed air to dry the parts.

c. When preparing to rebuild or repair an engine assembly, scrape or wire brush all accumulations of dirt or road mud from external surface of the assembly. Note and mark, by scratching the metal parts with a sharp pointed tool, any moist oil spots or unusually heavy accumulations of oil-soaked road mud, for they are good clues to the location of small cracks or holes which might escape notice in a visual inspection. Do not, however, confuse these accumulations with those that result from leaking gaskets or oil seals.

d. After marking any questionable areas for later and more thorough inspection, complete the external cleaning operation with steam cleaning equipment or by hand brushing, using volatile mineral spirits as a cleaning agent. Total immersion in a dip tank is also approved, provided the cleaning agent is dry-cleaning solvent or volatile mineral spirits.

26. Cleaning Component Parts After Disassembly

a. If other approved facilities are not available, all parts must be cleaned by hand using bristle brushes having the correct shape and of the proper size for the job to be done ; e., round brushes for internal bores; square or rectangular hand brushes for flat or external surfaces. Scrub each individual part except ball or roller bearings.

Note. Bearings require special handling. Refer to TM 37-,265 or TB ORD 438, and clean, inspect, and prepare for use all ball and roller bearings used in these assemblies according to the instructions given therein.

b. Clean all parts of hardened oil, lacquer deposits, and carbon. Wire brushes, either hand wielded or power driven, may be used for this purpose provided there is no possibility of damaging finished surfaces. Otherwise, the parts must be permitted to soak in solvent until the foreign material is loosened.

c. Remove all gaskets or parts of gaskets from gasket surfaces, using a putty knife or other suitable scraper. Be careful to avoid scratching or gouging the surface metal.

d. Rinse or flush the parts in clean dry-cleaning solvent or volatile mineral spirits. Even though the dirt or foreign matter is loosened by the cleaning action, it must be completely washed away by flushing. This is a mandatory operation on parts that have undergone repair operations which required them to be ground, honed, or lapped. Use solvent under pressure to force-flush repaired parts. In the absence of such facilities, however, the parts may be rinsed by immersing them in a container of clean dry-cleaning solvent or volatile mineral spirits and then sloshing them about vigorously either manually or by some improvised mechanical means. Dry the parts with compressed air blasts.

27. Inspection Procedures

a. All parts, regardless of their application or use, must be thoroughly examined and inspected to determine whether they are to be used or scrapped. The wear or damage of some parts will be evident to the eye, whereas in others it may be necessary to use tools or gages to determine the extent of wear.

b. When inspecting parts, bear in mind that the inspection procedure has two purposes. The first, to weed out any part or parts which are unsuitable for use, or doubtful parts which could conceivably cause the premature failure of the rebuilt unit. The second, and equally important purpose, is to reduce the wasteful and frequently unnecessary practice of scrapping parts which still retain a high percentage of their useful life. Consult the repair and rebuild standards (pars. 135-140) for limits of wear.

c. Instructions for the performance of minor repair operations or for the removal of minor imperfections and faults are given in the inspection paragraphs wherever they facilitate the inspection procedure. Every part on which even a minor repair is made must be washed, rinsed, and dried upon completion of the repair.

28. Repair Procedures

a. Only good workmanlike repairs are acceptable. Makeshift or temporary repairs are not permitted, except in extreme emergencies.

b. The principal purpose of repairs is to salvage parts which would otherwise be scrapped. The decision as to whether a part is to be repaired or not rests upon three factors. The first, is the practicality of the repair, that is, can the part be repaired and be thus returned to a like-new condition. If not, the repair should not be attempted. The second, is the cost of the repair as compared to the cost of a replacement part. If the cost factor does not favor the repair, the part should be discarded. The third, is the availability of replacement parts. If service parts are unavailable, or in short supply, every effort should be made to salvage as many parts as is possible, disregarding any of the other governing factors.

c. Upon completion of any repairs, clean and flush the parts as instructed in paragraph 26d.

29. Handling After Inspection and Repair

a. All parts, whether new or used, must be lightly coated with preservative lubricating oil, medium grade, immediately after inspection and/or repair, and prior to their assembly into the engine. Oiling the parts gives them a necessary rust preventive coating and facilitates the assembly operations.

b. Make sure that all new gaskets and replacement parts are available to replace those scrapped.

c. Check to see that all parts are at hand so that the assembly operations may go forward without interruptions.

d. Prepare new oil seals for assembly into the engine by placing them in a container filled with No. 10 engine oil. Allow the seals to soak for 45 minutes before installing.

Section III. DISASSEMBLY OF ENGINE INTO SUBASSEMBLIES

30. General

a. A complete rebuild of the engine requires that the entire engine assembly be disassembled into its individual parts. Before beginning the actual disassembly of the engine, however, the accessory assemblies furnished as part of the engine assembly must be first removed. In figures 3, 4, 5, and 6, these accessory assemblies are shown in their assembled positions. Figures 12 and 13 show the accessory assemblies and their attaching parts and fittings disassembled from the engine.

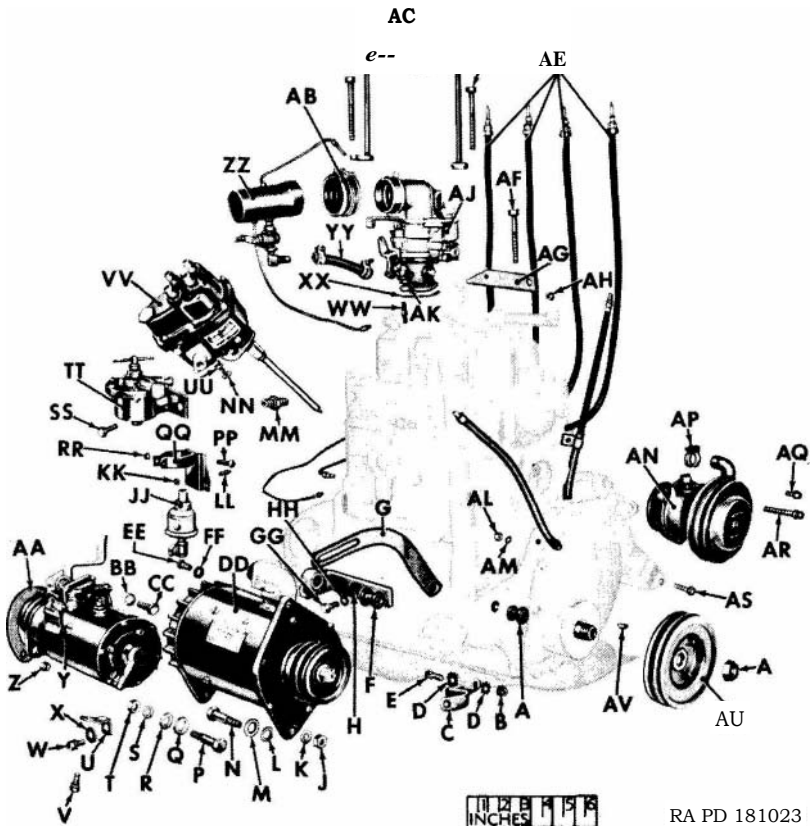

Figure 12. Engine accessory assemblies and mounting parts, brackets and fittings

- A—Insulator, brace-7375175
 B—Nut, lockwasher, $\frac{3}{8}$ -24NF-2—8328482
 C—Strap, ground-7371311
 D—Washer, lock, int-ext-teeth, % IN-178551
 E—Bolt, $\frac{3}{8}$ -24NF-3 x 1-181637
 F—Insulator, brace-7375175
 G—Brace, adjusting, belt tension-7375388
 H—Support, generator mounting-7375389
 J—Nut, %-16 NC-2-134566
 K—Washer, lock, $\frac{3}{8}$ -inch—120382
 L—Washer, plain, $\frac{1}{2}$ ID-120395
 M—Washer, plain, $\frac{17}{32}$ ID-120396
 N—Bolt, generator—WO-633949
 P—Bolt, generator—WO-633949
 Q—Washer, plain, $\frac{1}{2}$ ID-120396
 R—Washer, plain, $\frac{1}{2}$ ID-120395
 S—Washer, lock, %-inch-120382
 T—Nut, $\frac{3}{8}$ -16NC-2—134566
 U—Support, starter-8328133
 V—Screw, cap, lockwasher, $\frac{5}{16}$ -18NC-3 x %-451975
 W—Screw, cap, lockwasher, $\frac{3}{8}$ -16NC-2A x %-451976
 X—Washer, plain, $\frac{3}{8}$ -inch—446363
 Y—Starter, assy-8328132
 Z—Nut, %-24NF-2-120369
 AA—Gasket, starter, assy—WO-804396
 BB—Washer, lock, $\frac{1}{2}$ -inch—120384
 CC—Screw, cap, $\frac{1}{2}$ -13NC-2 x 1 $\frac{1}{4}$ —120426
 DD—Generator, assy-7374750
 EE—Bolt, $\frac{3}{8}$ -16NC-2 x 1-423571
 FF—Washer, plain, %-inch-120394
 GG—Screw, cap, %-16NC-2 x $\frac{3}{8}$ —WO-633949
 HH—Washer, lock, %-inch-120382
 JJ—Unit, sending, oil pressure, assy-7728856
 KK—Nut, lockwasher, $\frac{1}{4}$ -28NC-2—8329685
 LL—Stud
 MM—Unit, sending, water temperature, assy-7389566
 NN—Washer, plain, 1/4-inch-120392
 PP—Bolt
 QQ—Support, sending unit, oil pressure-8329686
 RR—Nut
 SS—Bolt, $\frac{3}{16}$ -24NF-2 x %-120741
 TT—Filter, oil, assy—WO-802147
 UU—Screw, cap, $\frac{1}{4}$ -20NC-2 x 805772
 VV—Distributor, assy—WO-806329
 WW—Stud, $\frac{3}{8}$ -16NC-2 (%6) x $\frac{3}{8}$ -24NF-2 (%x) x 11%6-111318
 XX—Insulator, carburetor-8329828
 YY—Hose, vent—WO-806357
 ZZ—Pipe, air intake, assy—WO-809246
 AB—Hose, carburetor to air cleaner pipe-8329646
 AC—Hook, lifting-8328396
 AD—Screw, cap, $\frac{1}{16}$ -14NC-2 x 4%-8329678
 AE—Cable, spark plug, assy-8328449
 AF—Screw, cap, $\frac{5}{16}$ -14NC-2 x 4 $\frac{1}{4}$
 AG—Bracket, mounting, oil filter—8328422
 AH—Nut, lockwasher, $\frac{5}{16}$ -24NF-2—804976
 AJ—Carburetor, assy-8329774
 AK—Nut, %-24NF-2-120369
 AL—Nut, %-24NF-2-120369
 AM—Washer, lock, %-inch-120382
 AN—Pump, water, assy-7372806
 AP—Clamp, hose, 1-inch-502913
 AQ—Screw, cap, lockwasher, $\frac{3}{8}$ -18NC-2 x 7A-7372812
 AR—Screw, cap, lockwasher, $\frac{5}{16}$ -8NC-2 x 21/2-7372813
 AS—Bolt, adjusting brace—WO-A1468
 AT—Nut, 1%6-inch-7697864
 AU—Pulley, fan and generator drive-7372558
 AV—Key, woodruff, $\frac{3}{16}$ x %-124549

Figure 12.—Continued

Instructions for removing these accessories are furnished in TM 9-804A and therefore are not repeated herein. When preparing to remove the accessory assemblies, set the engine assembly upright on a suitable stand or work bench, blocking it securely to prevent damage to the assembly or injury to personnel.

b. Remove accessories from the engine according to the instructions furnished in TM 9-804A. During removal of the accessories, disconnect and remove the connecting fuel, vacuum, oil, and vent lines as instructed in paragraph 31k. Accessories to be removed are as follows :

- | | |
|-------------------------------|---------------------------|
| Carburetor | Oil pressure Sending Unit |
| Distributor | Water Pump |
| Generator | Fuel Pump |
| Starter | Spark Plugs |
| Oil Filter | Clutch |
| Fan and Generator Drive Belts | |

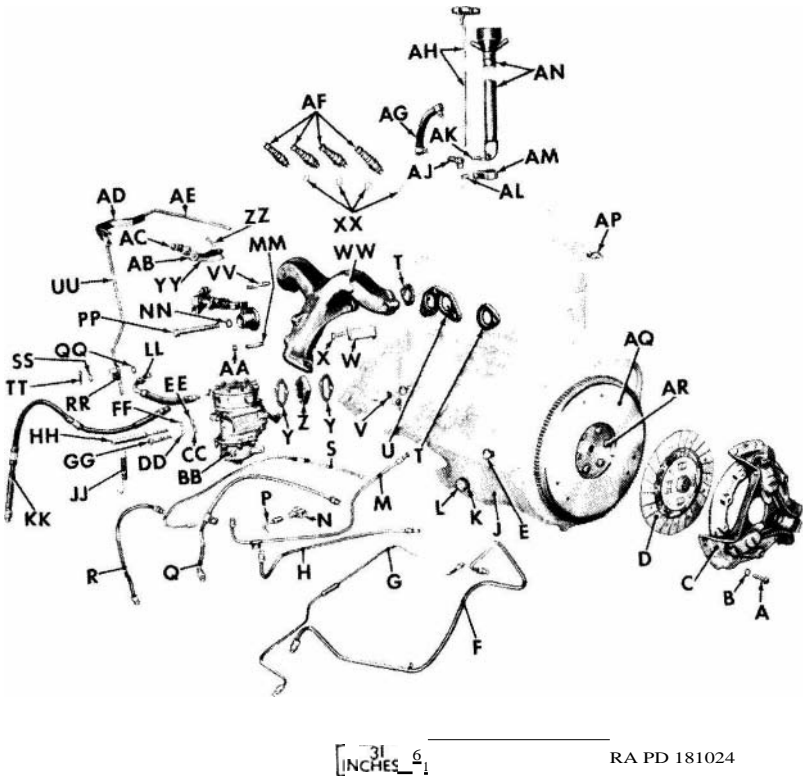

RA PD 181024

Figure 13. Engine accessory assemblies and mounting parts, brackets, and fittings—left rear view.

- A—Screw, cap, $\frac{1}{4}$ -18NC-2 x $1\frac{1}{16}$ —7324841
- B—Washer, lock, $\frac{5}{16}$ -inch—120638
- C—Clutch, with cover, assy-120638
- D—Disk, driven, clutch-8328127
- E—Elbow, 90 deg, 14-inch-137421
- F—Line, fuel pump to carburetor—WO-806065
- G—Line, oil pressure—WO-807700
- H—Line, oil, sending unit, assy-8328407
- J—Pan, oil, assy-7371278
- K—Gasket, oil pan drain plug—WO-639979
- L—Plug, drain, oil pan, $\frac{7}{8}$ -inch—WO-639979
- M—Line, vent—WO-807846
- N—Tee, inv flared tube, $\frac{1}{4}$ -inch—178910
- P—Line, tee to windshield wiper—WO-807845
- Q—Line, vent, crankcase-806359
- R—Line, vent, metering valve to tee—WO-807846
- S—Line, distributor to windshield wiper fitting—WO-806420
- T—Gasket, end, exhaust manifold—WO-648795
- U—Gasket, center, exhaust manifold—WO-648935
- V—Elbow, 90 deg, $\frac{1}{8}$ -inch 111038
- W—Support, dual control—WO-806449
- X—Screw, cap, lockwasher, $\frac{3}{8}$ -16NC-2 x $\frac{1}{2}$ -7346875
- Y—Gasket, fuel pump—WO-638737
- Z—Spacer, fuel pump—WO-800361
- AA—Nut, self-locking, $\frac{3}{8}$ -24NF-3—503354
- BB—Pump, fuel, assy—WO-805727
- CC—Washer, rectangular, 0.406 ID—WO-805842
- DD—Washer, lock, $\frac{5}{16}$ -inch—120214
- EE—Washer, rectangular, 0.406 ID—WO-805842
- FF—Washer, lock, 5/16-inch-120214
- GG—Screw, cap, $\frac{1}{4}$ -18NC-2 x $1\frac{1}{8}$ —122058
- HH—Screw, fuel pump—WO-800741
- JJ—Spring, return, accelerator pedal—8329764
- KK—Line, flexible, oil filter inlet, assy-8328409
- LL—Line, flexible, fuel pump inlet—WO-806172
- MM—Stud, $\frac{3}{8}$ -16NC-2 x $\frac{1}{2}$ -24NF-3 x 11A-7372581
- NN—Gasket, ventilator body—WO-630299
- PP—Screw, cap, special—WO-645093
- QQ—Washer, plain, $\frac{5}{16}$ -in.—120393
- RR—Bellcrank, lower, accelerator—8329766
- SS—Washer, plain, $\frac{5}{16}$ -in.—120393
- TT—Pin, cotter, $\frac{1}{16}$ x $\frac{1}{2}$ -in.—112726
- UU—Rod, accelerator bellcrank link—8329765
- VV—Stud, $\frac{3}{8}$ -16NC-2 ($\frac{1}{2}$) x $\frac{3}{8}$ -24NF-3 ($\frac{1}{2}$) x 13/4-8329753
- WW—Manifold, exhaust-8329699
- XX—Gasket, annular, 14 MM-150189
- YY—Bracket, accelerator bellcrank—8329768
- ZZ—Pin, cotter, $\frac{1}{8}$ x 1/2-inch-112726
- AB—Washer, plain, 1%2 ID, 1/4 OD—120393
- AC—Spring, accelerator bellcrank—8329770
- AD—Bellcrank, upper, accelerator—WO-805478
- AE—Rod, throttle-8329763
- AF—Plug, spark, assy-8357724
- AG—Hose, vent—WO-807400
- AH—Gage, oil level, assy-8328406
- AJ—Elbow, vent
- AK—Screw, cap, lockwasher, $\frac{1}{4}$ -18NC-2 x 11/4-423564
- AL—Spacer, oil filler pipe bracket—8329694
- AM—Bracket, support, oil filler pipe—7368276
- AN—Pipe, oil filler, assy—8329683
- A1'—Tee, $\frac{1}{4}$ -in.—444132
- AQ—Flywheel, assy—8328045
- AR—Nut, $\frac{3}{8}$ -24NF-2—120369

Figure 13.—Continued

31. Remove Accessory Mounting and Attaching Parts

After removing the accessories, use figures 12 and 13 as a guide, and remove the accessory attaching parts, brackets, and fittings as follows :

a. *Remove Engine Lifting Hook* (fig. 12). Remove the two cylinder head cap screws (AD) securing the engine lifting hook (AC) to the engine. Remove the hook.

b. *Remove Oil Filter Mounting Bracket* (fig. 12). Remove the cylinder head cap screw (AF) from the front end of the oil filter mounting bracket (AG) and remove bracket.

c. *Remove Oil Filler Pipe* (fig. 13). Lift the oil level gage (AH) out of the oil filler pipe (AN). Loosen the hose clamps (AP) and slide the vent hose (AG) off the rocker arm cover vent elbow (AJ). Remove the oil filler pipe support bracket cap screw (AK) and spacer (AL). Remove the oil filler pipe (AN) by grasping the top of the pipe and working it from side to side while pulling upward. Slide the oil filler pipe support bracket (AM) off the lower end of the pipe.

d. *Remove Starter Support* (fig. 12). Remove the starter support cap screw (W) and plain washer (X.). Remove the starter support (U).

e. *Remove Engine Ground Strap* (fig. 12). Remove the engine ground strap bolt (E), the internal-external-teeth lockwashers (D), and lockwasher nut (B), and remove the ground strap (C).

f. *Remove Generator Mounting Support* (fig. 12). Remove the generator mounting support cap screws (GG) and lockwashers (HH), and the generator mounting support (H). Remove the generator mounting support brace insulator (A) from the engine front mounting plate and the brace insulator (F) from the generator mounting support (H).

g. *Remove Belt Tension Adjusting Brace* (fig. 12). Remove the belt tension adjusting brace attaching nut (AL), lockwasher (AM), and bolt adjusting brace (AS). Remove the belt tension adjusting brace (G).

h. *Remove Oil Pressure Sending Unit Support* (fig. 12). Remove the oil pressure sending unit support stud lockwasher nuts (KK) and the support (QQ). Remove the studs (LL) from the cylinder block.

i. *Remove Exhaust Manifold* (fig. 13). Remove the exhaust manifold stud self-locking nuts (AA) and remove the exhaust manifold (WW) and exhaust manifold center and end gaskets (U and T).

j. *Remove Dual Control Support* (fig. 13). Remove the dual control support lockwasher cap screw (X) and the dual control support (W).

k. *Remove Vent, Vacuum, Oil, and Fuel Lines* (fig. 13).

(1) *Crankcase vent line (Q) (intake manifold to tee)*. Disconnect the fittings at the intake manifold tee and the inverted

flared tube tee (D, fig. 110) on the end of the metering valve (E, fig. 110) and remove the vent line by releasing the double clips (J, fig. 105) which secures it to the fuel pump to carburetor line (F).

- (2) *Vent line (M) (fuel pump to tee)*. Disconnect the fittings at the fuel pump (BB) and the inverted flared tube tee (N).
- (3) *Fuel pump to carburetor line (F)*. Disconnect the line fittings at the fuel pump (BB) and the carburetor (AJ, fig. 12) and remove the line.
- (4) *Distributor to windshield wiper fitting line (S)*. Disconnect the line fittings at the distributor (VV, fig. 12) and the connector installed in the tee inverted flared tube (N) and remove the lockwasher cap screw (A, fig. 5) which secures the line clip to the rear of the cylinder block. Remove the line and the tee (N) and disconnect the windshield wiper line (P) from the tee.
- (5) *Pressure oil line (G) (fuel pump to flywheel housing)*. Disconnect the line fitting at the fuel pump (BB). Remove the line by releasing it from the snap clip welded to the exhaust valve spring compartment cover.
- (6) *Sending unit oil line (H) (cylinder block elbow to oil pressure sending unit)*. Disconnect the fittings at the elbow (E) and the oil pressure sending unit (JJ, fig. 12) and remove the line. Remove the elbow (E) from the cylinder block.
- (7) *Oil filter inlet flexible line (K If) (cylinder block elbow to oil filter)*. Disconnect the hose fittings at the elbow (V) and at the oil filter (TT, fig. 12). Remove the two clips (C, fig. 97) from under the heads of the bolts at the water pump and at the timing gear cover and remove the line.
- (8) *Fuel pump inlet flexible line (LL) (fuel and vacuum pump to fuel tank line)*. Disconnect the line fitting at the fuel pump (BB) and remove the line.
- (9) *Vent line (M) (fuel pump to tee)*. Disconnect the line fittings at the inverted flared tube tee (D, fig. 110) and fuel pump (BB) and remove the line.

1. Remove Throttle Linkage (fig. 13).

- (1) Disconnect the accelerator pedal return spring (JJ) from the drilled hole in the head of the oil gallery hole plug and from the accelerator lower **bellercrank** (RR).
- (2) Remove the cotter pin (TT) and plain washer (SS) from the end of the exhaust valve spring compartment cover stud. Remove the cotter pin (ZZ) and plain washer (AB) from the end of the shaft on the accelerator upper **bellercrank** (AD) and slide the upper **bellercrank** out of the hole in the upper accelerator **bellercrank** bracket (YY) and the accelerator lower

bellcrank (RR) off the exhaust valve spring compartment cover stud. Remove the accelerator bellcrank spring (AC) from the upper bellcrank shaft.

- (3) Complete the disassembly of the accelerator linkage parts by removing the cotter pins from the ends of the accelerator bellcrank link rod (UU).
- (4) Remove the cylinder head cap screw, which secures the upper accelerator bellcrank bracket (YY) to the cylinder head, and remove the bellcrank bracket.

m. Remove Ventilation Valves and Related Parts (fig. 13). Remove the cap screw (PP) and ventilator body gasket (NN) securing the crankcase vent body and related parts (fig. 115) to the exhaust valve spring compartment cover and to the cylinder block. Remove the crankcase vent body and the engine ventilation system parts threaded to it. Refer to paragraph 138 for disassembly instructions for these parts.

32. Remove Rocker Arm Assemblies and Related Parts

Note. At this point in the disassembly operation, the engine should be mounted in a suitable engine repair stand. Where practicable, modify or adapt existing base shop repair stands as necessary to accommodate the engine. If engine repair stands are unavailable, take care to perform the following operations in a manner designed to protect personnel against harm and the engine and its parts against damage.

a. Remove the oil pan drain plug and gasket (K and L, fig. 13) and drain the oil pan. Remove the two nuts (V, fig. 70) from the rocker arm cover studs (fig. 14). From the front stud, remove three spark plug cable clips (U, fig. 70) and the copper rocker arm cover stud gasket (T, fig. 70). From the rear stud remove one spark plug cable clip and the copper gasket. Remove the rocker arm cover (S, fig. 70) and rocker arm cover gasket (X, fig. 70).

b. Unscrew and remove the two rocker arm cover studs (fig. 14) from the rocker arm shaft brackets at either end of the rocker arm assembly. Invert the studs and install them in the same openings, screwing them down to a snug fit. Remove the nuts from the rocker arm shaft bracket studs, and lift the rocker arm assembly up and off the studs. Lift the intake valve push rods out of the cylinder block.

Note. The studs are installed inverted to enable the rocker arm assemblies and their related parts to be removed as one unit. The studs must be installed to keep the rocker arm shaft springs from expanding and causing the end pieces to be pushed off the rocker shaft when the assembly is removed from the cylinder head. To avoid any possibility of the end of the stud damaging the rocker arm shaft, install the studs just tight enough to bind the brackets to the shaft.

33. Remove Cylinder Head

a. Remove the crankcase to cylinder head oil line (D, fig. 5) by disconnectin^g the line fittin^gs from the inverted flared tube connector

(fig. 15) in the cylinder head and from the elbow in the lower section of the cylinder block.

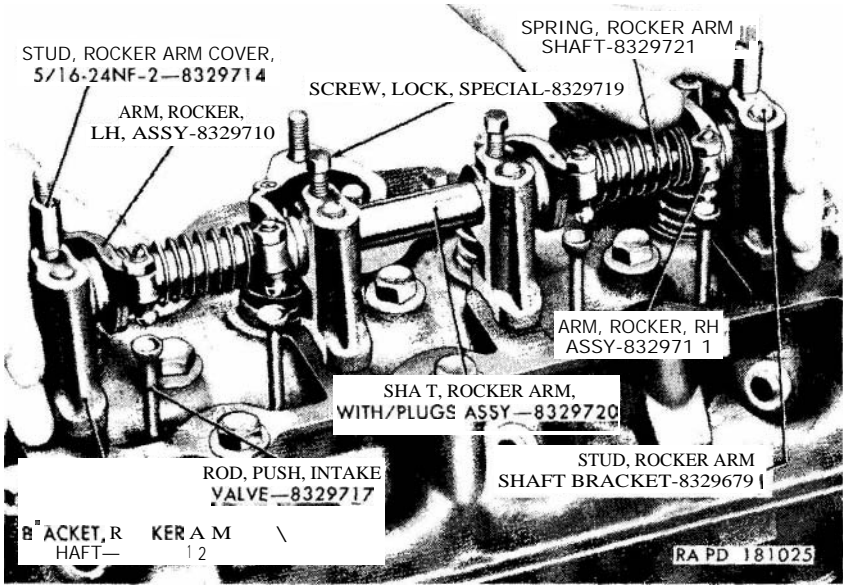

Figure 14. Removing rocker arm assemblies and related parts.

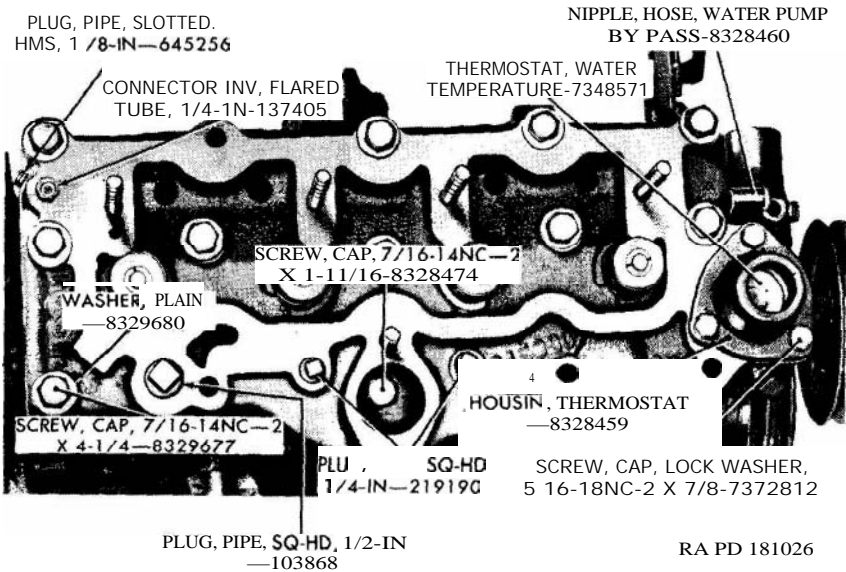

Figure 15. Top view of cylinder head.

b. Remove the remaining cylinder head cap screws and plain washers (fig. 15).

Caution: One cylinder head cap screw (fig. 15) is located inside the intake manifold and is removed by inserting a wrench into the carburetor opening in the cylinder head. Do not fail to remove this cap screw before attempting to remove the cylinder head. Remove the cylinder head and gasket.

34. Remove Fan and Generator Drive Pulley Shield and Oil Pan

Remove the six lockwasher cap screws which secure the fan and generator drive pulley shield (fig. 16) to the front underside of the engine, and remove the shield. Remove the fan and generator drive

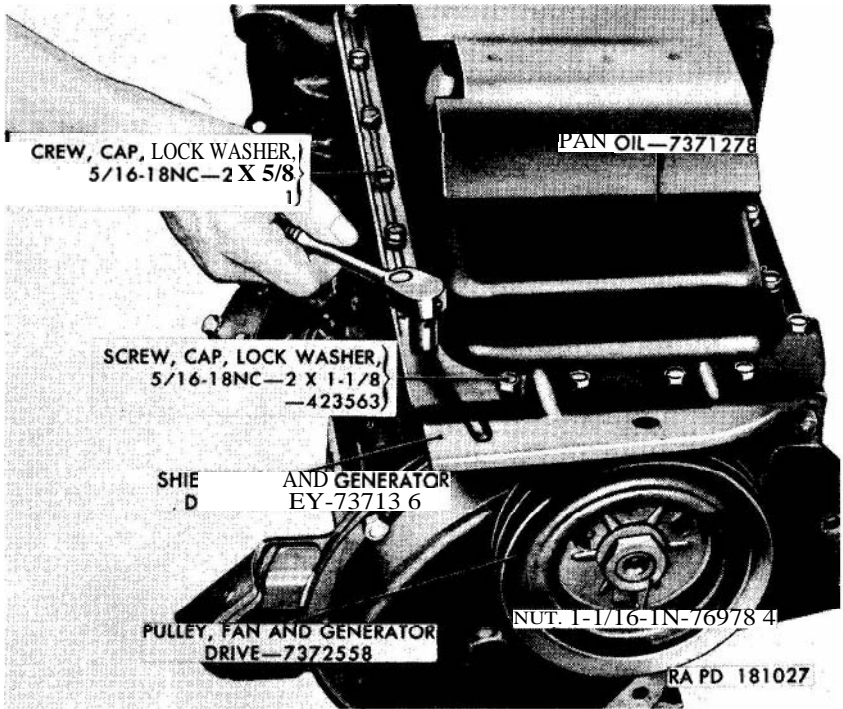

Figure 16. Removing fan and generator drive pulley shield.

pulley shield spacers and gaskets (fig. 17) and the remaining lockwasher cap screws which secure the oil pan to the cylinder block. Remove the oil pan.

35. Remove Oil Strainer

(fig. 18)

Remove the two lockwasher cap screws which secure the oil strainer to the bottom of the cylinder block. Remove the oil strainer.

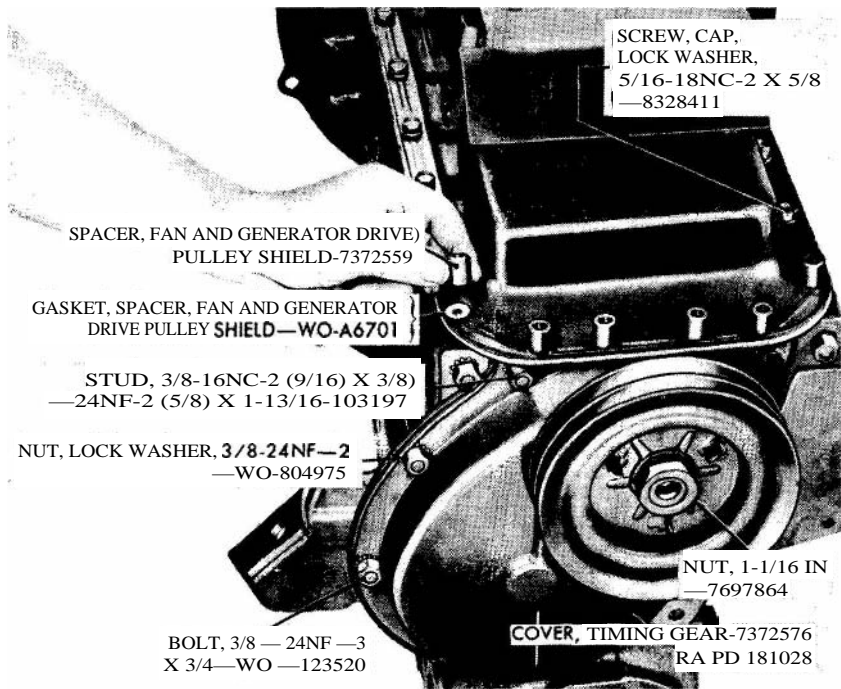

Figure 17. Location of fan and generator drive pulley shield spacers and gaskets.

36. Remove Fan and Generator Drive Pulley

(fig. 16)

Unscrew the nut which secures fan and generator drive pulley on the front end of the crankshaft. Using a standard remover, remove the fan and generator drive pulley.

37. Remove Timing Gear Cover

Remove the four bolts, lockwasher nuts and studs (fig. 17) securing the timing gear cover to the front end of the engine. Remove the cover, the fan and generator pulley woodruff key (AF, fig. 9), the crankshaft oil slinger (AC, fig. 9) and the crankshaft drive gear spacer (AB, fig. 9) from the front end of the crankshaft.

38. Remove Camshaft Driven Gear

Remove the cap screw (F, fig. 9) and the plain washer (E, fig. 9) securing the camshaft driven gear (J, fig. 9) on the front end of the camshaft. Using gear puller 41—P-2956-4 (fig. 19), pull the camshaft driven gear from the front end of the camshaft. Remove the camshaft gear woodruff key (AJ, fig. 9).

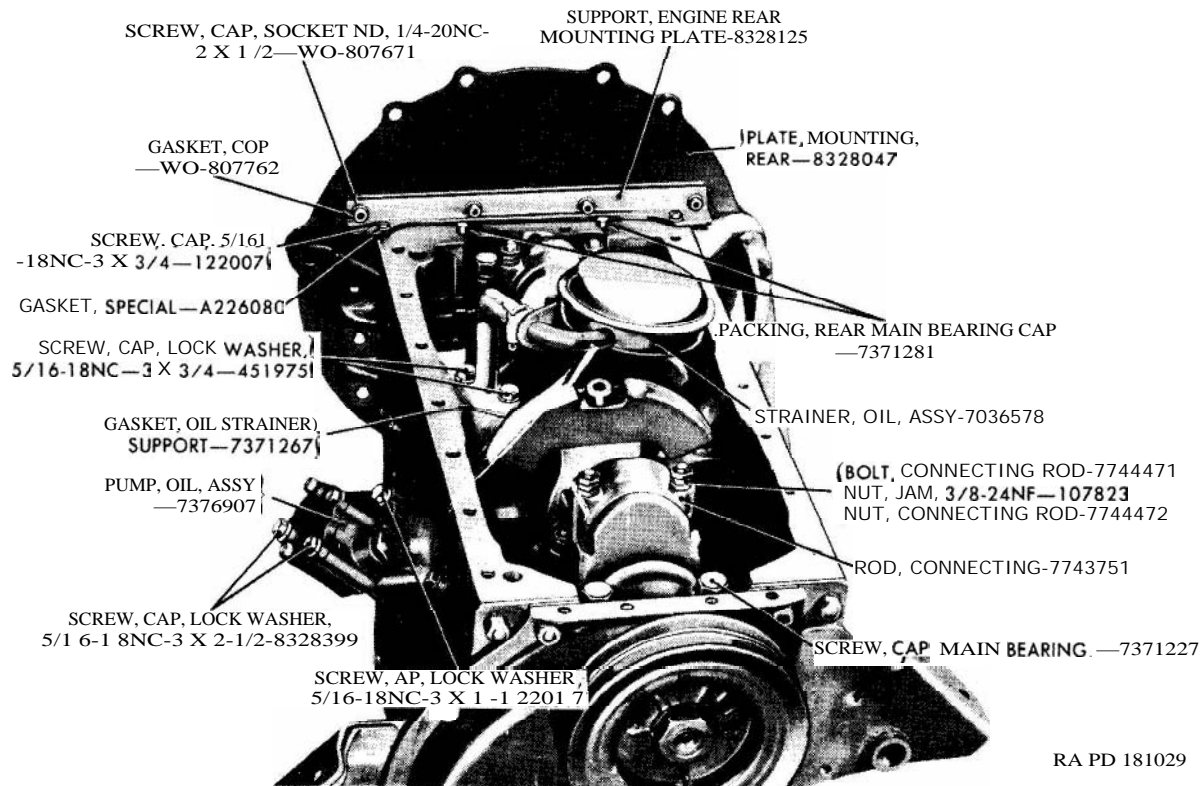

RA PD 181029

Figure 18. Bottom view of engine with oil pan removed.

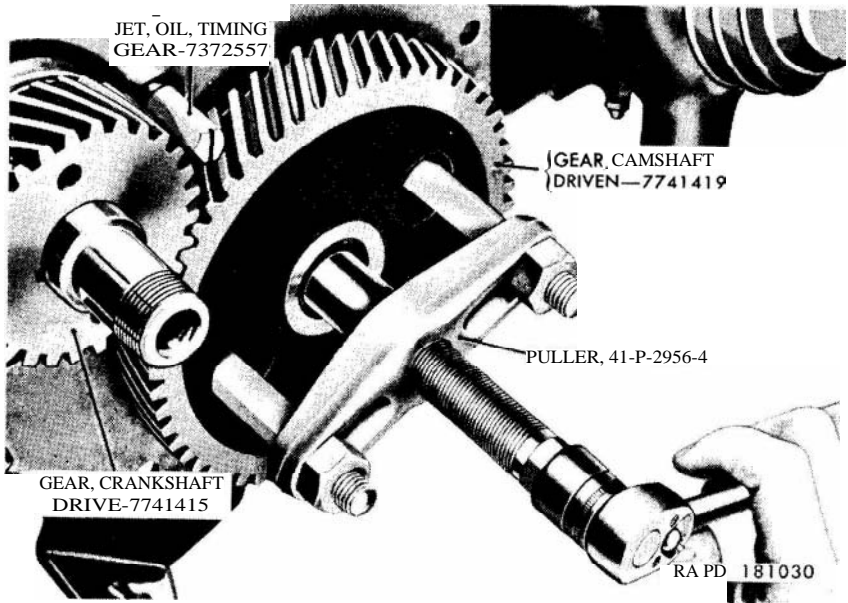

Figure 19. Removing camshaft driven gear.

39. Remove Crankshaft Drive Gear

Using gear puller 41-P--2956-4 (fig. 19), pull the crankshaft drive gear from the front end of the crankshaft. Remove the crankshaft drive gear woodruff key (AG, fig. 9). Unscrew and remove the timing gear oil jet (fig. 19) from the front end of the cylinder block.

40. Remove Front Mounting Plate and Front Mounting Support Cushions

Remove the nuts from the ends of the engine front mounting support cushion studs, located on each side of the front mounting plate (W, fig. 3), and remove the front mounting support cushions (B, fig. 3). Remove the four timing gear cover attaching studs (fig. 17) from the front end of the cylinder block. Remove the three lockwasher cap screws (fig. 78) and the two stud nuts which secure the front mounting plate to the front of the engine. Remove the plate. Remove the two studs.

41. Remove Flywheel Assembly

Remove the six nuts and lockwashers (AR, fig. 13) from the bolts securing the flywheel to the rear end of the crankshaft. Remove the flywheel (fig. 20).

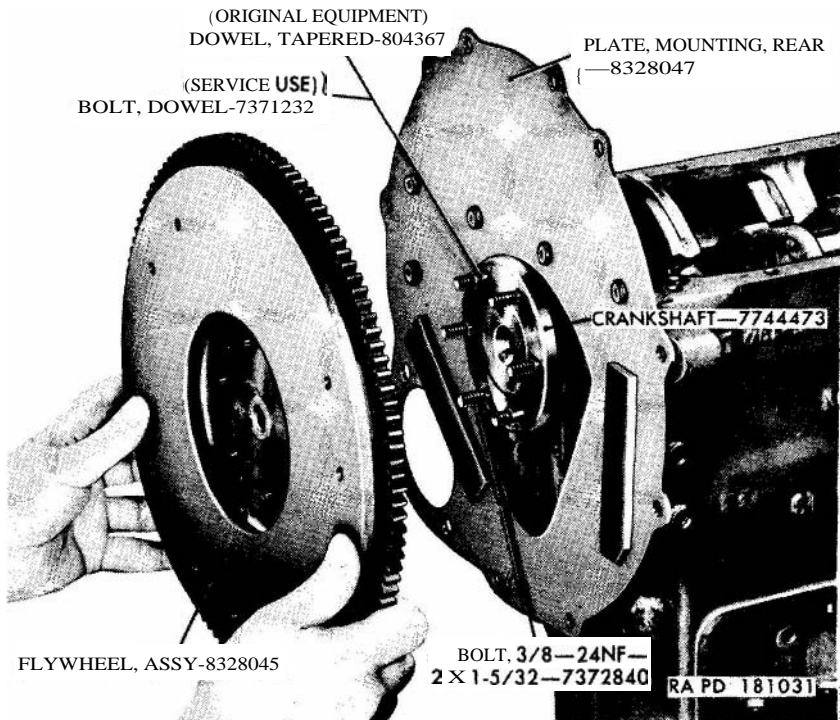

Figure 20. *Removing flywheel.*

42. Remove Rear Mounting Plate

Remove the eight cap screws (figs. 21 and 22), three on each side, and two holding engine rear mounting plate support (fig. 18) to the rear end of the cylinder block. Remove the plate and gasket.

43. Remove Oil Pump Assembly

(fig. 18)

Remove the three oil pump lockwasher cap screws. Remove the oil pump assembly and the gasket. Note that two of the cap screws go through the body of the oil pump and into the cylinder block; whereas a single cap screw goes through the mounting flange of the oil pump and into the cylinder block.

44. Remove Exhaust Valve Spring Compartment Cover

Remove the exhaust valve spring compartment cover stud (S, fig. 71). Remove the exhaust valve compartment cover (P, fig. 10) and the valve spring compartment cover gasket (D, fig. 71).

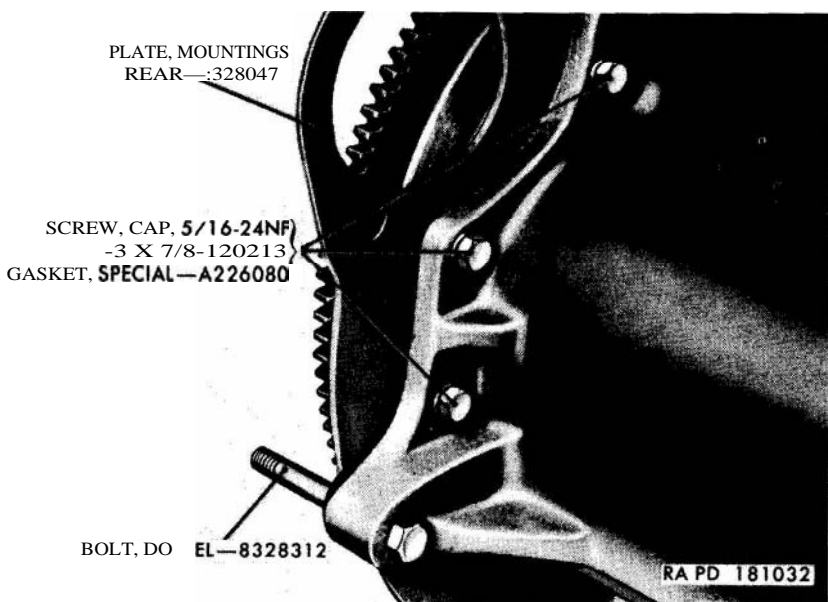

Figure 21. Location of rear mounting plate cap screws—right side of engine.



Figure 22. Location of rear mounting plate cap screws—left side of engine.

45. Remove Exhaust Valves

(fig. 23)

Using a valve spring compressing tool, lift the springs on those valves which are in the closed position (valve seated against cylinder block) and remove the exhaust valve rotator cap, the exhaust valve

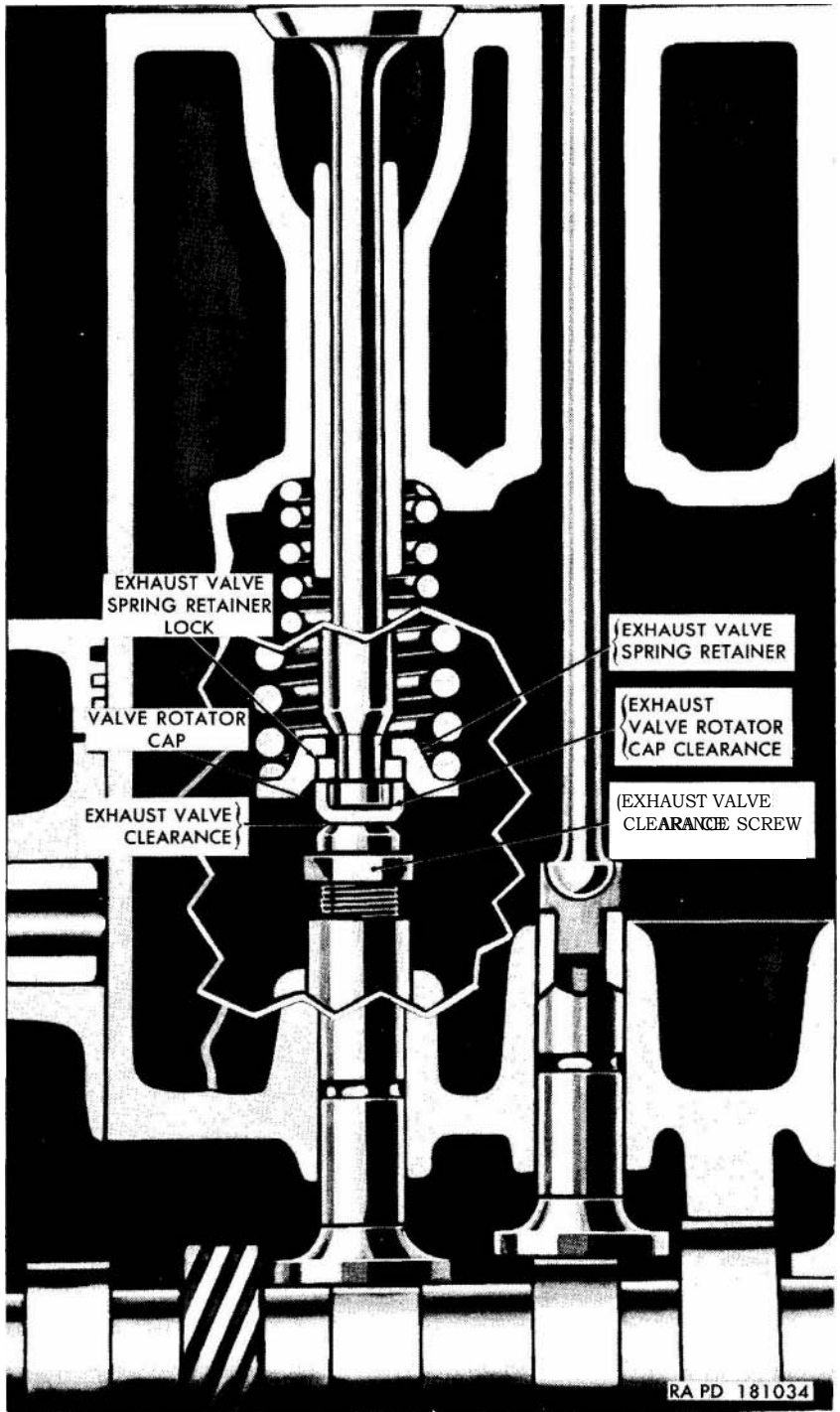

Figure 23. Exhaust valve and related parts—sectional view.

spring retainer locks, the exhaust valve spring retainer, and the exhaust valve spring. Repeat the operation on each exhaust valve, turning the camshaft as necessary to bring the valves to the closed position before commencing the operation. Lift the exhaust valves out of the cylinder block.

46. Remove Camshaft

(fig. 24)

If the engine is mounted in a repair stand, and it can be rotated, turn the engine upside down. With the engine in this position pull

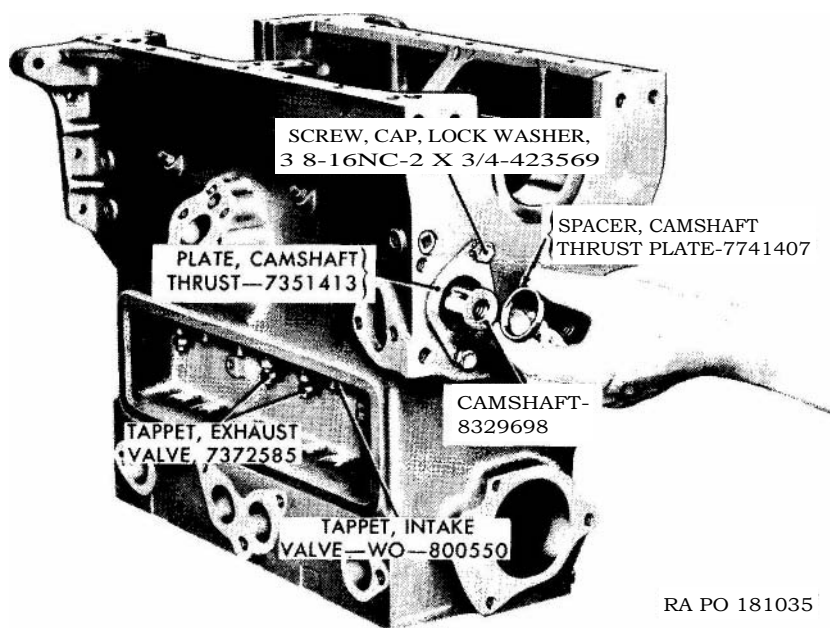

Figure 24. Removing camshaft thrust plate and spacer.

the intake and exhaust valve tappets down as far as possible so the ends of the tappets are not in contact with the camshaft.

Note. If the engine cannot be rotated, lift each tappet in turn, and secure the tappet in the raised position by installing a **COMMON** clip-type clothes pin on the shank of the tappet.

Remove the camshaft thrust plate spacer and camshaft thrust plate lockwasher cap screws. Remove the thrust plate, and pull the camshaft forward, out of the cylinder block, using care to prevent damage to the camshaft front bushing type bearing.

47. Remove Pistons and Connecting Rods

Remove the jam nuts (fig. 18) and hex nuts from the lower end of each connecting rod. Remove the cap of the connecting rod main

bearing and its half bearing (TT, *fig. 9*). Push the piston and connecting rod into the cylinder far enough to permit the half bearing to be removed from the connecting rod.

Note. The pistons and connecting rods may be removed at this time through the top of the cylinder block, or they may be allowed to remain in the cylinder block and removed through the bottom of the block after the crankshaft has been removed (par. 48). If the pistons and connecting rods are to be removed through the top of the block, use a cylinder ridge reamer to remove the ridge from the tops of the cylinder bores before removing the pistons. Wad cloth into the bores, on top of the pistons, to prevent the metal chips from becoming lodged between the piston and the cylinder walls.

After the pistons and connecting rods are removed from the engine, assemble the lower half of the connecting rod to the upper half so that these parts will remain together until they are assembled in the engine.

48. Remove Main Bearings and Oil Seal

(*fig. 25*)

Slide the crankshaft thrust washer and the end play adjusting shims off the front end of the crankshaft (*fig. 73*).

Note. There may be one or two shims, the actual number varying between engines.

Pull the two pieces of rear main bearing cap packing (*fig. 18*) up and out of their position between the bearing cap and the cylinder block. Remove the cap screws and lockwashers securing the main bearing caps to the cylinder block. Remove the bearing caps with the half main bearings in the caps and lift the crankshaft (B) out of the cylinder block. Remove the half main bearings from the bearing caps and the half main bearings from the cylinder block. Remove the bearing dowel pins (J), one each from the center and the rear main bearing caps (G and L), and one each from the front, center, and rear main bearing bores in the cylinder block. Remove the upper half of the rear main bearing oil seal (E) from the cylinder block and the lower half from the oil seal groove in the rear main bearing cap.

49. Remove Intake and Exhaust Valve Tappets

(*fig. 24*)

Remove the intake and exhaust valve tappets from the bottom of the cylinder block.

Section IV. REBUILD OF CYLINDER BLOCK ASSEMBLY

50. Disassembly

a. Remove the two pipe plugs (*fig. 26*) from the left outside surface of the cylinder block. Remove the two countersunk-head pipe plugs (*fig. 26*), one from each end of the block. Remove the slotted-headless pipe plug (*fig. 27*) from the cylinder block main oil gallery, and

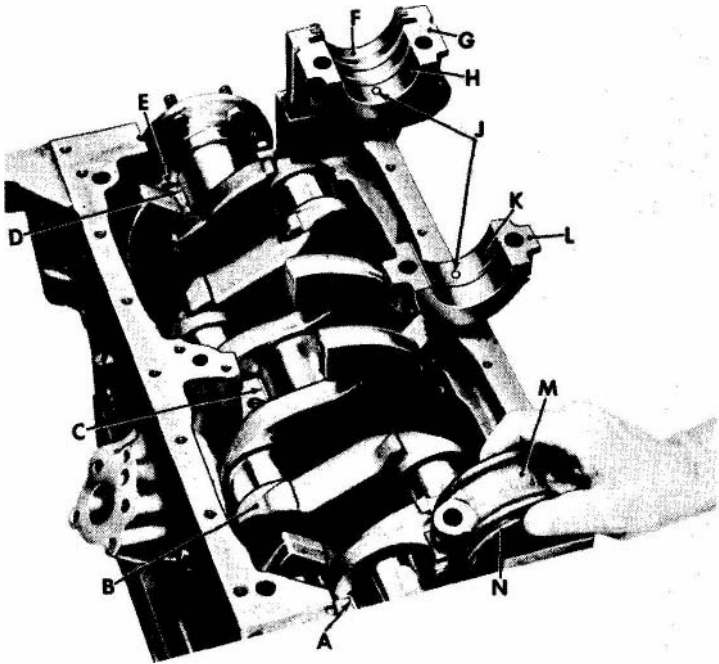

A—BEARING, HALF, FRONT, UPPER-
7371167
B—CRANKSHAFT—7744473
C—BEARING, HALF, CENTER, UPPER-
7371173
 D—BEARING, HALF, REAR, UPPER-
7371165
 E—SEAL, OIL, REAR BEARING
(UPPER HALF)—7372560
 F—SEAL, OIL, REAR BEARING
(LOWER HALF)—7372560
G—CAP, BEARING, REAR-
WO-737236

H—BEARING, HALF, REAR, LOWER-
7371169
J—PIN, DOWEL, BEARING-7371229
 K—BEARING, HALF, CENTER,
LOWER-7371225
 I.—CAP, BEARING, CENTER-
WO-630285
M—CAP, BEARING, FRONT—
WO-630285
 N—BEARING, HALF, FRONT, LOWER—
7371171

RA PD 181036

Figure 25. Removing main bearing caps and bearings.

the square-head pipe plug (fig. 27) from the tapped opening just below the oil pump intake passage inside the cylinder block.

b. Insert a 24-inch length of $\frac{1}{2}$ -inch bar stock into the camshaft bore in the cylinder block and drive against the bar to dislodge the expansion plug (fig. 27) from its seat in the rear end of the cylinder block.

c. Check the inside dimension of the front camshaft bushing type bearing (fig. 26). If the dimension does not exceed 2.1880 inch, the bearing need not be removed. If removal of the bearing is necessary, use the improvised camshaft front bearing remover and replacer (fig. 32) and drive the bearing out of the cylinder block.

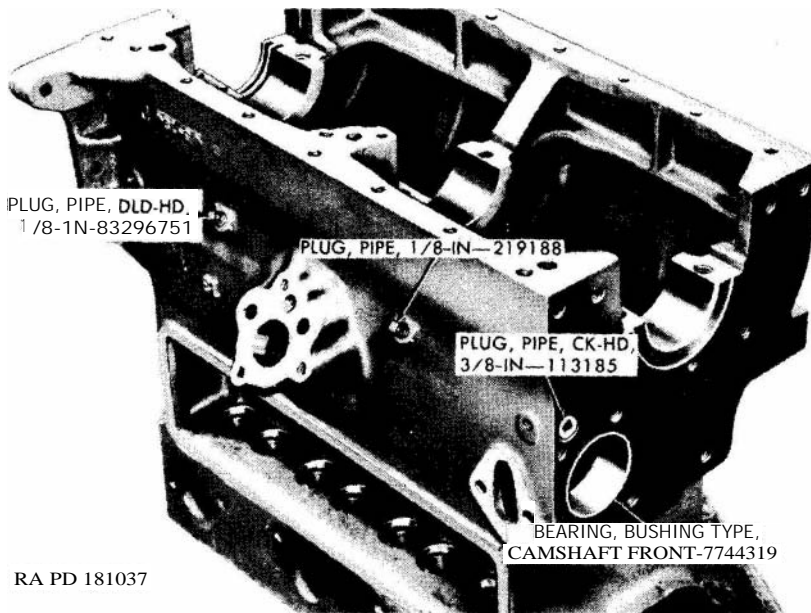

Figure 26. Location of oil gallery external hole plugs.

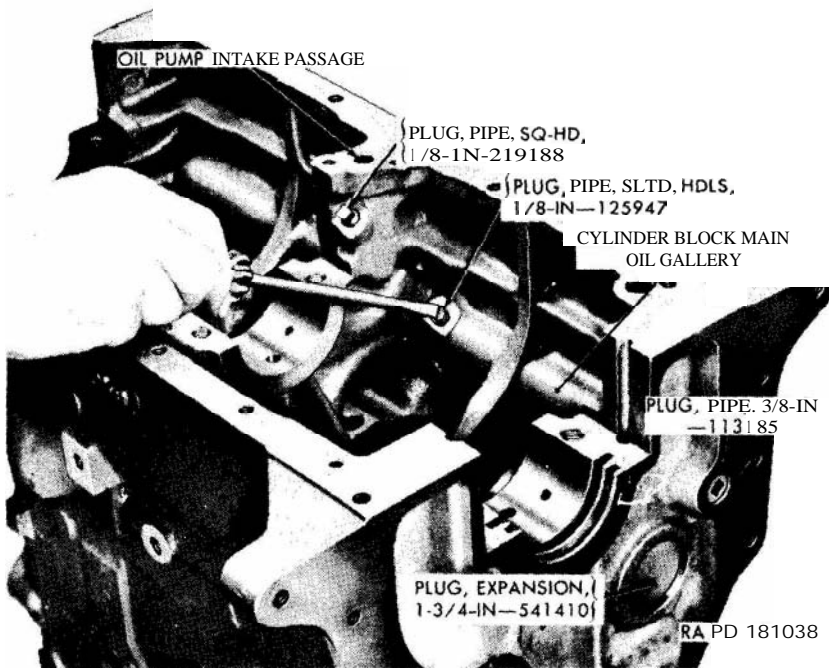

Figure 27. Location of oil gallery internal hole plugs.

d. Pierce the centers of the two expansion plugs (fig. 31) with a sharp chisel, and pry the plugs out of the cylinder block.

51. Cleaning, Inspection, and Repair

Note. Before performing the operations covered in this paragraph, refer to the general instructions given in paragraphs 24 through 29 relative to the cleaning, inspection, and repair of engine parts.

a. Cleaning.

- (1) Scrape and remove all accumulations of rust or foreign material from the water passages in the cylinder block.

Note. If the water passages are heavily coated with rust or clogged with foreign material, refer to TM 9-2858 for methods of removing these substances.

- (2) Clean the cylinder block main oil gallery (fig. 27) and the smaller oil passages in the cylinder block using round wire brushes slightly larger in diameter than the passages. Force flush the passages using cleaning fluid under pressure.

b. Inspection and Repair.

- (1) Inspect the top of the cylinder block for cracks or other damage which would make the block unfit for use. Check the tapped holes for rough or damaged threads and, if necessary, clean the threads by running the proper size tap into the holes. Remove any broken stud ends using a tool designed for this purpose.
- (2) Check the cylinder bores to see that none are scored, scratched or otherwise damaged so badly that the block is unfit for use. If the ridge was not previously removed from the top of the cylinder bores (par. 47) remove the ridge with a ridge reamer. Use extreme care not to undercut bore.
- (3) Check the dimensions of the cylinder bores with a cylinder bore gage. If the bores do not conform in all dimensions to those given in the repair and rebuild standards (par. 142a), they must be rebored to the next oversize.

Note: Pistons are furnished in standard, 0.020, 0.030, and 0.040 inch oversize.

- (4) If the cylinder bores are not worn beyond the dimensions given in the repair and rebuild standards, but the walls of the bores are glazed, use the finishing hone to remove the glaze.
- (5) Remove the exhaust valve guides using the driver only of valve guide remover and replacer 41-R-2379-25 (fig. 28) to drive the guides downward from the top of the cylinder block and into the exhaust valve spring compartment. Start the new valve guides, blunt (non-tapered) end first, into the valve guide bore in top of the cylinder block. Slide the

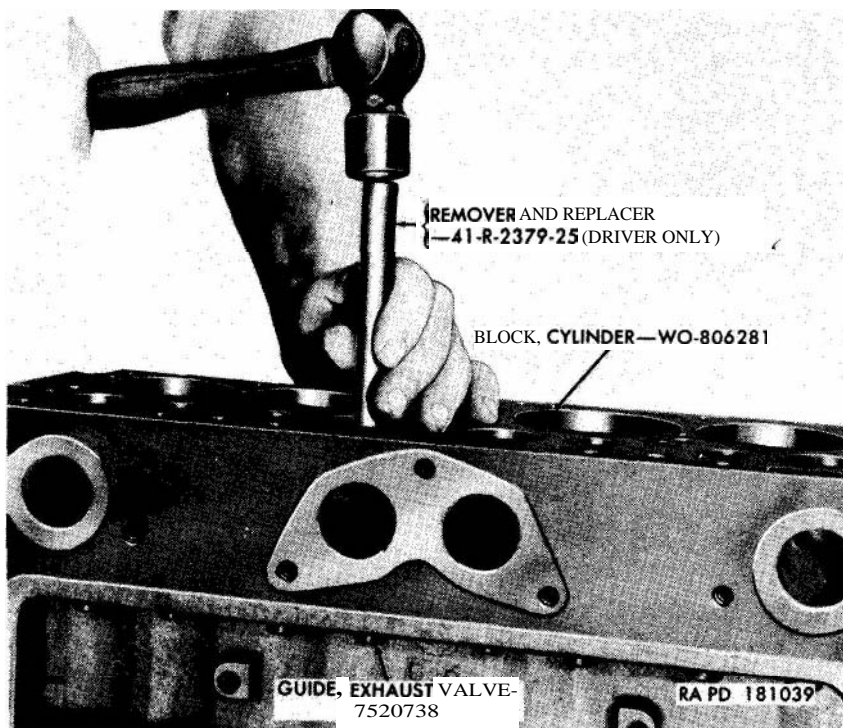

Figure 28. Removing exhaust valve guides using remover and replacer 41-R-2379-25.

- thicker of the two flat adapters of the remover and replacer 41-R-2379-25 onto the end of the driver and drive the guides into the block until the adapter seats against the top of the cylinder block. When properly positioned, the top (tapered) end of the guide is exactly 1 inch below the level of the top of the block (fig. 29). Run a $\frac{3}{8}$ -inch reamer (fig. 38) through the guides after they have been correctly positioned.
- (6) Use a valve seat grinding tool to grind the exhaust valve seats in the cylinder block just enough to true the seats and to remove pitted or burned areas. Maintain the width of the seats at three thirty-seconds of an inch and not wider than one-eighth of an inch. Upon completion of the valve seat grinding operation, check the valve seats for concentricity. Total, out-of-round of the valve seat, must not exceed 0.002 inch.
 - (7) Repair or replace the exhaust valves as instructed in paragraph 87, and then lap them to a perfect seat in the cylinder block exhaust valve seats.
 - (8) Force flush the exhaust valves and the cylinder block with cleaning fluid under pressure, or high **pressure** steam, to

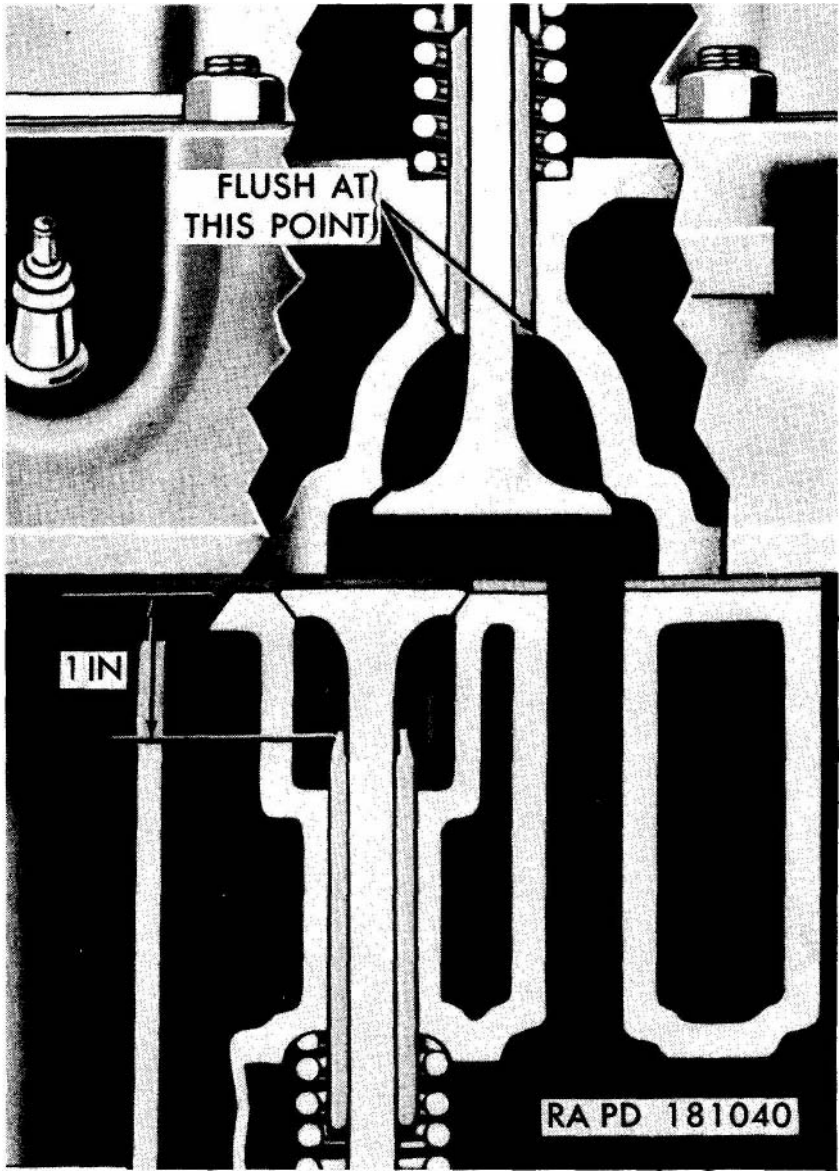

Figure 29. Intake **and** exhaust valve guides **installed**—**sectional** view.

remove all metallic particles resulting from the reboring, reaming, and grinding operations.

52. Assembly

(fig. 30)

a. Coat the sealing edges of the expansion plug recesses in the cylinder block with plastic type **gasket cement** and install the two

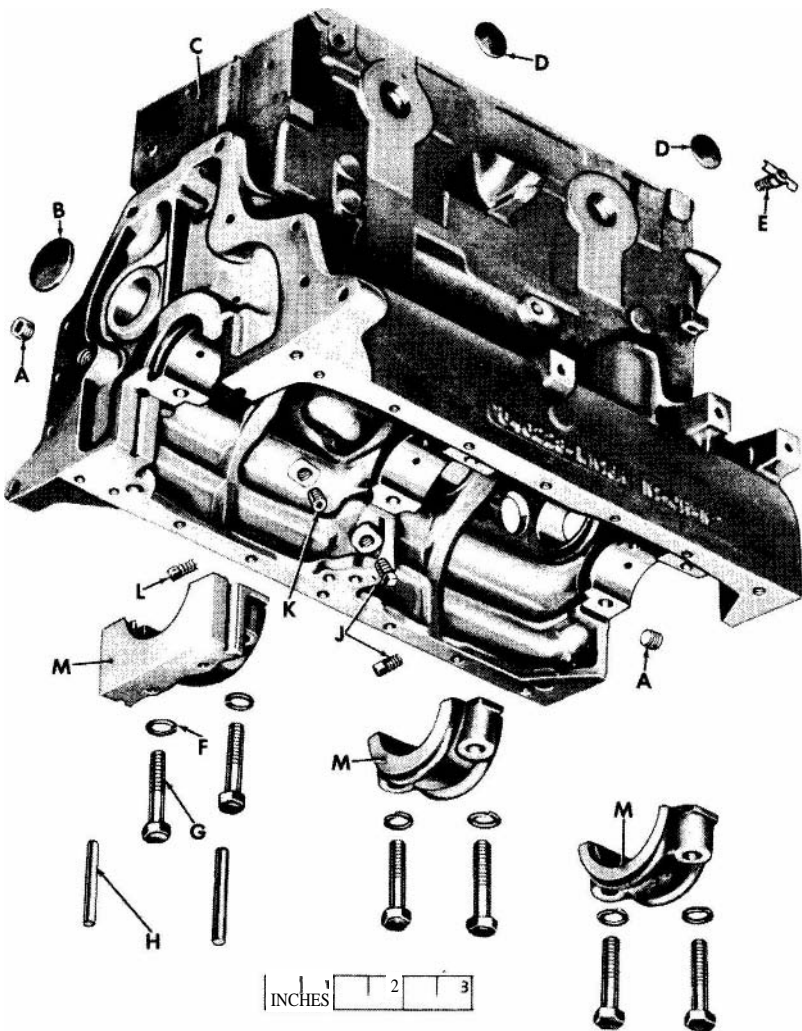

- A —PLUG, PIPE, CK-HD, 3/8-IN—113185
- B —PLUG, EXPANSION, 1.3/4-IN-541410
- C —BLOCK, CYLINDER, ASSY—WO-806281
- D —PLUG, EXPANSION, 1-1/4-IN—541402
- E —COCK, DRAIN, 1/4-IN—103647
- F —WASHER, LOCK, 1/2-IN—120384
- G —SCREW, CAP, SPECIAL-7371 227
- H —PACKING, REAR BEARING CAP-7371 281
- I —PLUG, PIPE, SQ-HD, 1/8-IN-219188
- K —PLUG, PIPE, SLTD HDLS, 1/8-IN—125947
- L —PLUG, PIPE, DLD, SQ-HD, 1/8-IN—8329675
- M —CAP, BEARING (PART OF CYLINDER BLOCK ASSY "C")

RA PD 181041

Figure 30. Cylinder block assembly—disassembled view.

1 1/4-inch expansion plugs (D) in the right side of the cylinder block and the one 1 3/4-inch expansion plug (B) in the camshaft bore in the rear end of the cylinder block. Use the improvised expansion plug seating tool to seat the plugs in the block (fig. 31).

Caution: Do not drive against the exact center of the plugs for a centered blow will cause the outer edges of the plugs to be deformed and the necessary perfect seal will not be made.

Install the 1/4-inch drain cock (E) in the lower center opening on the right side of the cylinder block.

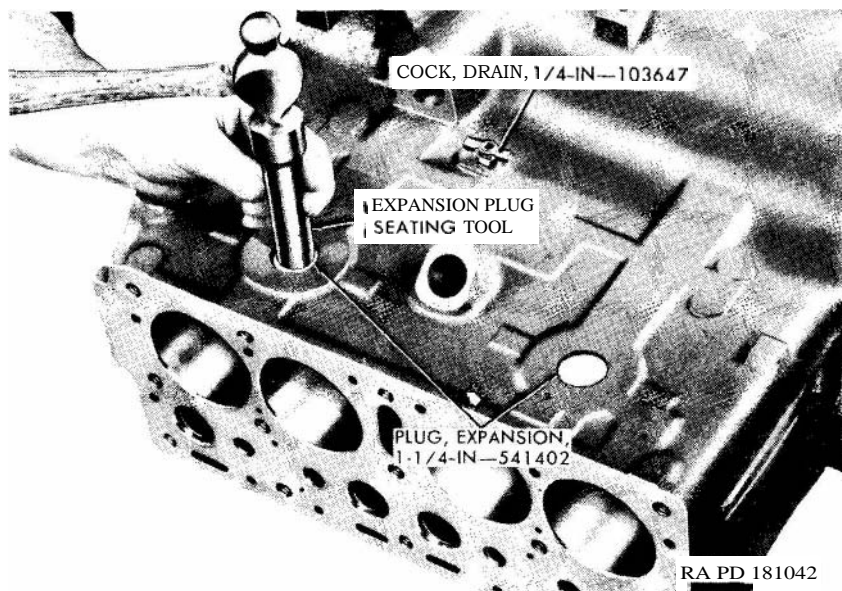

Figure 31. Installing expansion plugs.

b. Coat the threads with plastic type gasket cement and install the two 3/8-inch countersunk-head oil gallery pipe plugs (A), one in each end of the cylinder block (fig. 27). Install the two 1/8-inch square-head pipe plugs (L and J) in the openings in the oil passage on the left outside of the engine, making sure the plug with the drilled-head (L) is installed in the hole nearest the rear end of the engine (fig. 26).

c. Install the 1/8-inch slotter-headless pipe plug (K) in the opening in the main oil gallery inside the cylinder block (fig. 27). Install the 1/8-inch square-head pipe plug (J) in the opening in the oil passage directly below the oil pump intake passage.

Caution: Do not interchange these two plugs. If the plugs are interchanged, the counterweight of the crankshaft will strike the projecting head of the square-head plug.

d. If necessary, replace the camshaft front bushing type bearing (par. 50c), using the improvised camshaft front bearing remover and replacer (fig. 32). Slide the bearing onto the arbor of the remover and replacer, notched end first. Align the oil hole in the bearing with the oil hole in the bore in the cylinder block and drive the bearing into the bore until the front end of the bearing is flush with the front surface of the cylinder block.

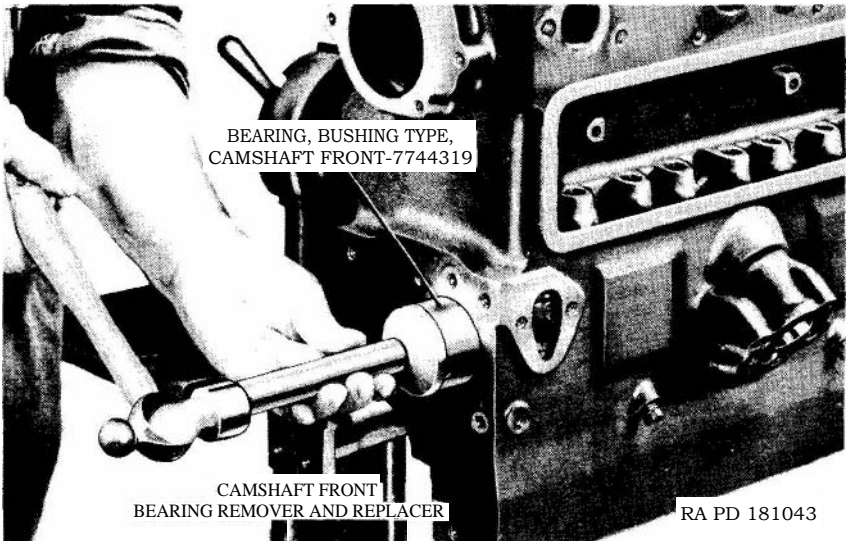

Figure 32. Installing camshaft front bearing.

e. Stake the bearing in place using an $\frac{11}{64}$ -inch drift punch inserted into the fuel pump opening in the side of the block and centered in the oil hole in the front camshaft bushing type bearing (fig. 33). Drive against the punch to cause the bearing metal to be driven into the oil hole in the cylinder block. Make sure the oil hole is open and clear after performing this operation. It is not necessary to line bore the bearing after installation.

Section V. REBUILD OF CYLINDER HEAD ASSEMBLY

53. Disassembly

a. Remove the three water temperature thermostat housing lock-washer cap screws (fig. 15). Remove the thermostat housing and the housing gasket. Remove the water temperature thermostat from the housing.

b. Unscrew and remove the water pump bypass hose nipple (fig. 15) from the cylinder head.

c. Unscrew and remove inverted flared tube connector (fig. 15).

d. Unscrew and remove the three square-head pipe plugs (fig. 15).

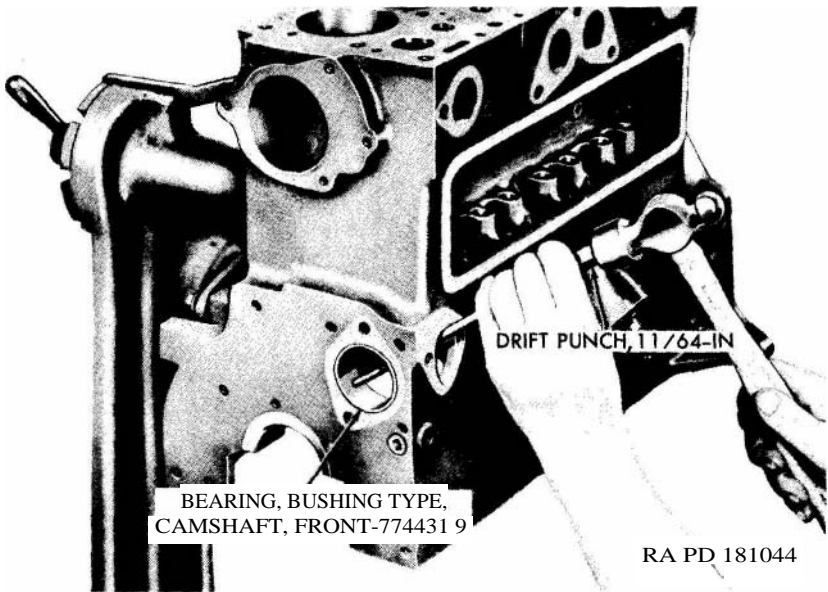

Figure 33. Staking camshaft front bearing.

e. Unscrew and remove the slotted-headless oil passage pipe plug (fig. 15).

f. Use a standard valve spring compressing tool (fig. 34) to compress the intake valve spring. While holding the valve spring compressed, remove the intake valve spring retainer locks and the intake valve spring retainer oil seal. Remove the valve spring compressing tool and lift the intake valve spring and the intake valve spring retainer up and off the valve stem. Remove the intake valve. Repeat the above procedure on all four intake valves.

Note. Do not remove the intake valve guides at this time. Refer to paragraph 54b(5).

g. Remove the four rocker arm shaft bracket studs (fig. 34).

54. Cleaning, Inspection, and Repair

Note. Before performing the operations covered in this paragraph, refer to the general instructions given in paragraphs 24 through 29 relative to the cleaning, inspection, and repair of engine parts.

a. *Cleaning.*

- (1) Scrape and clean all carbon deposits from the cylinder head and remove heavy accumulations of rust and foreign material from the water passages.

Note. If the cylinder head water passages are heavily coated with rust or clogged with foreign material, refer to TM 9-2858 for instructions on the procedures to follow to remove these deposits.

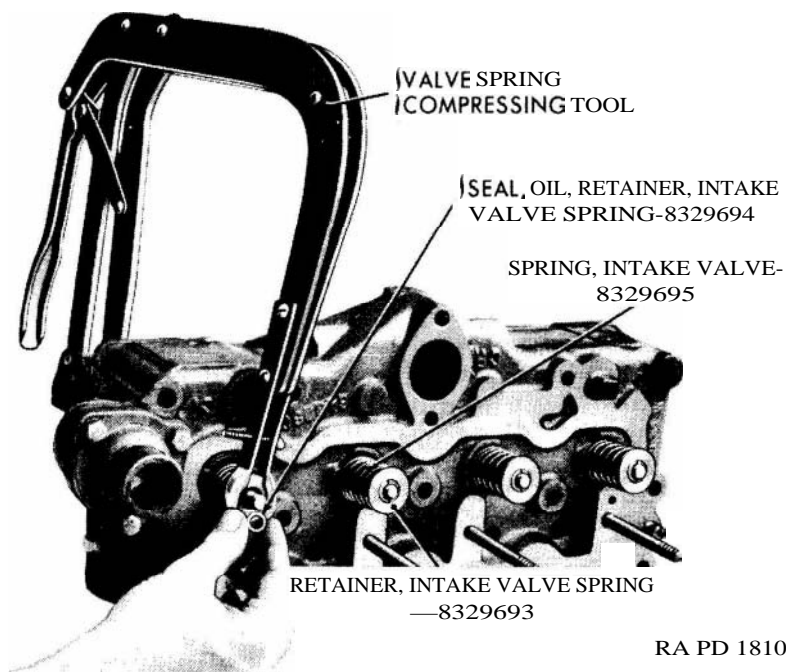
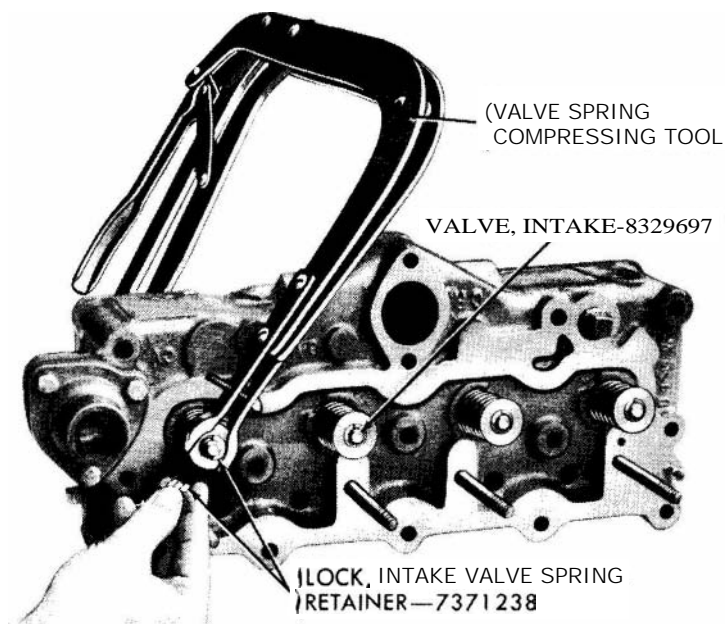

RA PD 181045

Figure 34. Removing intake valve.

- (2) **Run a $\frac{3}{8}$ -inch round wire brush through the intake valve guides.**
- (3) Clean the intake valves on a wire wheel, making sure that all carbon is removed from the top and the underside of the valve heads and that all gum and varnish deposits are removed from the valve stems.

Wire brush and clean the valve springs, the valve spring retainers, and the valve spring retainer locks.

b. Inspection.

- (1) *Cylinder head.* Inspect the cylinder head for cracks, deep gouges on the finished surfaces, or other damage which would make the cylinder head unfit for use. Inspect all tapped openings and mark for repair (*c* below) any damaged threads or broken stud ends.
- (2) *Intake valves.* Replace any worn, pitted, or corroded valves that cannot be cleaned with a wire brush. Replace any valves whose seats are pitted, burned, or corroded so badly that they cannot be cleaned with a light cut on the valve refacing tool (*c*(2) below). Visually inspect the valve stems for marks of scoring or abrasion, and replace the valves if such marks are present. Replace any valves with bent stems. (Bent valve stems will become immediately apparent when the valve is mounted in the valve refacing machine (*e*2(2) below). Check the diameter of the valve stem at two or three places along the length of the stem with a micrometer. If any of the measurements are less than those specified in repair and rebuild standards (par. 149a), replace the valve.
- (3) *Intake valve springs.* Visually examine the springs and replace any springs which are deformed or obviously damaged. Measure the overall free length of the springs and replace any that do not measure $1\frac{1}{32}$ inch. Check each valve spring in a valve spring tester (*fig.* 35). If the tester dial indicator registers less than 70 psi when the spring is compressed to $1\frac{11}{16}$ inch, the spring must be replaced.

Note. Exhaust and intake valve springs look alike, but are different. They must not be interchanged.

- (4) *Intake valve spring retainers, spring retainer locks, and spring retainer oil seals.* Normally there is very little wear of the intake valve spring retainers or the retainer locks and these parts can usually be used again. However, they must be visually inspected and replaced if they are found to be deformed or damaged. Replace all of the intake valve spring retainer oil seals.

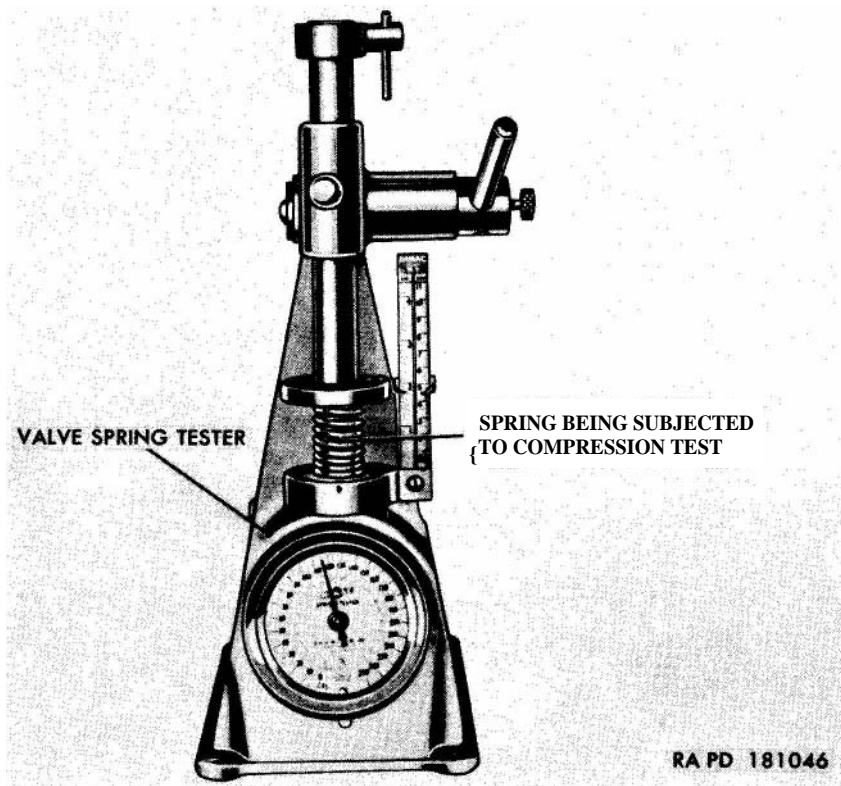

Figure 35. Checking valve spring.

(5) *Intake valve guides.* Although there is usually very little wear of the intake valve guides, each guide must be carefully checked to make sure it is within the tolerances given in the repair and rebuild standards (par. 149b). The most practical method of checking the amount of clearance between the valve stem and the guide is to insert a new valve into the guide and move the valve from side to side noting the amount of clearance by the use of a dial indicator suitably mounted. If the clearance is found to be excessive, replace the guide (c(1)(b) below).

c. *Repair.*

(1) *Cylinder head.*

- (a) Remove any broken stud or bolt ends either by drilling them out or extracting with a tool designed for this purpose. Run a tap into the threaded holes to clean rough or damaged threads.
- (b) If any of the intake valve guides are to be replaced (b (5) above), drive the guides out of the cylinder head using

the driver only of the remover and replacer 41-R-2379-25 (fig. 36), Check the dimensions of the valve guide bores as specified in repair and rebuild standards (par. 144a).

- (c) To install the intake valve guides, start the tapered end of the guide into position from the bottom of the cylinder head. Using the remover and replacer 41-R-2379-25 (driver and intake valve guide adapter) (fig. 37) drive the valve guides into the head until the adapter seats against the cylinder head. When properly positioned, the end of the guide is just flush with the end of the valve guide bore in the cylinder head (fig. 29).

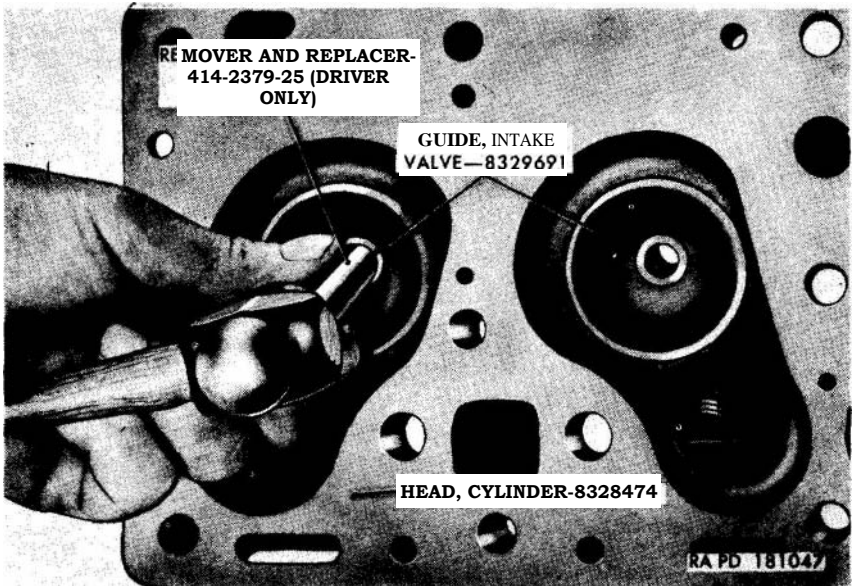

Figure 36. Removing intake valve guide using remover and replacer 41-R-2379-25.

- (d) Run a $\frac{3}{8}$ -inch reamer through each intake valve guide after completion of the installation (fig. 38). Use care to keep the reamer perpendicular to the head.
- (e) Using a valve reseating tool, grind the valve seats in the head at an angle of 45° to the axis of the valve stem, just enough to true the seats and to remove imperfections. Maintain the width of the seat at three thirty-seconds of an inch but not wider than one-eighth of an inch. After grinding the seats, check for concentricity. The total out-of-round of the valve seat must not exceed 0.002 inch. Regrind the seat, if necessary, to bring it within this tolerance.

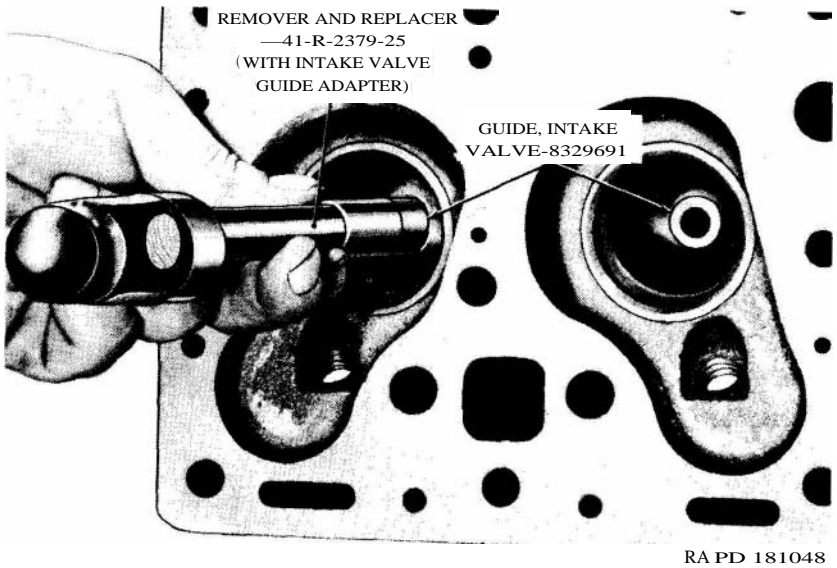

Figure 37. Installing intake valve guide using remover and replacer 41-R-2379-25.

- (f) Reface or replace the intake valves as instructed in (2) below and then lap them in the cylinder head intake valve seats.
- (2) *Intake valves.* Using a valve refacing tool, grind the seat area of the intake valves to a 45-degree angle. Remove only enough metal to clean the seat and eliminate pits and burned areas. If it is necessary to remove so much metal

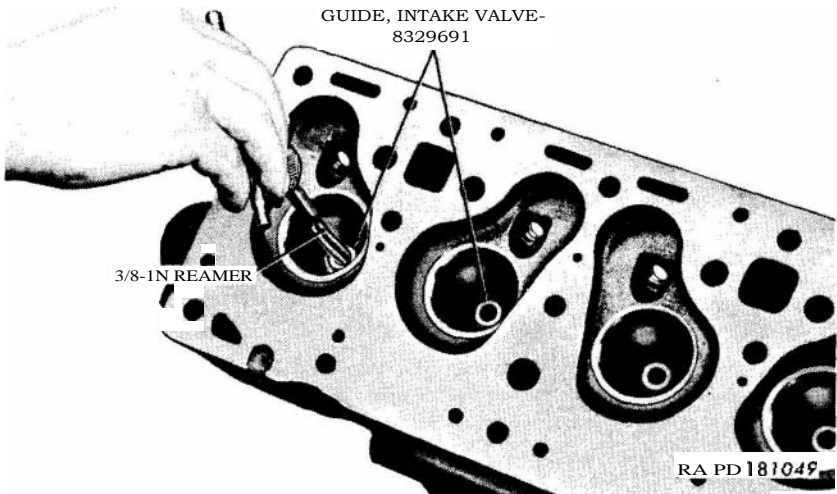

Figure 38. Reaming intake valve guide.

from the face of the valve that the edge of the head is reduced to less than $\frac{1}{2}$ -inch thickness, replace the valve.

Note. If the stem of an intake valve is bent, it will be apparent when the valve is clamped in the refacing machine. Discard such valves and replace with new ones.

55. Assembly

(fig. 39)

a. Install the four rocker arm shaft bracket studs (fig. 40) in the top of the cylinder head. Install the intake valves in the cylinder head and set the cylinder head on the work bench, finished face down, on four 1-inch square wood blocks, with the blocks located directly under the valves to hold them against their seats in the head.

b. Set the intake valve springs (fig. 40) in place over the stems of the intake valves (*JJ*) with the more closely wound coils of the springs seated against the cylinder head.

Note. Exhaust and intake valve springs look alike but are different. They must not be interchanged.

Set the intake valve spring retainers (*W*) in place on the intake valve springs (*W*). Using a standard valve spring compressing tool (fig. 34), compress the valve springs and install the intake valve spring retainer oil seals (*U*) and the intake valve spring retainer locks (*T*).

c. Coat the threads of the three square-head pipe plugs (two $\frac{1}{4}$ -inch (*AA*), and one $\frac{1}{2}$ -inch (*CC*)) with plastic type gasket cement and install them in the tapped holes in the top of the cylinder head. Install the $\frac{1}{8}$ -inch slotted-headless pipe plug (*FF*) and the $\frac{1}{4}$ -inch inverted flared tube connector (*BB*) in the oil passage in the cylinder head.

d. Set the water temperature thermostat (*B*) in the thermostat opening in the cylinder head. Coat both sides of the thermostat housing gasket (*C*) and the threads of the attaching cap screws with plastic type gasket cement and install the gasket and the thermostat housing (*D*), securing the housing in place with three $\frac{5}{16}$ -18NC-2 x $\frac{7}{8}$ lockwasher cap screws (*E*).

Section VI. REBUILD OF ROCKER ARMS AND SHAFT ASSEMBLY

56. Disassembly

a. Remove the two studs temporarily installed in the rocker arm shaft brackets at the ends of the rocker arm shaft (par. 32b).

b. Slide the rocker armshaft brackets, the four rocker arm assemblies, and the two rocker arm shaft springs off the rocker arm shaft (fig. 41). Remove the two rocker arm shaft lock screws from the two remaining rocker arm shaft brackets and slide the brackets off the shaft.

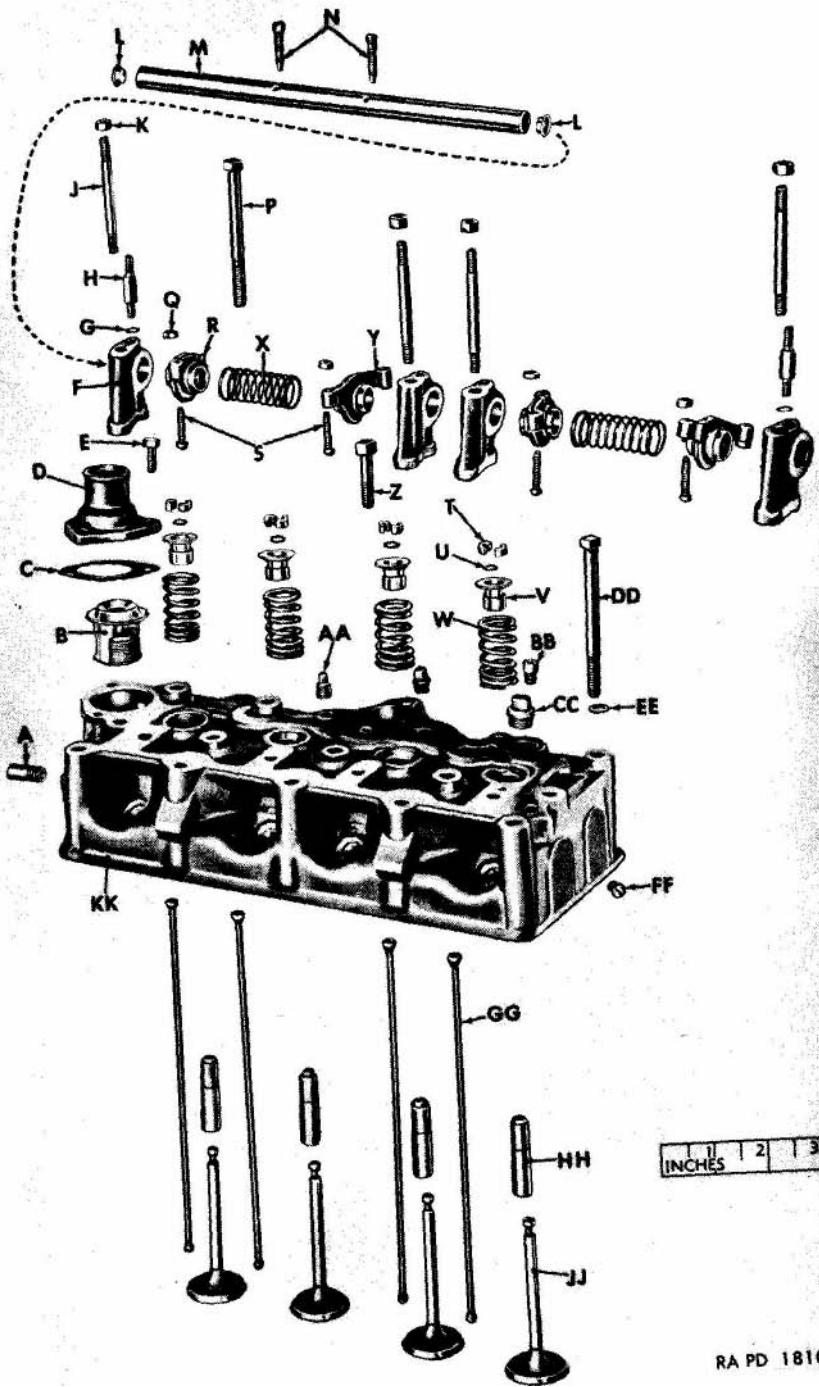

Figure \$9. Cylinder head and rocker arm assembly—disassembled view.

RA PD 181050

- A -Nipple, hose, water pump bypass-8328460
 B—Thermostat, water temperature-7348571
 C Gasket, thermostat housing-8328456
D—Housing, thermostat—8328459
E—Screw, cap, lockwasher, $\frac{5}{16}$ -18NC-2 x $\frac{7}{8}$ —7372812
 F—Bracket, rocker arm shaft-8329712
 G—Washer, lock int-teeth, $\frac{5}{16}$ -inch—138538
 H—Stud, rocker arm cover, $\frac{5}{16}$ -24NF-2—8329714
J—Stud, rocker arm shaft bracket-8329679
 K—Nut, lock, %-24NC-2-7744472
L—Plug, rocker arm shaft—WO-648807
 M—Shaft, rocker arm, with plugs, assy-8329720
 N—Screw, lock, rocker arm shaft-8329719
 P—Screw, cap, $\frac{7}{16}$ -14NC-2 x 4%—8329678
 Q—Nut, lock, $\frac{5}{16}$ -24NF-2—124920
R—Arm, rocker, LH, assy-8329710
 S—Screw, adjusting, intake valve-8329718
 T—Lock, intake valve string retainer-7371238
 U—Seal, oil, retainer, intake valve spring-8329694
 V—Retainer, intake valve spring-8329693
 W—Spring, intake valve-8329695
 X—Spring, rocker arm shaft-8329721
 Y—Arm, rocker, **RH**, assy-8329711
 Z—Screw, cap, $\frac{7}{16}$ -14NC-2 x 1 $\frac{1}{6}$ —8328474
 AA—Plug, pipe, sq-hd, $\frac{1}{4}$ -inch—219190
 BB—Connector, inv flared tube, $\frac{1}{4}$
CC—Plug, pipe, sq-hd, $\frac{1}{2}$ -inch—108868
 DD—Screw, cap, $\frac{7}{16}$ -14NC-2 x 4%—8329677
EE—Washer, plain-8329680
 FF—Plug, pipe, sltd-hdls, $\frac{1}{8}$ -inch—645256
 GG—Rod, push, intake valve-8329717
HH—Guide, intake valve-8329691
JJ—Valve, intake—8329697
 KK—Head, cylinder-8328474

Figure 39.—Continued

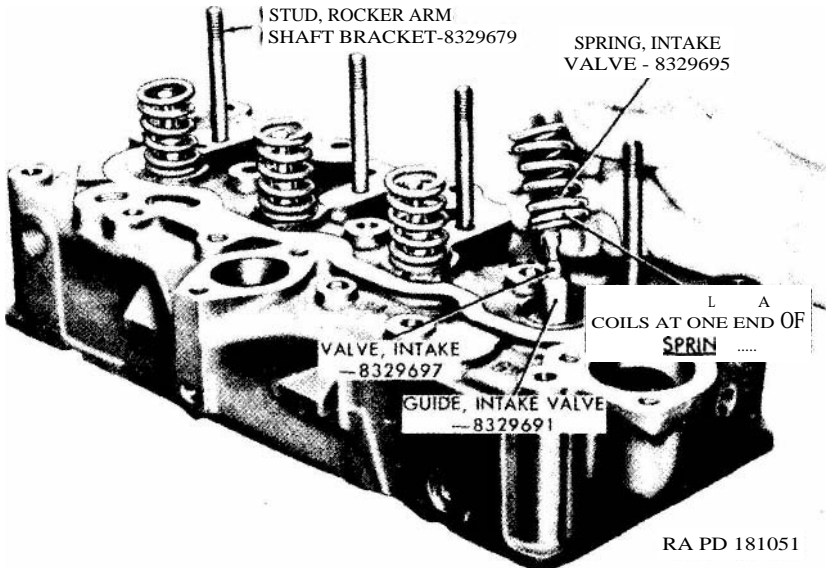

Figure 40. Installing intake valve springs.

c. Insert a screwdriver under the edge of the rocker arm shaft plugs (fig. 41) at each end of the rocker arm shaft, and pry the plugs out of the shaft.

d. Remove the intake valve adjusting screw locknuts from each of the rocker arm intake valve adjusting screws. Remove the screws from the rocker arms.

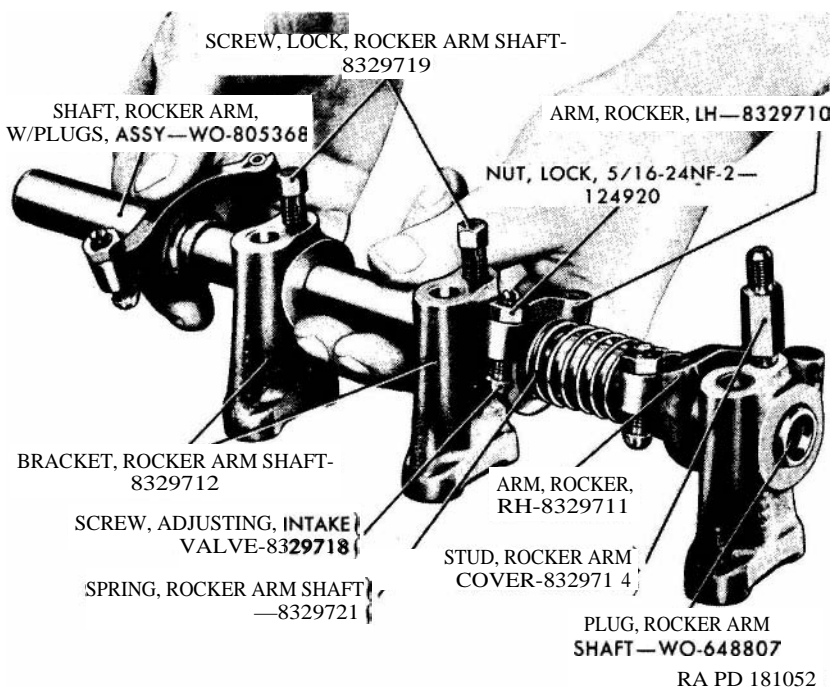

Figure 41. Disassembling rocker arm assembly.

57. Cleaning, Inspection, and Repair

Note. Before performing the operations given in this section, refer to the general instructions given in paragraphs 24 through 29 relative to the cleaning inspection, and repair of engine parts.

a. *Cleaning.* Run a round wire brush through the bore of the rocker arm shaft, and clean out the drilled oil holes. Clean out the oil holes in the rocker arm shaft brackets, and the oil holes and oil grooves in the bores of the rocker arm.

b. *Inspection and Repair.*

- (1) *Rocker arm shaft.* Replace the shaft if there are scores or abrasion marks at any point along the length of the shaft. Measure the diameter of the shaft at the areas which form the rocker arm bearing points. Replace the shaft if it shows wear beyond the minimum diameter specified in repair and

rebuild standards (par. 145). Check the shaft for alinement in a fixture designed for this type of service or by rolling the shaft across a smooth level surface. If the shaft will not roll freely, or if it rolls with a bumping motion, the shaft is out of alinement and must be replaced.

- (2) *Rocker arms and intake valve adjusting screws.* Measure the bores and the widths of the rocker arms and replace the arms if the dimensions do not conform to those specified in repair and rebuild standards (par. 145). Inspect the threads in the adjusting screw hole in the rocker arm and if necessary clean with a properly sized tap. Replace the adjusting screw locknut or the adjusting *screw* if either part is damaged or deformed.
- (3) *Rocker arm shaft brackets.* Measure the bore in the bracket and replace the bracket if the dimension exceeds that given in repair and rebuild standards (par. 145). Inspect the threads in the tapped hole in the top of the bracket and if necessary clean with a properly sized tap. If either side of the bracket is worn or scored replace the bracket.

58. Assembly

(fig. 39)

a. Install the two rocker arm shaft plugs (L), one in each end of the rocker arm shaft (M). Slide two rocker arm shaft brackets (F) onto the rocker arm shaft. Aline the tapped holes in the brackets with the drilled holes in the top of the rocker arm shaft and install the rocker arm shaft lock screws (N), making sure the points of the screws enter the drilled holes in the shaft.

b. Screw the intake valve adjusting screws (fig. 41) into the rocker arm and install the $\frac{3}{16}$ -24NF-2 locknuts (Q).

Note. The rocker arms are paired ; that is, two of the arms are angled to the right and two are angled to the left. One of each type is used on each end of the rocker arm *shaft*.

Slide one of the rocker arms onto the shaft so that the intake valve adjusting screw (S) in the rocker arm is on the same side of the rocker arm shaft as the mounting hole in the bracket and also so that the adjusting screw end of the rocker arm angles away from the bracket.

c. Install a rocker arm shaft spring (X) on the shaft against the rocker arm. Install the second rocker arm on the shaft in the same manner as in *c* above, except that the adjusting screw end of the arm is to be angled toward the center rocker arm bracket (**fig. 41**).

Refer to the *note* in *b* above.

d. Install a rocker arm shaft bracket on the end of the shaft so that the worn side of the bracket (par. 57b (3)) is facing away from

the rocker **arm**. Temporarily secure the bracket in place by **installing** a rocker arm cover stud (H) upside down (par. 32b) in the tapped opening in the top of the support.

e. Assemble the parts on the opposite end of the rocker arm shaft repeating *c* and *d* above.

Section VII. REBUILD OF CONNECTING ROD AND PISTON ASSEMBLIES

59. Disassembly

a. Remove the two compression rings, the oil control ring and the oil control *ring* expander from the piston. Do not remove the bolts from the lower end of the connecting rod unless they are damaged.

b. Clamp the connecting rod and piston assembly in a bench vise and remove the piston pin lock bolt and lockwasher (fig. 42).

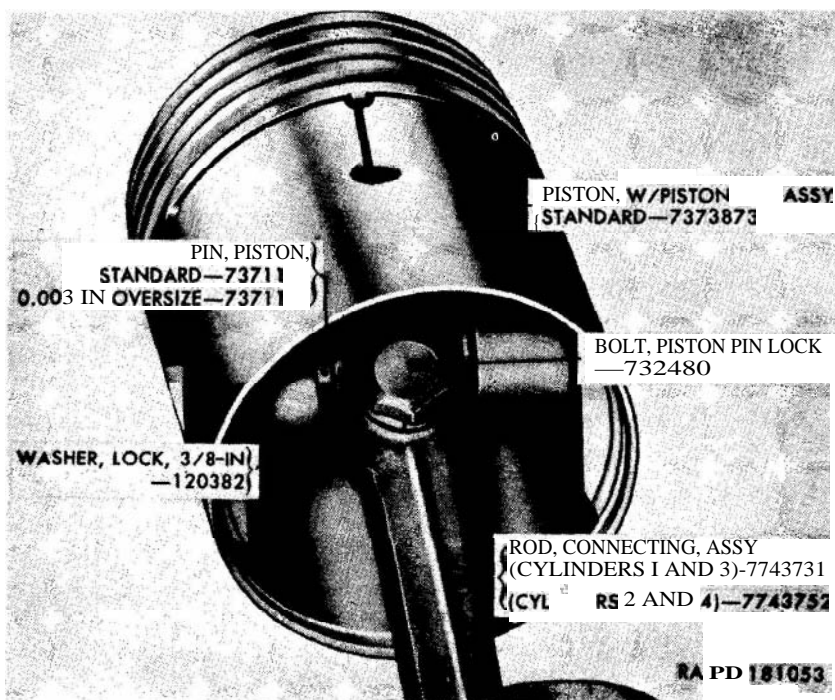

Figure 42. Location of **piston** pin lock bolt.

c. Drive the piston pin out of the piston and connecting rod, using the improvised piston pin remover and replacer (**fig-48**).

Note. To avoid the possibility of mushrooming the end of the pin, which might occur if the driving force were applied to the end of the pin, the piston **pin** tool must *be* inserted into the bore of the pin so that the force is exerted against the shoulder in the bore of the piston pin.

60. Cleaning, Inspection, and Repair

Note. Before performing the operations covered in this paragraph, refer to the general instructions given in paragraphs 24 through 29 relative to the cleaning, inspection, an repair of engine parts.

a. Cleaning.

- (1) Clean all carbon, **gum**, and lacquer deposits from both the inner and outer surfaces of the pistons. Use a ring groove cleaner or, a broken ring filed to a sharp square edge to clean the carbon from the piston ring grooves and the insulator groove.
- (2) Clean all carbon, gum, and lacquer deposits from the connecting rod and piston pin. Run a length of wire through the oil spray hole near the lower end of the connecting rod (fig. 43) to clear the hole of hardened oil deposits or foreign material.

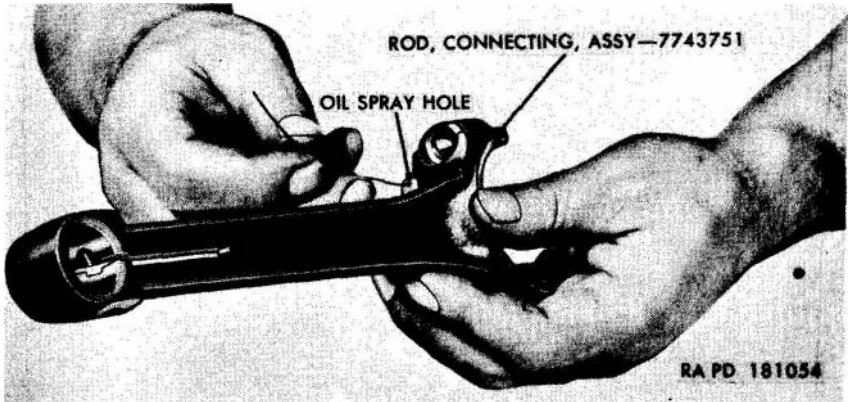
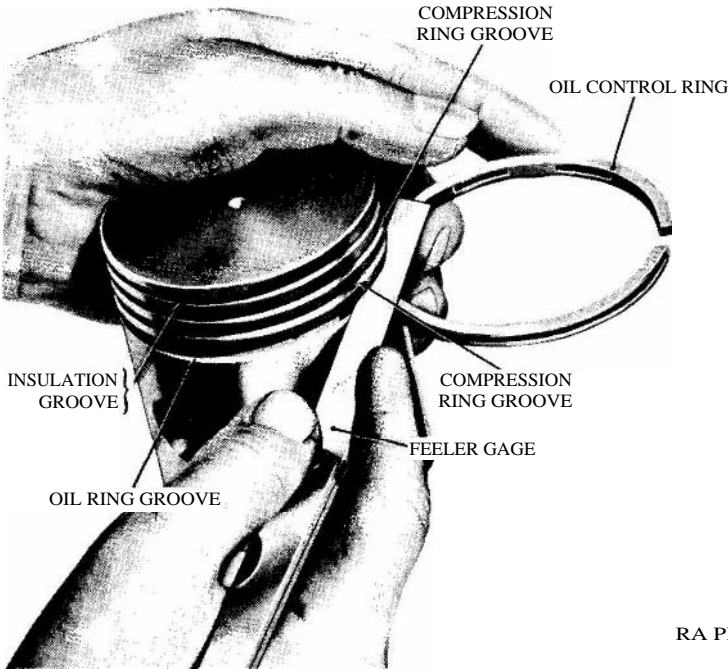

Figure 43. Cleaning connecting rod oil spray hole.

b. Inspection and Repair.

- (1) Replace pistons if there are any broken or cracked areas on the inside surface. Replace pistons if any of the ring lands are chipped, broken, or rounded on the edges; or if the piston is scored, scratched or burned so seriously that the **imperfections** cannot be removed with a hand honing stone or crocus cloth.
- (2) Check the dimensions of the top and bottom of the piston, and replace if these dimensions are not within the limits specified in repair and rebuild standards (par. 147a).
- (3) Using a feeler gage, and the new rings that are subsequently to be installed on the pistons, check the width of the two compression ring grooves and the oil ring groove (fig. 44). Replace the piston if the widths of the grooves are not within the limits given in repair and rebuild standards (par. 147b).



RA PD 181055

Figure 44. Checking width of piston ring grooves.

- (4) Check the dimensions and the alinement of the piston pin bores in the piston and the connecting rod and replace the piston or the connecting rod if the wear or misalinement is so great that it cannot be eliminated by line boring 0.003 inch oversize.

Note. Piston pins are available in 0.003 inch oversize for service use.

- (5) Within manufacturing tolerances, pistons and cylinder block piston bores vary in size by a fraction of a thousandth of an inch. Since this is true, in order to obtain the most satisfactory running clearance between a piston and a cylinder, the cylinder must be fitted with a piston that is oversize approximately the same fraction of a thousandth inch that the bore is oversize; or vice versa. Fitting pistons to cylinders is a selective, or trial and error operation ; that is, if the first piston does not meet the standard (*c*) below) others must be tried until the correct clearance is obtained (*d*) below). Fit pistons to cylinders (fig. 45) as follows :
 - (a) Slide a piston pin into the bore of the piston to serve as a finger gripping surface.
 - (b) Attach a 0.003-inch feeler gage, 34-inch wide, and 10 to 12 inches long to the spring tension scale.

- (c) Lower the full length of the 0.003-inch feeler gage (fig. 45) into one of the cylinders of the previously rebuilt cylinder block. Lower the full length of the piston (upside down) into the same bore and so positioned that the feeler gage is directly opposite the T-slot in the piston. Pull up on the spring tension scale and note the reading on the indicator as the feeler is withdrawn from the cylinder bore. If a reading of from 5 to 10 pounds is obtained, the piston is satisfactory for use in that bore. If a reading of less than 5 pounds is obtained, the piston is too loose; if more than 10 pounds, the piston is too tight.
- (d) If either of the latter readings is obtained, try the piston in the next bore. Continue in this manner until all cylinder bores are properly fitted, replacing any pistons which cannot be fitted.

Note. The piston fitting operation is generally begun at one end of the cylinder block and carried through each bore in turn to the opposite end of the block. To simplify the subsequent assembly of

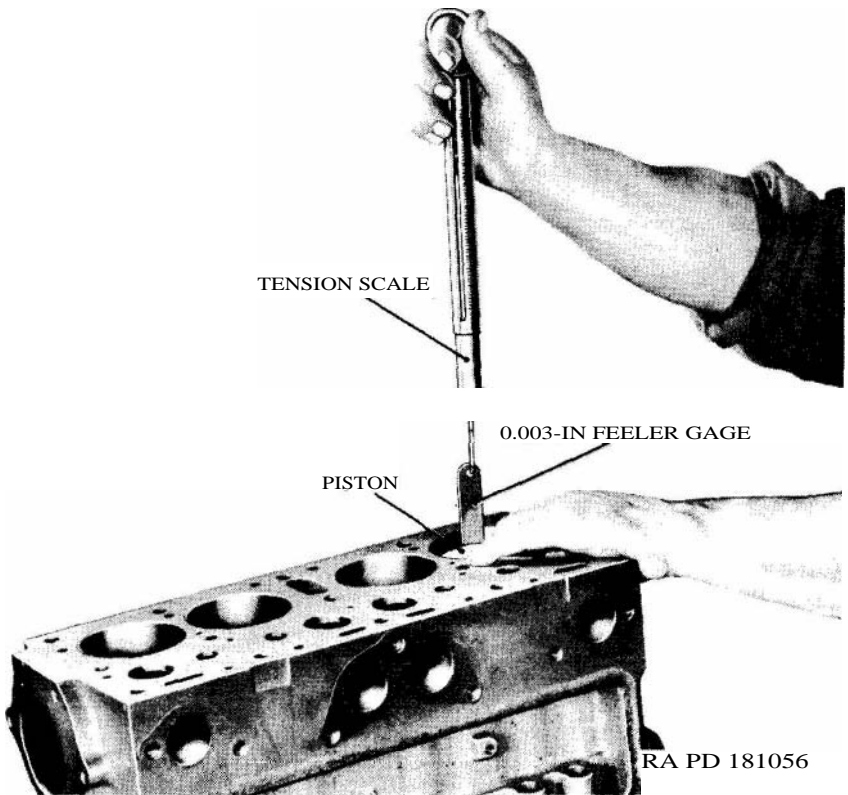
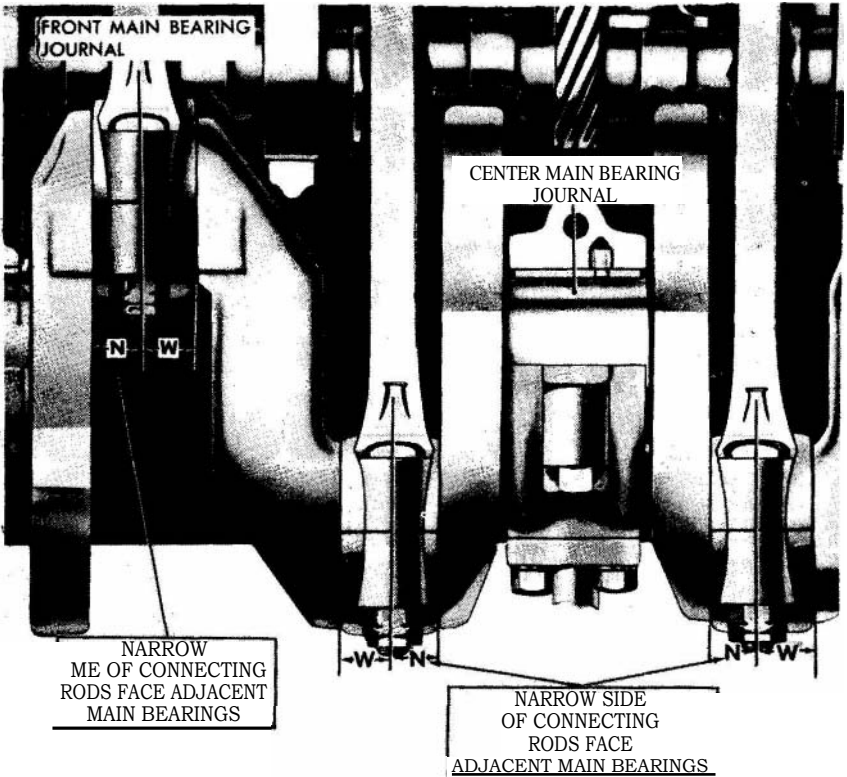

Figure 45. Fitting pistons to cylinders.

the piston in the cylinder block, mark the top of the piston with the number of the cylinder to which it was fitted.

- (6) Measure the diameter of the piston pin and replace the pin if the dimensions do not conform to specifications given in repair and rebuild standards (par. 147d).
- (7) Use a connecting rod alining fixture to check the alinement of the rod (repair and rebuild standards (par. 146)) and an approved procedure to straighten those found to be out of alinement. Replace connecting rods that cannot be satisfactorily straightened.

Note. The connecting rods are offset at the crankshaft end (fig. 46) and particular care must be taken to see that the replacement rod is the same as the discarded rod. Stamp both pieces of the new rod with the same cylinder identifying number as stamped on the discarded rod. Refer to figure 48 for location of cylinder Identification numbers.



RA PD 181057

Figure 46. Connecting rods at **crank shaft**—installed view.

61 . Assembly

(fig. 47)

a. The assembly operation is described for one assembly. Assemble the remaining three assemblies by following the same series of operations as given for the one assembly.

b. Clamp the connecting rod (C) in a bench vise approximately three inches from the piston pin end. Note the cylinder identifying number stamped on the side of the rod (fig. 48) and select the piston with the corresponding number (par. 60b (7)).

c. Start the piston pin into the piston with the lock bolt groove in the piston pin facing the bottom of the piston. Assemble the piston and connecting rod with the T-slot in the piston on the side of the rod opposite the oil spray hole in the lower end of the rod. Aline the piston pin bores in the rod and the piston, and holding the connecting rod in the center of the piston so that the lock bolt groove in the piston pin will be in line with the lock bolt hole in the rod, drive the pin into position using the improvised piston pin remover and replacer (fig. 48).

d. Install the piston pin lock bolt and lockwasher (fig. 42) .

e. Select a new set of rings and check the end gaps of the rings as follows:

- (1) Insert one of the rings selected into one of the cylinder bores. Using the piston (held upside down) fitted to that cylinder as a plunger, force the ring down into the cylinder the full length of the piston. Check the gap between the ends of the ring with a feeler gage (fig. 49).
- (2) If the gap is less than 0.008 to 0.013 inch, remove the ring and file the ends of the ring with a fine cut file until the correct gap is obtained. If the gap is greater than that specified, remove the ring and use the next oversize ring set. Repeat this procedure on each of the three piston rings and upon completion of the operation install the set of rings on the piston as instructed in *f* below.

f. Install the piston rings on the pistons using a piston ring applier as follows :

- (1) Install the oil regulating ring expander in the lower ring groove by hand (applier not required).
- (2) Install the oil regulating ring (slotted ring) in the lowest ring groove, and position the ring so that its gap is on the opposite side of the piston from the ends of the ring expander.
- (3) Install the two compression rings on the piston so that the grooves on the inner edges of the rings face up (toward the top of the piston).

Note. The two compression rings although alike in diameter and in thickness are unlike in color and in texture of metal (fig. 50). They must not be interchanged.

- A—NUT, JAM, 3/8-IN—107823
 B—NUT, 3/8-24NF-2—7744472
 C—ROD, CONNECTING
 (CYLINDERS 1 AND 3-7743751)
 (CYLINDERS 2 AND 4-7743752)
D—BOLT, 3/8-24NF-2 X 2-1/4-7744471
 E—PISTON, W/PIN, ASSY (STANDARD)—7372873
 F—RING SET, PISTON (STANDARD)—7371146
 G—PIN, PISTON (0.003-IN OVERSIZE)—7371145

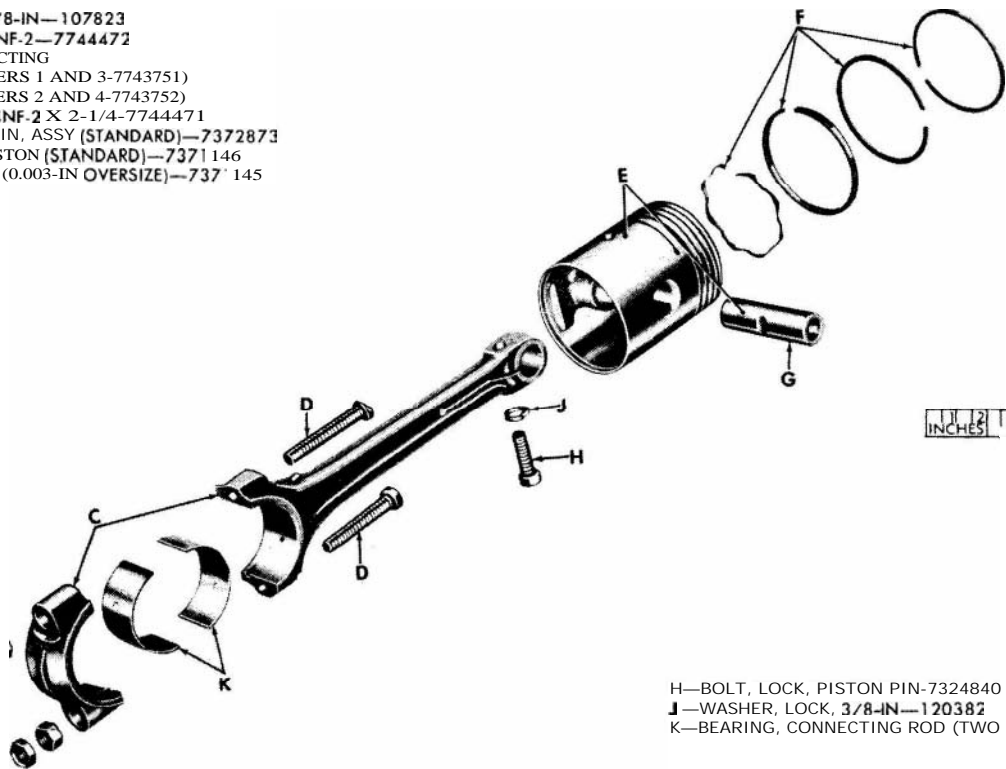

- H—BOLT, LOCK, PISTON PIN-7324840
 J—WASHER, LOCK, 3/8-IN—120382
 K—BEARING, CONNECTING ROD (TWO HALVES)—5701528

RA PD 181058

Figure 47. Piston and connecting rod assembly—disassembled view.

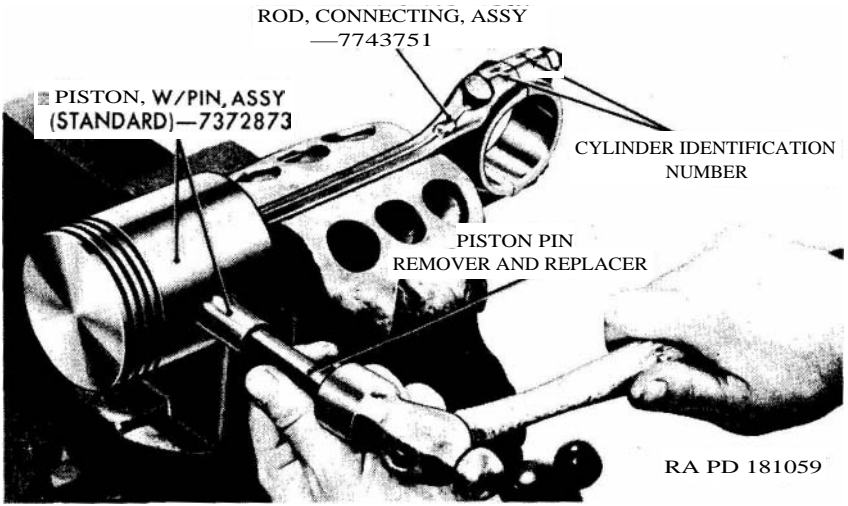

Figure 48. Installing piston pin.

Install the dark, rough textured ring in the ring groove directly above the oil regulating ring. Install the light colored, highly polished ring in the groove nearest the top of the piston. Turn the rings so that the ring gaps are on opposite sides of the piston.

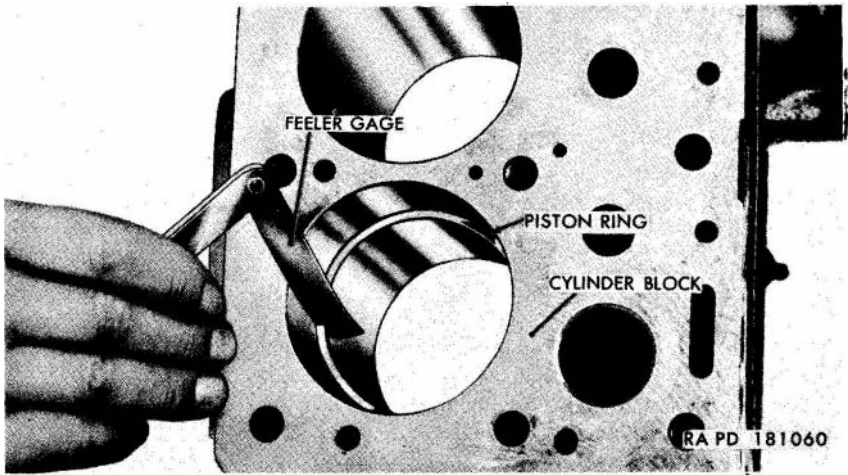
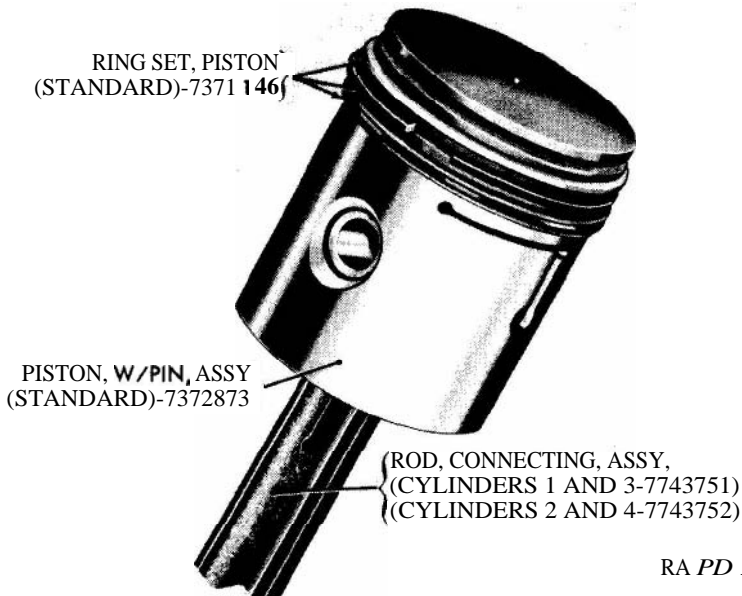

Figure 49. Checking piston ring gap.



RA PD 101'00

Figure 50. Piston rings installed on piston.

Section VIII. REBUILD OF INTAKE AND EXHAUST VALVE TAPPETS

62. Disassembly

Remove the exhaust valve adjusting screw from the end of the exhaust valve tappet. The intake valve tappet, being one piece (fig. 51) is subject only to the cleaning and inspection operations.

63. Cleaning, Inspection, and Repair

Note. Before performing any of the operations given in this section, refer to the general instructions given in paragraphs 24 through 29, relative to the cleaning, inspection, and repair of engine parts.

a. Cleaning. Clean and inspect the intake and exhaust valve tappets for damage.

b. Inspection, and Repair.

- (1) Check the threads and the fit of the exhaust valve adjusting screw in the exhaust valve tappets (fig. 51). The fit of a screw should be such that a wrench is required to turn it into or out of the tappet. Replace the worn part, either the screw or the tappet, or both, if there is looseness between the parts.
- (2) Check the clearance of the tappets in their bores in the cylinder block (repair and rebuild standards (par. 142b)). If there is excessive clearance between the bore and the tappet, try new unused tappet in the bore. If the clearance is still

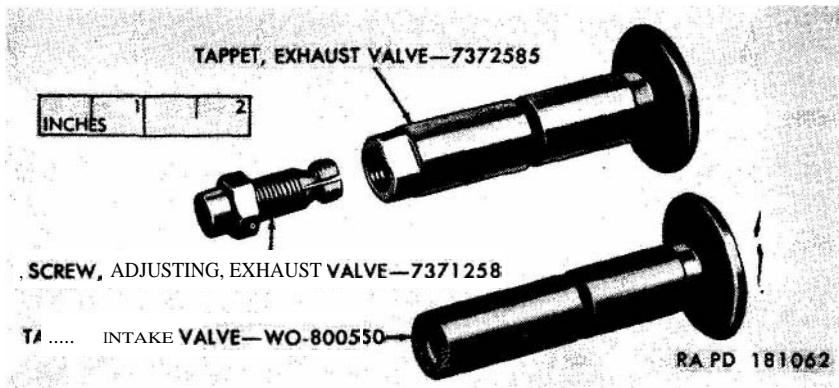

Figure 51. Intake and exhaust valve *tappets*—*disassembled* view.

excessive it indicates that the tappet bore in the cylinder block is worn. In this event, ream the particular tappet bore affected to accommodate an oversize tappet (0.004 inch oversize) in the particular tappet bore.

Section IX. REBUILD OF CRANKSHAFT

64. Cleaning

Note. Before performing any of the operations given in this section, refer to the *general* instructions given in paragraphs 24 through 29, relative to the cleaning, inspection, and repair of engine parts.

Clean the crankshaft, taking particular care to clean the drilled oil passages of sludge or gum deposits.

65. Inspection and Repair

a. Carefully inspect the crankshaft for cracks. Use **magnaflux** equipment if available. Replace the crankshaft if cracks are found in any area.

Note. If the crankshaft is replaced, the flywheel must be fitted to the new crankshaft (par. 70c).

b. Mount the crankshaft on V-blocks or lathe centers, and check the alinement of the crankshaft main bearing journals (repair and rebuild standards (par. 143a)).

c. Use a micrometer to check the amount of wear or the extent of out-of-roundness of the crankshaft bearing and connecting rod bearing journals (repair and rebuild standards (par. 143b and c)) . If the journals are unevenly worn, out-of-round, or tapered, the crankshaft must be ground (*d* below) to an undersize.

d. When necessary, the crankshaft may be ground and fitted with **undersize bearings**. In general, the crankshaft should not be ground to exceed 0.030 inch undersize.

Section X. REBUILD OF CAMSHAFT

66. Cleaning

Note. Before performing any of the operations given in this section, refer to the general instructions given in paragraphs 24 through 29, relative to the cleaning, inspection, and repair of engine parts.

Clean the camshaft as required.

67. Inspection and Repair

a. Inspection. Examine the camshaft gear teeth for damage. If teeth are damaged, replace the gear. Mount camshaft on centers or on V-blocks and check for runout (repair and rebuild standards (par. 148a)). Use a micrometer to measure the amount of wear of the camshaft bearing journals (repair and rebuild standards (par. 148b)).

b. Repair. The camshaft cannot be repaired. If it has been damaged or if the journals are worn beyond limits, it must be replaced.

Section XI. REBUILD OF FLYWHEEL ASSEMBLY

68. Cleaning

Note. Before performing any of the operations given in this section, refer to the general instructions given in paragraphs 24 through 29, relative to the cleaning, inspection, and repair of engine parts.

Clean the flywheel and ring gear assembly.

69. Inspection

a. If the friction face of the flywheel is scored or worn so badly that it cannot be corrected by refacing, replace the flywheel and flywheel ring gear assembly (fig. 52). If any of the mounting holes are misshapen or elongated, replace the flywheel.

b. Measure the inside diameter of the clutch pilot bearing and replace the bearing (par. 70b) if the dimension exceeds 0.623 inch.

c. If any of the teeth on the flywheel ring gear are broken, badly chipped or snubbed, or excessively worn, replace the ring gear (par. 70).

70. Repair

a. If the inner ends of the flywheel ring gear teeth are only slightly burred or snubbed, remove the burs and reshape the teeth using a small abrasive wheel. If, however, the teeth are broken, cracked or seriously burred, replace the ring gear as follows:

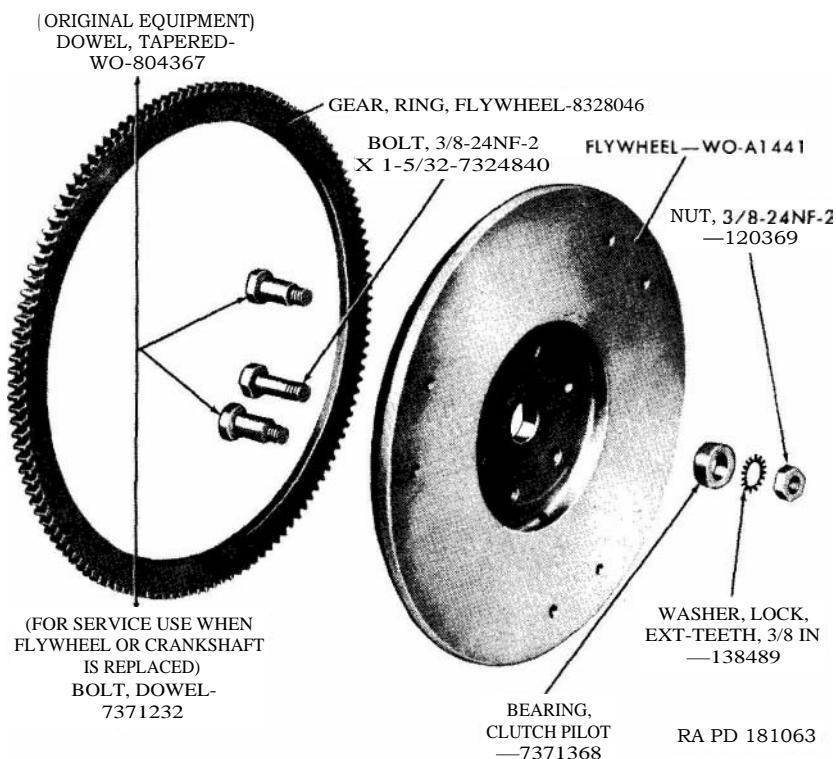

Figure 52. Flywheel assembly—disassembled view.

- (1) The ring gear is secured on the flywheel by a shrink fit, no attaching parts are used. To remove the flywheel ring gear from the flywheel, heat a small area of the gear to a cherry red, with a torch, and knock the gear off the flywheel. Take care to avoid heating the flywheel unnecessarily during the operation.
- (2) Expand the new flywheel ring gear, by the even application of heat, until the gear shows a dull straw color (approximately 400° to 500° F.). Place the gear in place on the flywheel making sure the gear is firmly seated against the flange of the flywheel. Do not move the flywheel until the gear and flywheel has cooled.
 - b. If the replacement of the clutch pilot bearing is necessary (par. 69b), press the old bearing out and the new bearing into the center hole in the flywheel.
 - c. If the old flywheel and ring gear assembly is being replaced by a new flywheel and ring gear assembly, or if the old crankshaft was replaced (par. 65a), the tapered dowel holes must be enlarged to

accommodate the *straight* dowel bolts (fig. 52) furnished with the replacement flywheel or crankshaft as follows :

- (1) Assemble the flywheel and ring gear assembly to the crankshaft with the four $\frac{1}{2}$ -24NF-2 x $1\frac{1}{2}$ bolts, the $\frac{3}{8}$ -24NF-2 nuts, and the $\frac{1}{2}$ -inch external-teeth lockwashers. Tighten the nuts securely.
- (2) Drill the tapered dowel holes with a $\frac{3}{4}$ -inch drill. Ream the holes with a $\frac{1}{6}$ -inch straight reamer. Remove the four bolts, nuts and **lockwashers** and remove flywheel from the crankshaft to permit installation of the parts in the engine assembly.

Section XII. REBUILD OF OIL STRAINER ASSEMBLY

71. Disassembly

(fig. 53)

Remove the cotter pin from the oil strainer support and remove the oil strainer assembly.

72. Cleaning, Inspection, and Repair

Note. Before performing any of the operations given in this section, refer to the general instructions given in paragraphs 24 through 29, relative to the cleaning, inspection, and repair of engine parts.

a. Cleaning. Clean the oil strainer parts of sludge or gum deposits.

b. Inspection and Repair.

- (1) Inspect the screen in the oil strainer assembly and replace if tears or punctures are found. Replace the oil strainer assembly if the screen has deteriorated to the point where it is no longer resilient or springy when flexed in the hands.
- (2) Slide the outlet end of the strainer assembly into the inlet end of the oil strainer support and test for freeness of the parts. If either part is worn or distorted so much that the parts catch or bind, the part at fault must be replaced.

73. Assembly

(fig. 53)

a. Insert the outlet end of the oil strainer assembly into the inlet end of the oil strainer support and secure in place by installing the $\frac{1}{8}$ x $1\frac{1}{4}$ cotter pin in the support.

b. Check the assembly to make sure there *is* no binding of the strainer in the support.

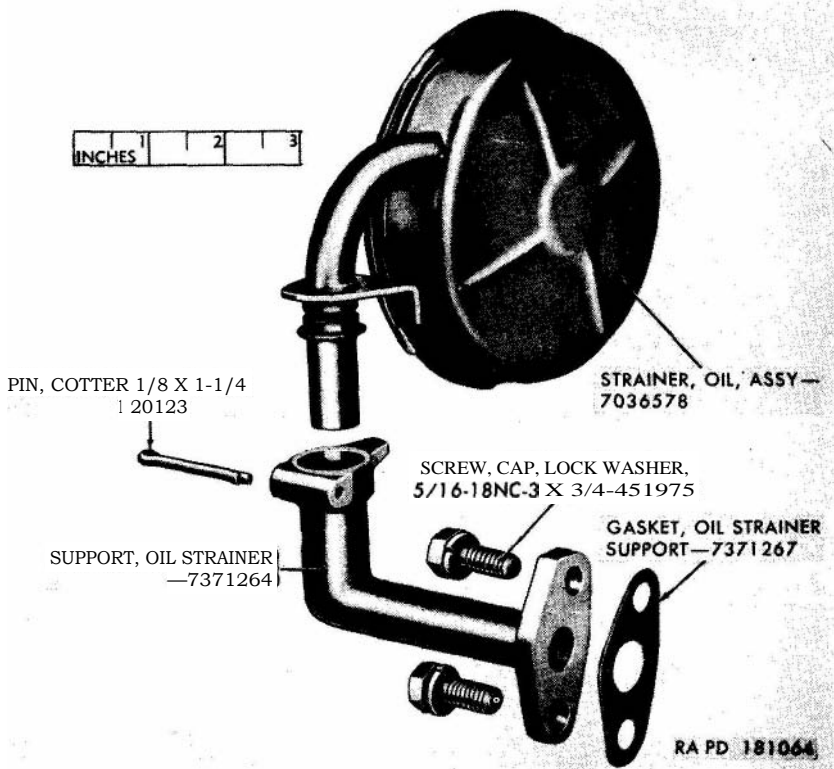

Figure 53. Oil strainer assembly—disassembled view.

Section XIII. REBUILD OF WATER PUMP ASSEMBLY

74. Disassembly

- a. Pull the water pump bearing retaining spring (fig. 54) out of the slot in the body of the water pump.
- b. Clamp the water pump in a bench vise and remove the water pump impeller (figs. 55 and 58) using puller 41-P-2958-65.
- c. Lift the water pump seal and the seal washer off the end of the water pump shaft assembly.
- d. Turn the assembly over and clamp the vise jaws on the body of the pump. Pull the fan and the water pump pulley from the end of the water pump shaft assembly, using puller 41-P-2908-240 and wrench 41-W-3248-900 (fig. 56).
- e. Tap against the impeller end of the shaft, using a soft-faced hammer, to drive the bearing and shaft assembly out of the water pump body.

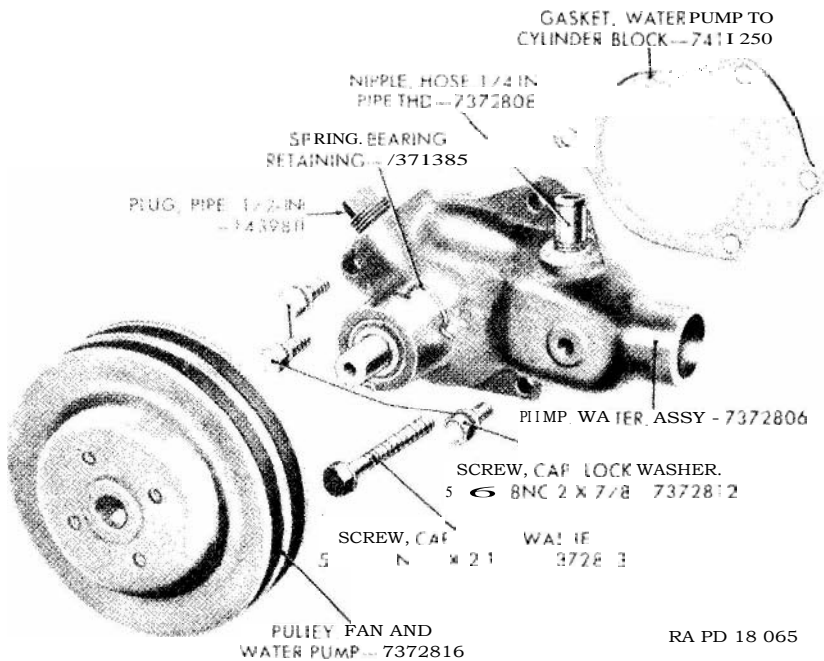

Figure 54. Water pump assembly.

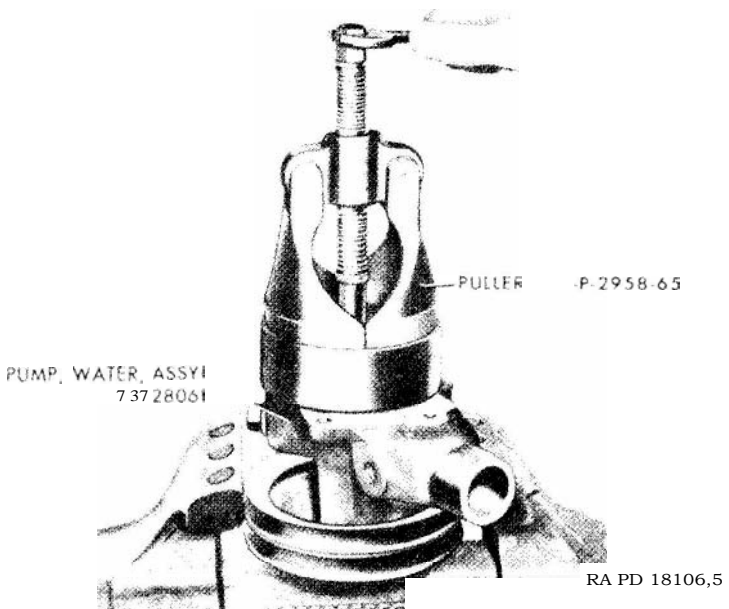

Figure 55. Removing water pump impeller.

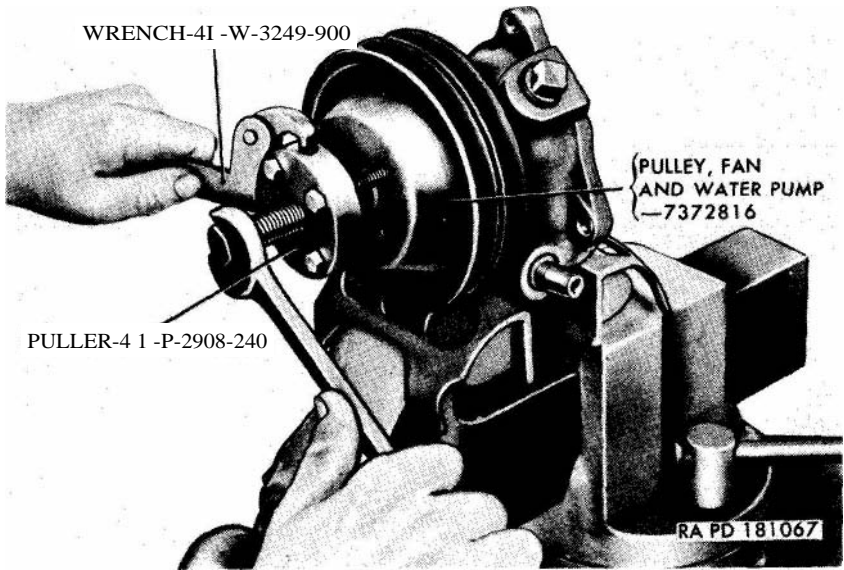

Figure 56. Removing fan and water pump pulley using puller—41-P-2908-240.

f. Do not remove either the pipe plug or the hose nipple (fig. 54) from the water pump body unless they are damaged.

75. Cleaning, Inspection, and Repair

Note. Before performing any of the operations given in this section, refer to the general instructions given in paragraphs 24 through 29, relative to the cleaning, inspection, and repair of engine parts.

a. Cleaning. Clean the water pump body and water pump parts of rust and foreign material.

b. Inspection.

- (1) The water pump shaft with bearing assembly is lubricated and sealed at the time it is manufactured. If the shaft is loose in the bearing, has end play, or binds and does not turn freely, the entire assembly must be replaced.
- (2) Inspect the seal washer seat inside the water pump body and if it is found to be rough or scored, reface the seat (*c* below).

c. Repair. When necessary the seal washer seat on the inside of the water pump body (fig. 57) may be refaced to eliminate score marks or rough spots. Use refacer 41—R-2329-700 and follow the instructions furnished with the tool.



Figure 57. Refacing water pump body teal surface using refacer 41-R-2329-700.

76. Assembly (fig. 58)

a. Start the long end of the shaft with bearing assembly into the front end of the water pump body, pressing it into the body until the front end of the bearing is flush with the front end of the body.

b. Dip the new seal and seal washer in hydraulic brake fluid. Install the seal washer and the seal, in that order, over the end of the shaft, sliding them into the body against the seal washer seat in the body.

Note. Early models were equipped with seal washer 7372811. Use preferred seal washer **WO-800003**, if available.

c. Using an arbor press, press the water pump impeller (notched end first) onto the long end of the shaft until the end of the shaft is out flush with the face of the impeller hub.

d. Press the fan and water pump pulley onto the opposite end of the shaft until the end of the shaft is flush with the face of the pulley hub.

e. Aline the bearing retaining spring (fig. 54) groove in the bearing with the slot in the body of the water pump, and install the bearing retaining spring.

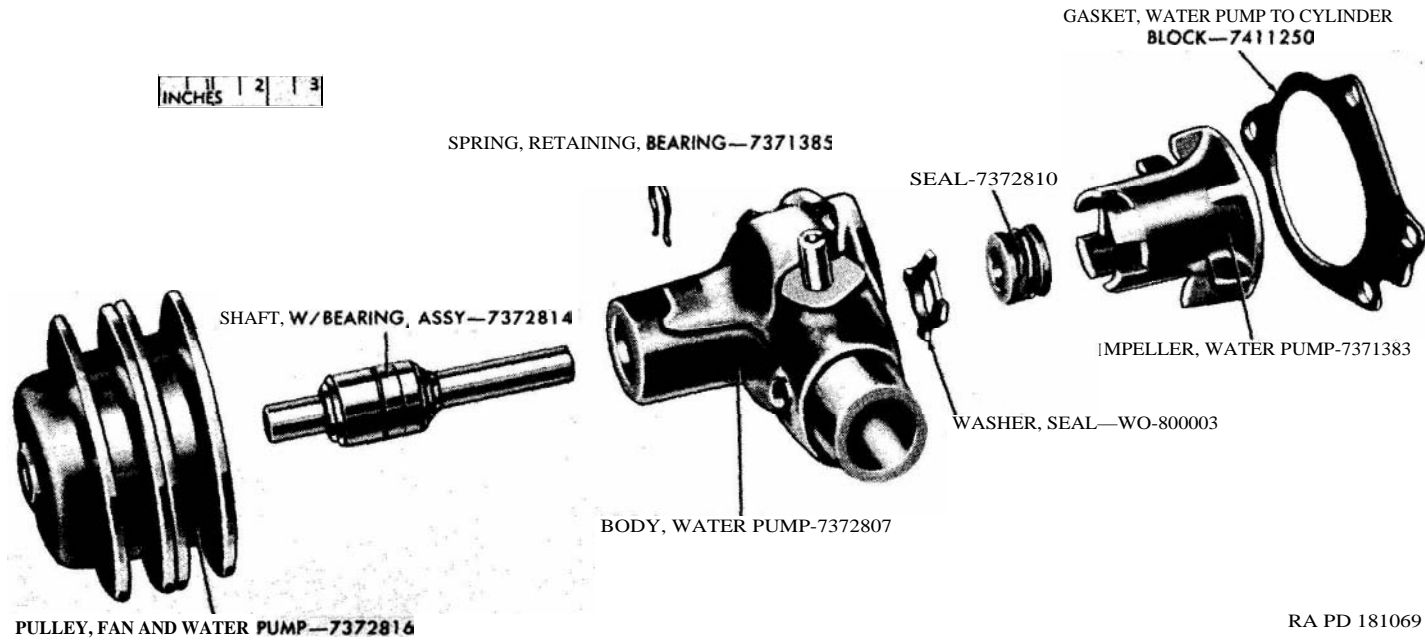

RA PD 181069

Figure 58. Water pump *a-sembly—disassembled* view.

Section XIV. REBUILD OF OIL PUMP ASSEMBLY

77. Disassembly

- a. Use an abrasive wheel or a file to cut off either end of the oil pump drive gear pin (fig. 59). Drive the pin out of the gear, using a $\frac{1}{4}$ -inch drift punch. Remove the gear from the end of the shaft.
- b. Remove the three cap screws securing the oil pump body cover (fig. 59) to the oil pump body. Remove the cover and gasket.
- c. Remove the outer rotor (fig. 61) and the inner rotor with shaft assembly from the oil pump body.

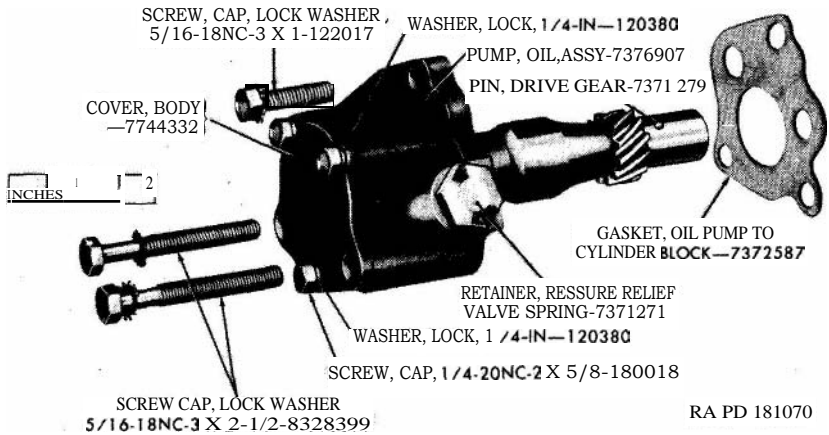

Figure 59. Oil pump assembly.

- d. Back the pressure relief valve spring retainer (fig. 59) out of the oil pump body and remove the retainer gasket, the shim, the pressure relief valve spring, and the pressure relief valve.

78. Cleaning, Inspection, and Repair

Note. Before performing any of the operations given in this section, refer to general instructions given in paragraphs 24 through 29, relative to the cleaning, inspection, and repair of engine parts.

a. *Cleaning.* Thoroughly clean all parts of the oil pump assembly giving particular attention to the oil pump body internal passages.

b. *Inspection and Repair.*

- (1) Reject any parts that are cracked, broken, or obviously worn.
- (2) Inspect the inner rotor with shaft assembly for damage to the slot in the end of the shaft, replacing the rotor with shaft assembly if the slot is burred or distorted in any way.

- (3) Inspect the inner surface of the oil pump body cover for scoring or rough spots. If such faults are present but only to a minor degree, remove them with a hand hone or crocus cloth. If the cover is seriously scored, replace the cover.
- (4) Check the cover for distortion using a straightedge and gage feeler (fig. 60). The cover must be flat and true to 0.001-inch. If a feeler gage thicker than 0.001-inch can be inserted between the straightedge and the cover, the cover must be replaced.

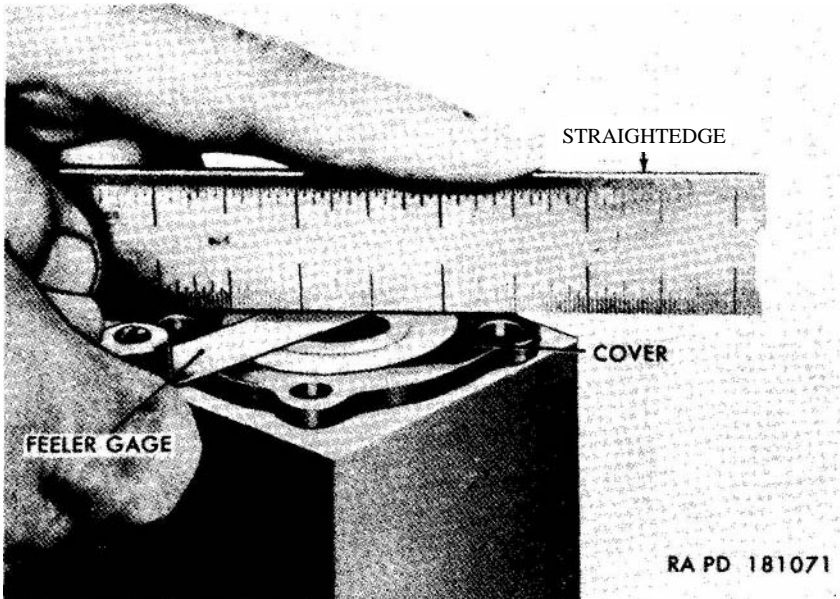

Figure 60. Checking oil pump body cover for distortion.

- (5) Insert the oil pump outer rotor and the inner rotor with the shaft into the oil pump body with bushing. Check the clearance between the outer rotor and the oil pump body with a feeler gage (fig. 61). If the clearance exceeds 0.012-inch, replace the oil pump body with bushing.
- (6) Position the two rotors so that the lobe of the inner rotor is entered as far as possible into one of the notches of the outer rotor (fig. 62). With the rotors held in this position, insert a feeler gage between the opposite inner rotor lobe and the curved section of the outer rotor and gage the clearance. If the clearance exceeds 0.010-inch, replace both rotors.

- (7) Measure the length of both rotors, and discard them if either one exceeds the length of the other by more than 0.001-inch.
- (8) The free length of the pressure relief valve spring (N, fig. 63) should be 1.640-inches. Compress the spring to $1\frac{1}{6}$ inches in the valve spring tester (fig. 35). If the tester dial indicator reads less than $9\frac{1}{2}$ psi, install one oil pressure relief valve spring shim (M, fig. 63) between the base of the tester



Figuer 61. Checking outer rotor to oil pump body clearance.

and the spring. Again compress to $1\frac{1}{6}$ inches and note reading. If necessary, add another shim. If more than two shims are required to obtain a reading or $9\frac{1}{2}$ psi, replace the spring.

79. Assembly (fig. 63)

a. Install the outer rotor (D) and the inner rotor with shaft, assembly (E) in the body of the oil pump; install the body cover (B)

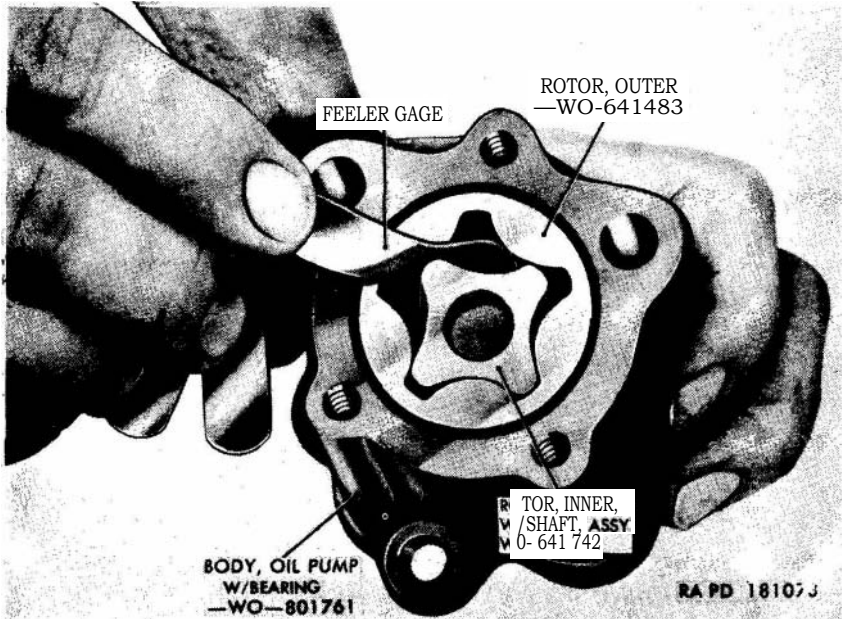

Figure 62. Checking clearance between *Omer* and outer oil pump rotors.

securing it in place with the three 14-20NC-2 x $\frac{1}{2}$ lockwasher cap screws (A).

Note. Do not install the cover gasket (C).

Tighten the cap screws to normal tension.

b. With the oil pump body and cover assembled in this manner (less gasket), grasp the end of the shaft and attempt to turn it.

Note. Use hand pressure only. Do not use a wrench to force the shaft.

The shaft should be immovable. Remove the cover, coat both sides of the cover gasket and the threads of the attaching cap screws with plastic type gasket cement and install the gasket and the cover. Again attempt to turn the shaft by hand. The shaft should now turn freely; thus proving that the end clearance of the rotors is less than **0.004-inch** (the thickness of the gasket when compressed) which is satisfactory.

c. If the shaft can be turned when the cover but not the gasket is installed, try a new body cover, body, or both until the proper end clearance is attained.

d. Install the oil pump drive gear (G) on the end of the shaft, tapping it toward the oil pump body until the pin hole in the gear is aligned with the pin hole in the shaft. Insert the drive gear pin (J) about half way into pin hole.

Note. If a new inner rotor with shaft is being installed, refer to e below.

- A—SCREW, CAP, LOCK WASHER, 1/4-20NC-2 X 5/8-180018
- B —COVER, BODY-7744332
- C —GASKET, COVER-7744324
- D —ROTOR, OUTER — WO 641483
- E —ROTOR, INNER, W/SHAFT, ASSY — WO 641742
- F -- BODY, W BEARING WO - 801761
- G —GEAR, DRIVE-7744333
- H —GASKET, OIL PUMP TO CYLINDER BLOCK-7372587
- J —PIN, DRIVE GEAR-7371279
- K —RETAINER, PRESSURE RELIEF VALVE SPRING-7371 271
- I. —GASKET, PRESSURE RELIEF VALVE SPRING RETAINER-7371 270
- M**—**SHIM**, PRESSURE RELIEF VALVE SPRING-7371268
- N—SPRING, PRESSURE RELIEF VALVE-7372586
- P—VALVE, PRESSURE RELIEF-7371 275

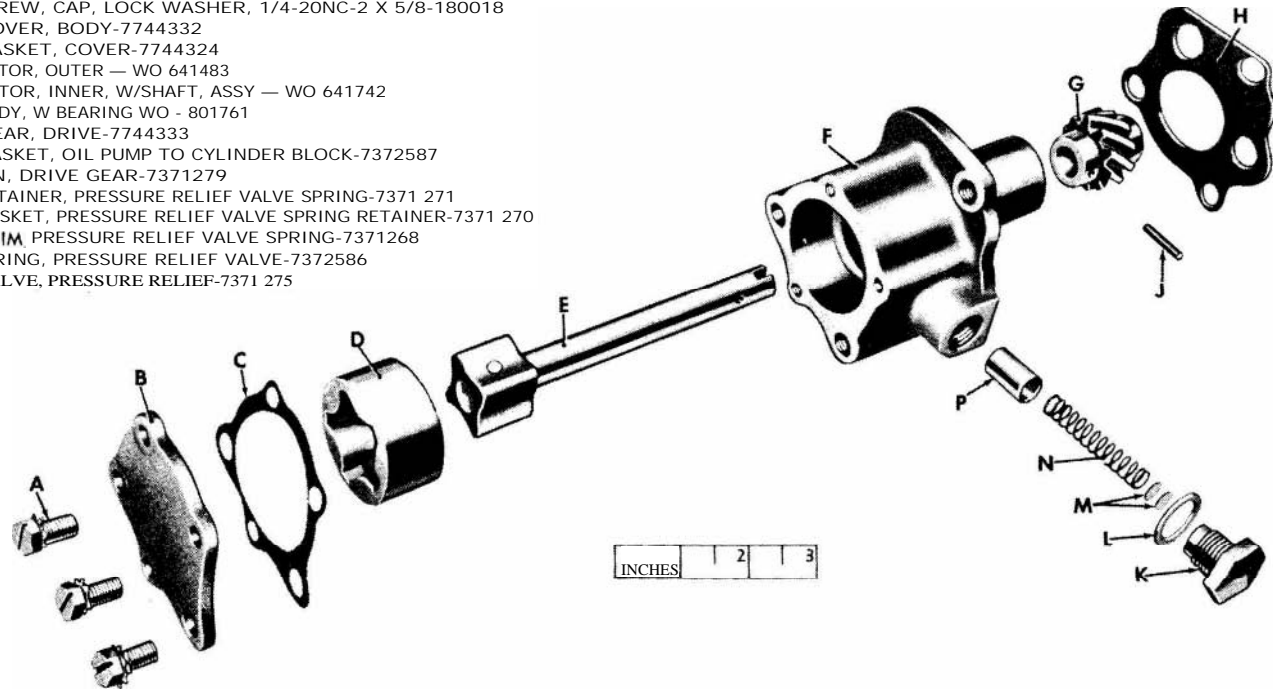

NOTE KIT, REPAIR, OIL PUMP-7744329
 IS COMPOSED OF PARTS C, D, E, G, J, AND L

RA PD 181074

Figure 63. Oil pump *assembly—disassembled* view.

Check the clearance between the inner edge of the gear and the end of the body using a feeler gage. There should be from 0.020 to 0.030-inch clearance at this point. If the clearance exceeds the maximum of 0.030-inch, replace the gear or the body with bearing, whichever part is worn. When the correct clearance is attained, tap the drive gear pin completely through the shaft and the gear, and peen the ends to secure the pin in place.

e. If a new inner rotor with shaft is being used, install the gear and tap it forward toward the oil pump body until there is only 0.020 to 0.030-inch clearance between the end of the body and the face of the gear. Clamp the gear and the shaft in this position, and using the hole in the gear as a guide for the drill, drill a $\frac{5}{32}$ -inch hole through the shaft. Install a new drive gear pin through the gear and shaft and peen the ends to secure it in place.

f. Install the oil pressure relief valve (P), the pressure relief valve spring (N), the pressure relief valve spring shim or shims (M), a new pressure relief valve spring retainer gasket (L), and the pressure relief valve spring retainer (K) in the opening in the side of the oil pump body. Install shims in accordance with paragraph 78b(8).

Section XV. REBUILD OF ENGINE REAR MOUNTING PLATE

80. Disassembly

(fig. 64)

Remove the four socket-head cap screws and copper gaskets securing the rear mounting plate support to the rear mounting plate and remove the support.

81. Cleaning, Inspection, and Repair

Note. Before performing any of the operations given in this section, refer to the general instructions given in paragraphs 24 through 29, relative to the cleaning, inspection, and repair of engine parts.

a. *Claming.* Clean the rear mounting plate and the support.

b. *Inspection and Repair.*

- (1) Replace the rear mounting plate if any of the mounting holes are elongated, or if the plate is bent or warped.
- (2) Check the tapped holes in the reinforcing bars and square nuts welded to the mounting plate, running a tap through them, if necessary to clean any rough or damaged threads.
- (3) Examine the rear mounting plate support and replace if the rubber, originally bonded to the support, has become loosened or has deteriorated.
- (4) Replace the copper gaskets.

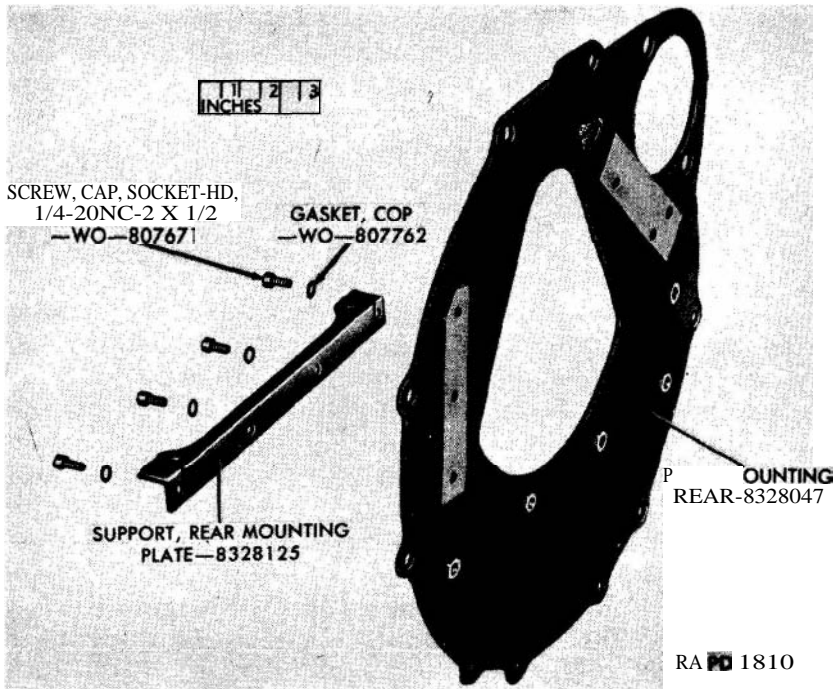

Figure 64. Rear mounting plate **assembly—disassembled** view.

82. Assembly

(fig. 64)

Assemble the rear mounting plate support with the engine rear mounting plate using the new copper gaskets under the heads of the four $\frac{1}{4}$ -20NC-2 x $\frac{1}{2}$ socket-head cap screws. Tighten the cap screws only finger tight at this time.

Section XVI. REBUILD OF TIMING GEAR COVER ASSEMBLY

83. Disassembly

(fig. 65)

Press or drive the crankshaft front oil seal out of the timing gear cover.

84. Cleaning, Inspection, and Repair

Note. Before performing any of the operations given in this section, refer to the general instructions given in paragraphs 24 through 29, relative to the cleaning, inspection, and repair of engine parts.

a. *Cleaning.* Clean the timing gear cover.

1. *Inspection and Repair.*

(1) Replace the crankshaft front oil seal.

- (2) Replace the cover if the cover is dented or warped out of shape.
- (3) Examine the bolting flange of the cover for distortion or stretching of the metal around the attaching bolt holes. If necessary, smooth out the rough areas of the flange following the procedures given in paragraph 89b and shown in figure 69.

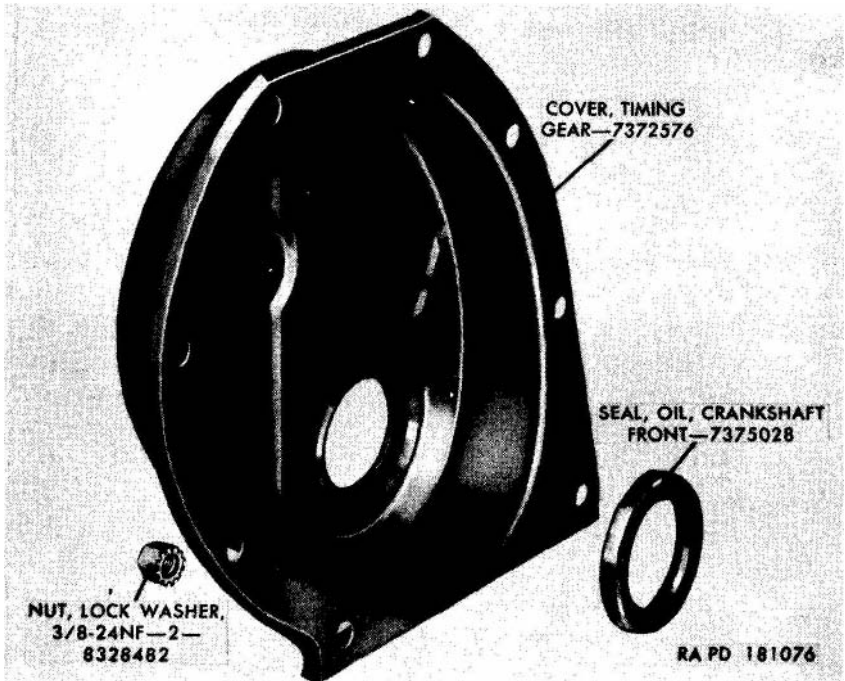

Figure 65. Timing gear cover—*disassembled* view.

85. Assembly

(fig. 65)

Press the crankshaft front oil seal into the timing gear cover with the protruding leather edge of the seal facing the rear of the cover.

Section XVII. INSPECTION, REPAIR, AND REBUILD OF ASSOCIATED PARTS

86. Cleaning, Inspection, and Repair

Before performing any of the operations given in this section, refer to the general instructions given in paragraphs 24 through 29 relative to the cleaning, inspection, and repair of engine parts.

87. Exhaust Valves and Related Parts

a. *Cleaning.* Perform the same cleaning operations on the exhaust valves and their related parts as were performed on the intake valves and their related parts (par. 54a).

b. *Inspection.*

(1) *Exhaust valves.* Make the same inspection checks on the exhaust valves as were made on the intake valves (par. 54b (2)).

(2) *Exhaust valve springs.* Make the same inspection checks on the exhaust valve springs as were made on the intake valve springs (par. 54b (3)) The test standards for the exhaust valve springs are as follows : Free length to be not less than **2½-inches**. Compression pressure to be not less than 50-psi when compressed to 2 $\frac{3}{4}$ -inch ; nor less than 116-psi when compressed to **1¾-inch** (fig. 35).

Note. Exhaust and intake valve springs may look alike but are different. They must not be interchanged.

(3) *Exhaust valve spring retainers, spring retainer locks, and rotor caps.* Inspect the parts for evidence of uneven wear and obvious damage or faults. If one valve spring retainer lock of a valve is damaged or worn, both locks of the valve must be replaced.

c. *Repair.*

(1) *Exhaust valves.*

(a) Using a valve refacing tool, grind the seat area of the exhaust valves to an angle of 45°. Remove only enough metal to clean the seat and eliminate pitted or burned areas. If it is necessary to remove so much metal from the face of the valve that the thickness of the edge of the valve head is reduced to less than **⅓₂-inch**, replace the valve. Replace any valves with bent stems, or valves which do not conform to the repair and rebuild standards (par. 150a).

Note. If the stem of a valve is bent, it will be apparent when the valve is clamped in the refacing machine. Discard such valves and replace with new ones.

(b) Lap the exhaust valves in the exhaust valve seats in the cylinder block as instructed in paragraph 51b(6).

(2) *Check exhaust valve to rotator cap clearance.*

(a) The rotator cap used between the exhaust valve adjusting screw and the end of the exhaust valve provides the means whereby the exhaust valve is momentarily freed and allowed to rotate slightly each time it is lifted off its seat

in the cylinder block. In order for the parts to operate in their intended manner, there must be at least 0.000- to 0.004-inch (fig. 66) clearance between the end of the exhaust valve and the rotator cap.

(b) Check the exhaust valve to exhaust valve rotator cap clearance using kit 41-K-84-15 (fig. 66).

1. Stand the exhaust valve upright on the valve head. Lower the collar 41-C-2482-15 (fig. 66) over the valve stem

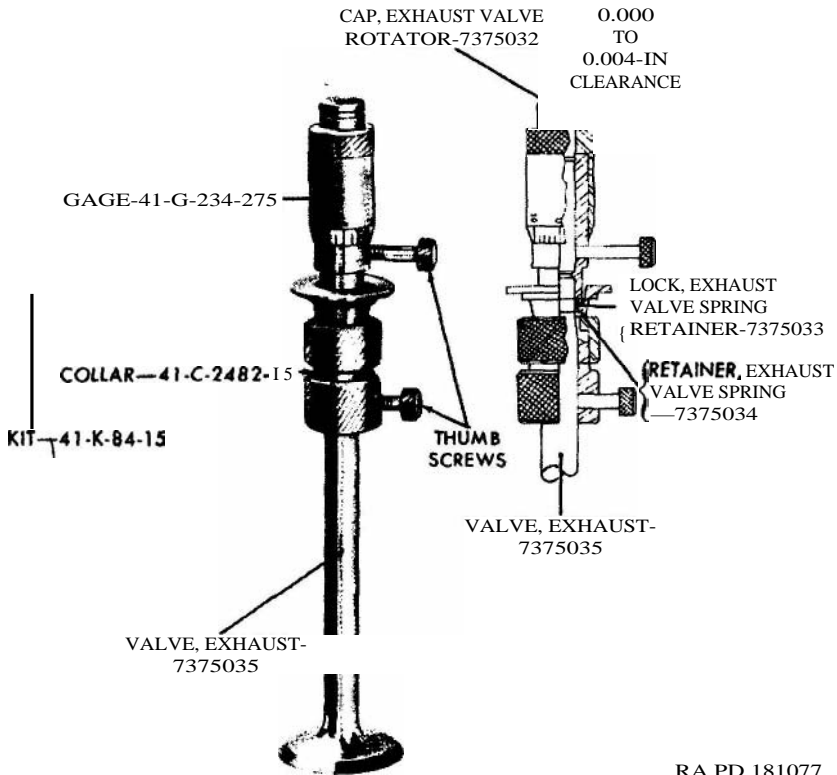

RA PD 181077

Figure 66. Kit-41-K-84-15 in position on exhaust valve.

and install the exhaust valve spring retainer and retainer locks on the end of the valve. Slide the collar up against the spring retainer, and lock the collar in this position by tightening the collar thumb screw. Turn the upper half of the collar to the right as far as possible to take up any slack remaining between the assembled parts.

2. Adjust the thimble of gage 41-G-234-275 so that the "0" mark on the thimble is alined with the mark scribed along

the length of the body of the gage. Loosen the **gage** thumb screw and set the gage over the end of the valve with the lower edge of the gage resting on the valve spring retainer locks. Press down on top of the gage center pin and tighten the gage thumb screw.

3. Set the exhaust valve rotator cap on top of the gage with the end of the gage center pin entered in the hole in the cap. While holding the assembled parts cradled in one hand, and pressing on the top of the exhaust valve rotator

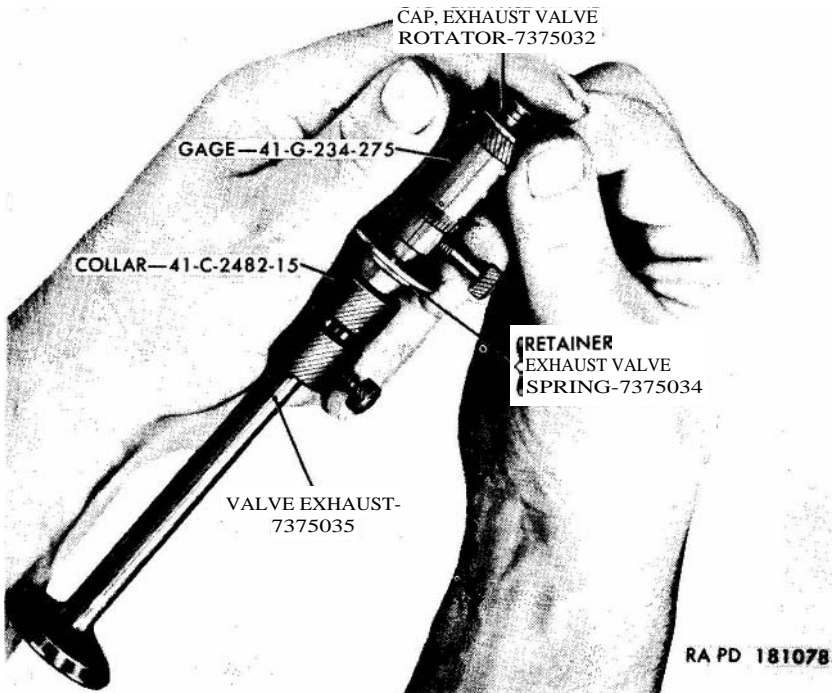

Figure 67. Checking **exhaust** valve to rotator cap clearance with **kit-41-K-84-15**.

cap (fig. 67) with one finger, turn the gage thimble one complete revolution to the left. Slowly turn the thimble back to the right until the top of the thimble contacts the lower edge of the rotator cap and note the reading opposite the scribe mark on the body of the gage.

4. A reading in excess of 0.004 inch to the right of the "0" mark indicates that there is too much clearance. To reduce the clearance, grind or lap the rim of the rotator cap as necessary to bring the clearance within the specified limits. A reading of any amount to the left of the "0" mark indicates that there is not enough clearance.

To increase the clearance, grind or lap the end of the exhaust valve *as* necessary to bring the clearance up to the specified *limits*.

5. When the correct clearance is attained, remove the gage and collar from the valve and keep the valve, the rotator cap, the retainer lock and the retainer together until the specified limits.

Note. After the valve and its related parts are checked with kit 41-K-84-15, they are considered to be mated parts. If intermixing with other valve parts accidentally occurs, check the affected parts again.

- A—STUD, 3/8-24NF-3—WO-300143
- B—GASKET, EXHAUST MANIFOLD, END
—WO-648795
- C—NUT, SELF-LOCKING, 3/8-24NF-3—503354

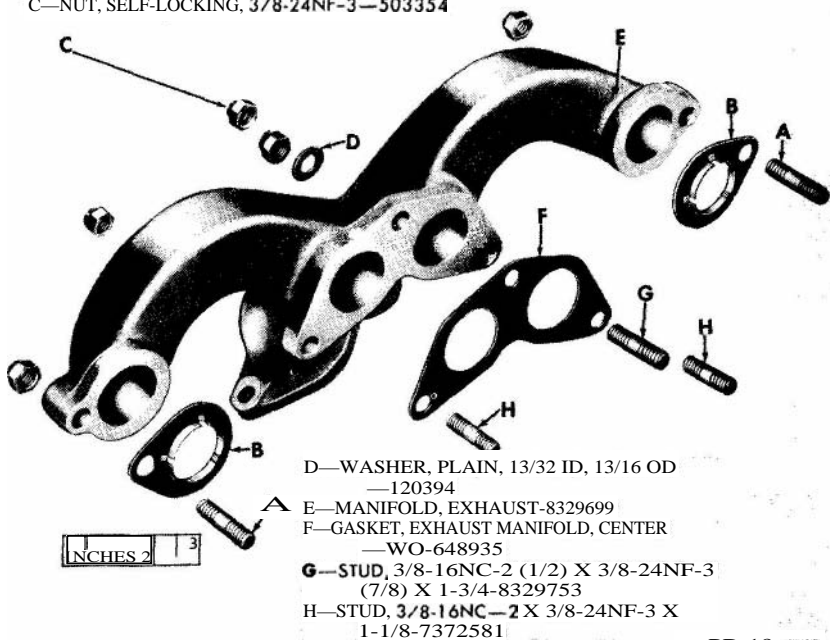

RA PD 18 079

Figure 68. Exhaust manifold and attaching parts.

88. Exhaust Manifold

a. Inspection. Replace the exhaust manifold (fig. 68) if broken or cracked. Check for cracks particularly around the mounting holes and exhaust ports. Lay manifold on flat surface and check alinement of gasket surfaces. If manifold is broken, cracked or warped, it must be replaced.

b. Repair. No repairs to the exhaust manifold are possible, replace if it is broken or damaged.

89. Oil Pan

a. *Disassembly and Assembly.* Remove the oil pan drain plug (fig. 69) from the side of the oil pan. Replace the oil pan drain plug gasket. Install the $\frac{7}{8}$ -inch drain plug.

b. *Repair.* Inspect the bolting flange of the oil pan for distortion or stretching of the metal around the attaching bolt holes. If such faults are present, clamp a piece of bar stock approximately $1\frac{1}{4} \times 716 \times$

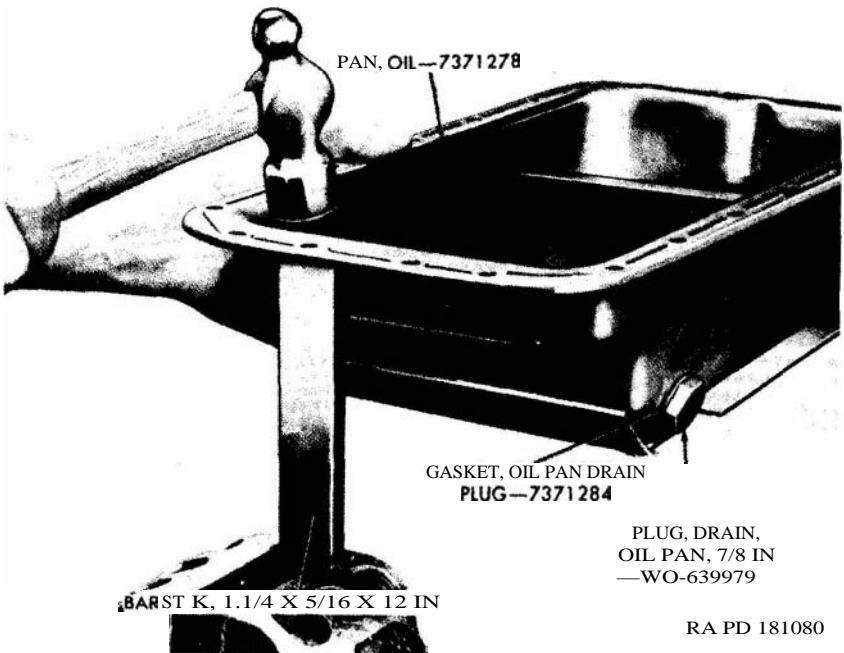

Figure 69. Straightening bolting flange of oil pan.

$1\frac{1}{2}$ (fig. 69) in a bench vise and, using the bar stock as an anvil, flatten any distorted areas to a smooth level surface. Replace the oil pan if it is deeply dented, distorted, or out of shape.

90. Timing Gears (Crankshaft Drive and Camshaft Driven Gears)

Always replace the camshaft driven gear. The driven gear is fibre and the crankshaft drive gear is steel. Because of this difference in materials, the driven gear absorbs whatever wear occurs between the gears and is usually the only one of the two that requires replacement. However, if inspection reveals the crankshaft drive gear to be damaged, or if the woodruff key slot in the bore of the gear is distorted or mis-shapen, replace the drive gear also.

91. Fan Belts

Unless the fan belts are in exceptionally good condition, replace *both* fan belts.

92. Front Mounting Support Cushion

Replace the engine front mounting support cushions if the rubber has become loosened from the steel plates to which it was originally bonded, or if the rubber has deteriorated and has become soft and spongy.

93. Miscellaneous and Standard Parts

All other engine parts not specifically covered in the above rebuild sections must be individually cleaned and inspected and judged as to their fitness for further use. Unless a part, no matter how small or minor, can be repaired or reworked so that it is restored to its original size or shape it must be replaced. Standard parts, such as bolts or cap screws, on which the corners have been rounded, or the threads roughened, or flattened, must be replaced.

Section XVIII. ASSEMBLY OF ENGINE FROM SUBASSEMBLIES

94. Install Intake and Exhaust Valve Tappets and Camshaft

(figs. 70 and 71)

- a. Mount the cylinder block in an engine repair stand (par. 30).

Note. If an engine repair stand is not available, perform the following assembly operations in a manner designed to protect the engine or engine parts against damage and personnel against injury.

- b. Turn the engine upside down so that the bottom of the engine is facing up. Beginning at the rear end of the cylinder block, install the intake and exhaust valve tappets in the tappet bores in the cylinder block in the following order : One exhaust valve tappet, two intake valve tappets, two exhaust valve tappets, two intake valve tappets and one exhaust valve tappet.

- c. Carefully, so as not to damage or score the camshaft front bearing, insert the camshaft into the camshaft bore of the cylinder block.

Note. Do not allow the rear end of the camshaft to strike sharply against the expansion plug (fig. 27) installed in the rear end of the bore.

- d. Install the camshaft thrust plate (fig. 24) on the front end of the cylinder block and secure in place with two $\frac{1}{2}$ -16NC-2 x $\frac{3}{4}$ lock washer cap screws. Tighten the cap screws to a torque of 20 to 26 pound-feet. Slide the camshaft thrust plate spacer onto the end of the camshaft with the beveled inner edge of the spacer facing the cylinder block.

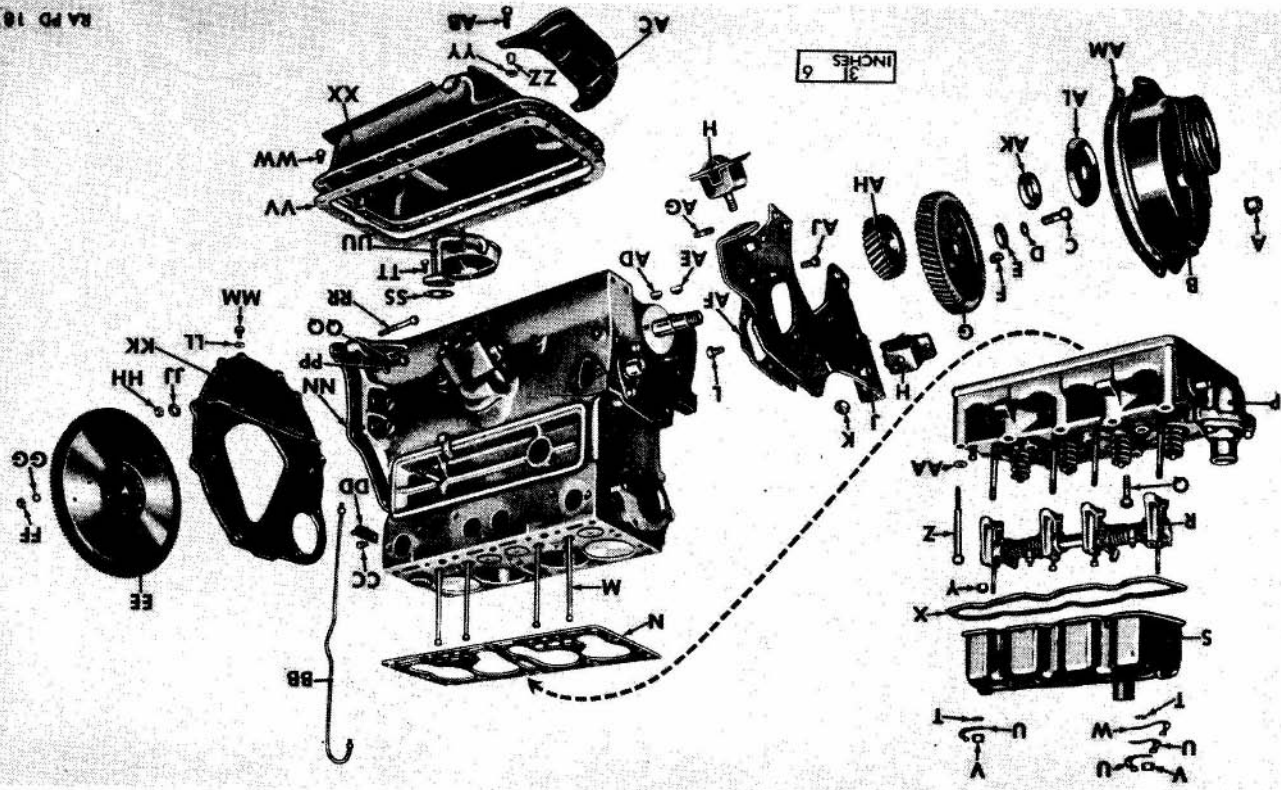

A—Nut, lock washer, $\frac{3}{8}$ -24NF-2-8328482
B—Cover, timing gear-7372576
C—Screw, cap, $\frac{1}{4}$ -14NC-3 x $1\frac{1}{2}$ -122260
D—Washer, lock, ext-teeth, $\frac{1}{16}$ -inch-136857
E—Washer, plain-7741404
F—Key, woodruff, $\frac{3}{16}$ x %-124549
G—Gear, camshaft driven-7741419
H—Cushion, front mounting support-8328391
J—Plate, front mounting-7372578
K—Nut, "huglock", $\frac{1}{2}$ -20NF-2B-442832
L—Bolt, $\frac{3}{8}$ -24NF-3 x $\frac{3}{4}$ -WO-123520
M—Rod, push, intake valve-8329717
N—Gasket, cylinder head-8328463
P—Head, cylinder, assy (see fig. 39)
Q—Screw, cap, $\frac{1}{4}$ -14NC-2 x $1\frac{1}{4}$ -8328474
R—Arm, rocker, assy (see fig. 39)
S—Cover, rocker arm-8329713
T—Gasket, rocker arm cover stud—WO-51875
U—Clip, spark plug cable—WO-8072010
V—Nut, $\frac{1}{4}$ -24NF-2-120868
W—Clip, spark plug cable—WO-8072020
X—Gasket, rocker arm cover-8329716
Y—Nut, lock, %-24-7744472
Z—Screw, cap, $\frac{1}{4}$ -14NC-2 x 41,4--8329677
AA—Washer, plain-8329680
BB—Line, oil, crankcase to cylinder head, assy-8328408
CC—Screw, cap, lock washer, $\frac{1}{4}$ -20NC-2 x %—WO-800226
DD—Clip, $\frac{3}{16}$ -inch—WO-645539
BE—Flywheel, assy-8328045
FF—Nut, %-24NF-2-120369
GG—Washer, lock, ext-teeth, %-inch-138489
HH—Nut, $\frac{3}{8}$ -24NF-2-120369
JJ—Washer, lock, %-inch-138489
KK—Plate, rear mounting-8328047
LL—Gasket, special—A226080
MM—Screw, cap, $\frac{1}{16}$ -18NC-3 x $\frac{3}{4}$ -122007
NN—Gasket, cylinder block to rear mounting plate-8328049
PP—Gasket, special—A226080
QQ—Screw, cap, $\frac{3}{16}$ -24NF-3 x %-120213
RR—Bolt, $\frac{3}{8}$ -24NF-2 x 3%-7371700
SS—Gasket, oil strainer support-7371267
TT—Screw, cap, lock washer, $\frac{3}{16}$ -18NC-3 x %-451975
UU—Strainer, oil, assy-7036578
VV—Gasket, oil pan—WO-639980
WW—Screw, cap, lock washer, $\frac{3}{16}$ -18NC-2 x %-8328411
XX—Pan, oil-7371278
YY—Gasket, spacer, pulley shield—WO-6701
ZZ—Spacer, fan and drive pulley shield-7372559
AB—Screw, cap, lock washer, $\frac{3}{16}$ -18NC-2 x $1\frac{1}{8}$ -423563
AC—Shield, fan and generator drive pulley—7371376
AD—Key, woodruff, $\frac{3}{16}$ x 1-124552
AE—Key, woodruff, $\frac{3}{16}$ x %-124549
AF—Gasket, cylinder block to mounting plate-7741427
AG—Stud, $\frac{3}{8}$ -18NC-2 ($\frac{3}{16}$) x $\frac{3}{8}$ -24NF-2 (%) x $1\frac{1}{16}$ -103197
AH—Gear, crankshaft drive-7741415
AJ—Screw, cap, lock washer, %-24NF-3 x %-123520
AK—Spacer, camshaft drive gear-7741414
AL—Slinger, oil, crankshaft-7371161
AM—Gasket, timing gear cover-7371159

Figure 70. Engine assembly—disassembled view No. 1.

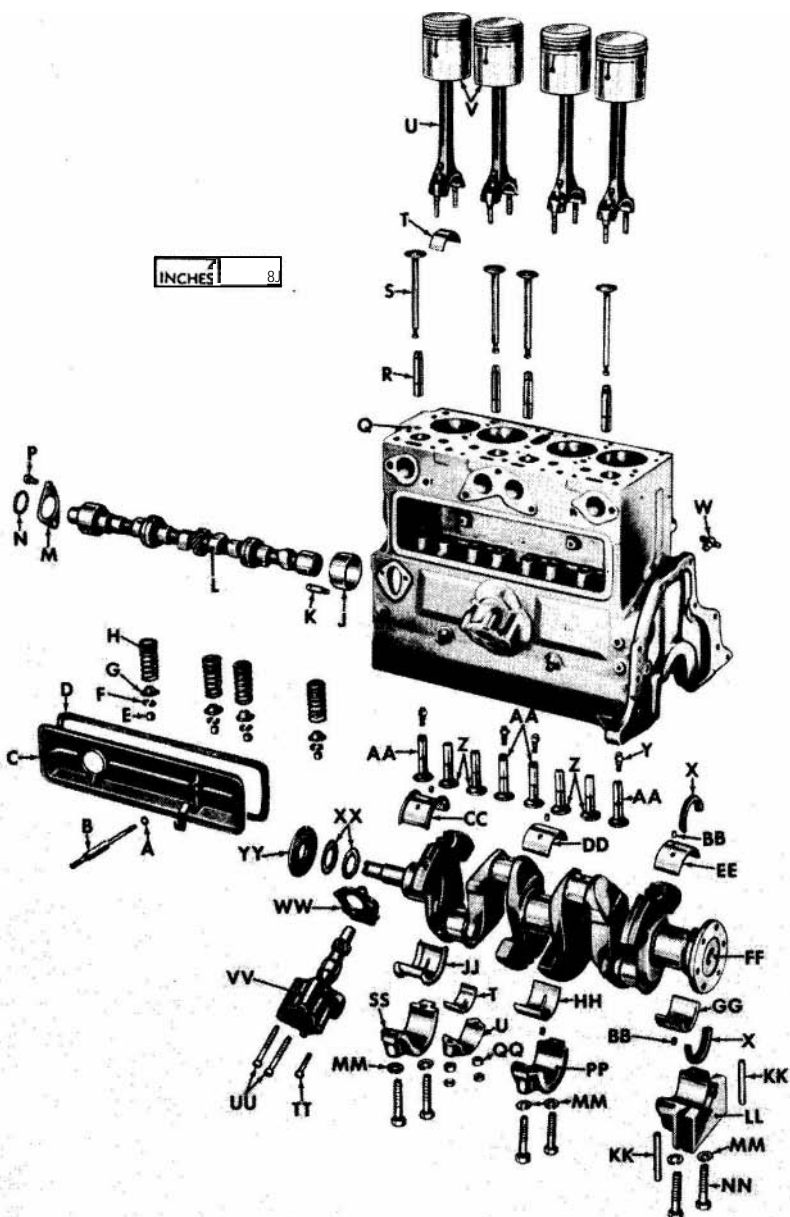

RA PD 181082

Figure 71. Engine assembly—disassembled view No. Z.

95. Install Main Bearing Halves in Cylinder Block

(fig. 72)

a. Install one half of the rear bearing oil seal in the seal groove in the rear end of the cylinder block.

b. Install the bearing dowel pins in the bearing dowel pin holes in the cylinder block, making sure the pins are installed with the small diameter projecting into the bore.

c. Install the main bearing halves in the cylinder block as follows :

- (1) Install the bearing half with the double oil groove and the flanged sides in the front bearing support.

A—Gasket, exhaust valve spring compartment cover stud—WO-51875	AA—Tappet, exhaust valve-7372585
B—Stud, exhaust valve spring compartment cover-806348	BB—Pin, dowel, bearing-7371229
C—Cover, exhaust valve spring compartment-7371237	CC—Bearing, half, front, main-7371167
D—Gasket, valve spring compartment cover—WO-630305	DD—Bearing, half, center, main-7371173
E—Cap, rotor, exhaust valve-7375023	EE—Bearing, half, rear, main-7371165
F—Lock, exhaust valve spring retainer-7375033	FF—Crankshaft-7744473
G—Retainer, exhaust valve spring-7375034	GG—Bearing, half, rear, main-7371169
H—Spring, exhaust valve-7371235	HH—Bearing, half, center, main-7371225
J—Bearing, bushing type, camshaft front-7744319	JJ—Bearing, half, front, main-7371171
K—Jet, oil, timing gear-7372557	KK—Packing, rear bearing cap-7371281
L—Camshaft-8329698	LL—Cap, main bearing, rear—WO-737236
M—Plate, camshaft thrust-7351413	MM—Washer, lock, in.-120384
N—Spacer, camshaft thrust plate-7741407	NN—Screw, cap, main bearing cap-7371227
P—Screw, cap, lock washer, $\frac{5}{8}$ -16NC-2 x 3/4-423569	PP—Cap, main bearing, center—WO-630288
Q—Block, cylinder, assy-7412658	QQ—Nut, %-24NF-3-7744472
R—Guide, exhaust valve-8328126	RR—Nut, jam, %-24-107823
S—Valve, exhaust-7375035	SS—Cap, main bearing, front—WO-630285
T—Bearing, half, connecting rod-5701528	TT—Screw, cap, lock washer, $\frac{5}{16}$ -18NC-3 x 1-122017
U—Rod, connecting-7743751	UU—Screw, cap, lock washer, $\frac{5}{16}$ -18NC-3 x 2 $\frac{1}{2}$ -8328399
V—Piston, w/pin, assy-7373873	VV—Pump, oil, assy—7376907
W—Cock, tee handle, drain-103647	WW—Gasket, oil pump to cylinder block-7372587
X—Seal, oil, crankshaft rear bearing-7372560	XX—Shim, adjusting crankshaft end play, 0.002 thk—7371226
Y—Screw, adjusting, exhaust valve-7371258	YY—Washer, thrust, crankshaft-7371160
Z—Tappet, intake valve—WO-800550	

Figure 71.—Continued

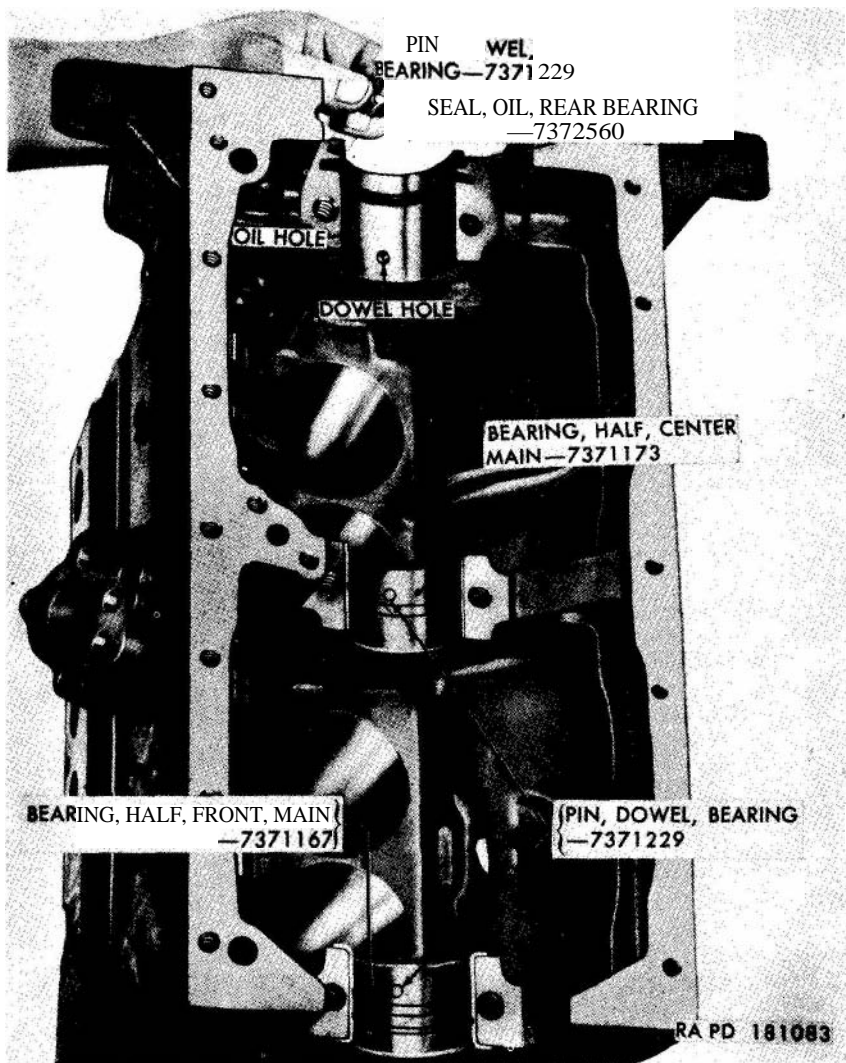

Figure 72. Installing crankshaft bearings and dowel pins.

- (2) Install the bearing half with the single oil groove in the center support.
- (3) Install the bearing half with the double oil grooves and non-flanged sides in the rear support.

Note. Spread a light coat of engine oil over the entire surface of the bearing halves.

96. Install Crankshaft and Main Bearing Caps

a. If the flywheel is being replaced, drill and ream the dowel pin holes in the crankshaft flywheel mounting flange as instructed in paragraph 700(2).

b. Stand the crankshaft upright on the rear (flanged) end on a clean solid surface. Install three 0.002-inch crankshaft end play adjusting shims (fig. 73) and the crankshaft thrust washer on the front end of the crankshaft. Install the thrust washer so that the inner beveled edge faces the rear end of the crankshaft.

Note. The installation of the 0.006-inch shim thickness facilitates the subsequent adjustment of the crankshaft end play (par. 107).

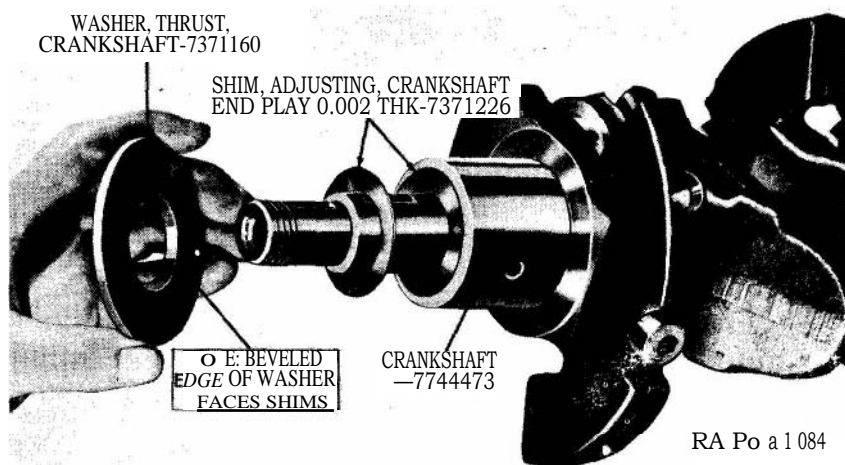

Figure 73. Crankshaft end play adjusting shims and thrust washer.

c. Install the $\frac{3}{18} \times 1$ crankshaft drive gear woodruff key (fig. 78) in the longer of the two key slots on the front end of the crankshaft. Install the crankshaft drive gear on the front end of the crankshaft with the timing mark "0" facing out, away from the cylinder block. Aline the keyway in the gear, with the key installed in the shaft, and drive or press the gear onto the crankshaft and firmly against the thrust washer.

d. Insert the four $\frac{3}{8}$ -24NF-2 x flywheel bolts and the two tapered dowels (fig. 52) in the flywheel bolt holes in the flange on the rear of the crankshaft.

Note. If flywheel or crankshaft has been replaced and flywheel and crankshaft holes have been bored and reamed, use dowel bolts in place of tapered dowels.

e. Carefully lower the crankshaft onto the bearings in the cylinder block.

f. Assemble main bearing halves in the main bearing caps as follows :

- (1) Insert the other half of the rear bearing oil seal (*fig. 74*), a bearing dowel pin with the small diameter projecting into the bore, and the other half of the rear main bearing in the rear main bearing cap. Note that both halves of the rear main bearing have double oil grooves and non-flanged sides.



Figure 74. Installing main bearing halves in main bearing caps.

- (2) Insert a bearing dowel pin, with the small diameter of the pin projecting into the bore, and the other half of the center main bearing into the center main bearing cap. Note that both halves of the center main bearing have a single oil groove and non-flanged sides.
- (3) Insert the other half of the front main bearing into the front main bearing cap. Note that no dowel pin is used in

this cap. Also note that the bearing has flanged sides and a double oil groove.

Note. Because it is possible to incorrectly install this bearing, take particular care to see that the bearing is installed in the cap with the narrower of the two oil grooves nearer the front edge of the cap. If this bearing is not properly installed, the oil grooves in the two halves of the bearing will not match at the parting line and will cause the premature failure of the bearing.

g. Lightly coat both ends of both halves of the rear bearing oil seal and both sides of the crankshaft rear main bearing cap (fig. 74) with plastic type gasket cement and install the bearing cap in the cylinder block. Coat both pieces of the rear bearing cap with plastic type gasket cement and insert the packing into the holes on

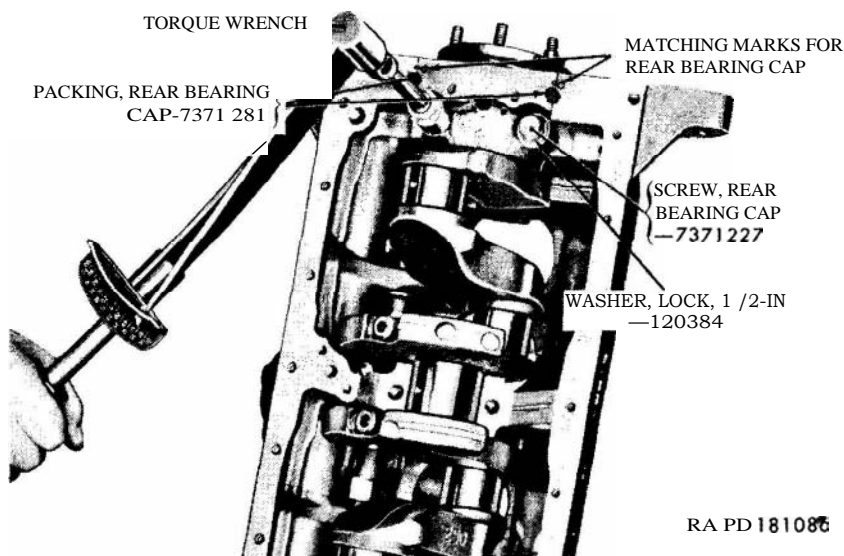

Figure 75. Installing rear bearing cap.

either side of the rear bearing cap (fig. 75). The ends of the packing should protrude approximately one-fourth of an inch. Do not cut them off because when the oil pan is installed, it forces the packing further into the holes to effectively seal this area against oil leaks.

h. Secure the rear bearing cap in place with two $\frac{1}{2}$ -inch lockwashers (fig. 75) and two rear bearing cap screws. Tap the bearing cap to align the matching marks on the bearing cap with those on the cylinder block. Tighten the cap screws to 65 to 70 pound-feet torque.

97. Check Running Clearance of Main Bearings

a. Thread the $1\frac{1}{16}$ -inch nut (fig. 17) onto the front end of the crankshaft. Using a socket wrench fitted over the nut as a crank,

check the clearance between the main bearings and the **crankshaft** as follows:

- (1) *Check for insufficient main bearing clearance.* With the rear bearing cap tightened to the specified torque (par. 96h) , and using hand pressure only, turn the crankshaft through two complete revolutions. The crankshaft should turn freely without effort. If the crankshaft is immovable or if force is required to turn it, the bearing is too thick and must be replaced. In this event remove the cap and both halves of the bearing, and measure the dimensions of the journal to determine the bearing size required. Install a new bearing (both halves) and recheck as above.

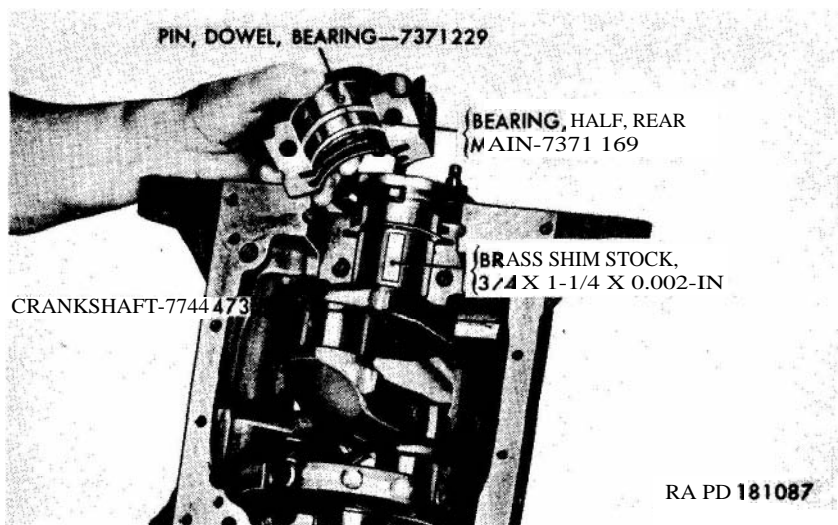

Figure 76. Checking rear main bearing for underSize.

- (2) *Check for excessive main bearing clearance.* If the crankshaft turns freely, remove the bearing cap with its half bearing. Cut a piece of brass shim stock $\frac{3}{4}$ -inch wide, $1\frac{1}{4}$ -inches long, and 0.002 thick (fig. 76).

Note. After cutting the shim stock, feather the edges on a honing stone to avoid the possibility of a rough edge scratching the surface of the bearing.

Lay the piece of shim stock on the crankshaft bearing journal and replace the cap and half bearing. Install the lock washers and the cap screws and tighten the screws to 65 to 70 pound-feet of torque. Again attempt to turn the crankshaft. The crankshaft should now turn with a noticeable dragging action. If the crankshaft turns freely and without effort, the bearing is too thin and must be replaced. In this event.

remove the cap and bearing (both halves) and measure the dimensions of the journal to determine the size of bearing required. Install the new bearing (both halves) and the cap and recheck as above.

Note. Do not fail to remove the shim stock upon completion of the above operation.

b. Install the center and front main bearings repeating operation a(1) and (2) above on each bearing.

Note. It is essential for the flanged sides of both halves of the front main bearing to be in perfect alignment when the front main bearing cap is tightened for the last time after completion of operations a(1) and (2) above. Aline these surfaces by using a screwdriver or other suitable pry-bar (fig. 87) to force the crankshaft forward so the thrust face (fig. 74) of the crankshaft held firmly against the flanged edge of the upper half of the front main bearing. Install and tighten the front main bearing cap, lightly tapping the cap backward to force the flanged side of the bearing against the thrust face of the crankshaft as the cap tightening operation progresses.

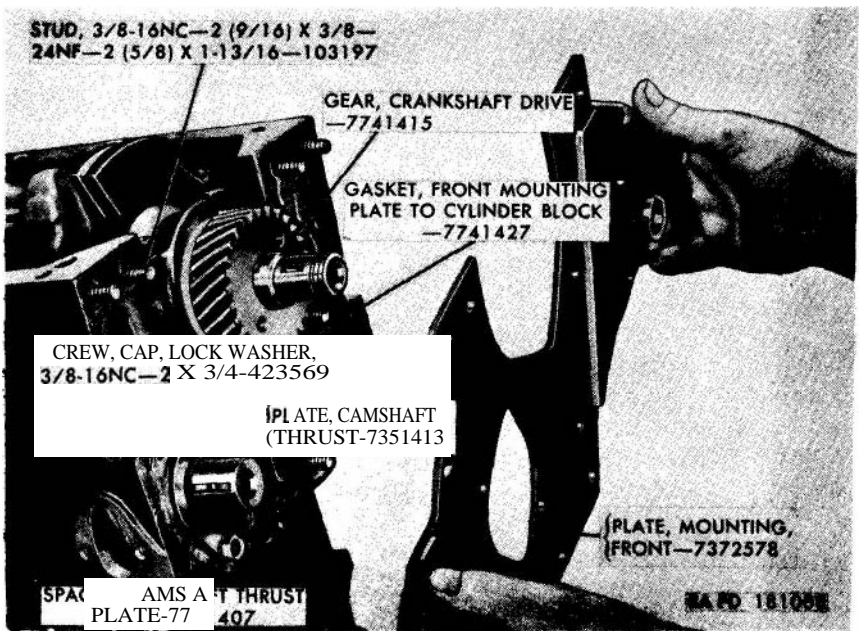

Figure 77. Installing front mounting plate.

98. Install Front Mounting Plate

a. Coat the threads of the six $\frac{3}{8}$ -16NC-2 ($\frac{5}{16}$) x $\frac{3}{8}$ -24NF-2 ($\frac{5}{8}$) x $1\frac{1}{16}$ studs (fig. 77), used to secure the mounting plate and timing gear cover to the front end of the cylinder block, with plastic type gasket cement. Install the studs in the front end of the cylinder block.

b. Coat both sides of the mounting plate to cylinder block gasket with liquid type gasket cement and install the gasket over the mounting plate studs. Install the front mounting plate and secure in place with two $\frac{3}{8}$ -24NF-2 lock washer nuts (fig. 78) and three $\frac{3}{8}$ -16NC-3 x $\frac{3}{4}$ lock washer cap screws. Coat the threads of cap screws with plastic type gasket cement before installing.

99. Install Camshaft Driven Gear

a. Install the $\frac{3}{16}$ x $\frac{3}{4}$ camshaft driven gear woodruff key (fig. 78) in the key slot in front end of the camshaft.

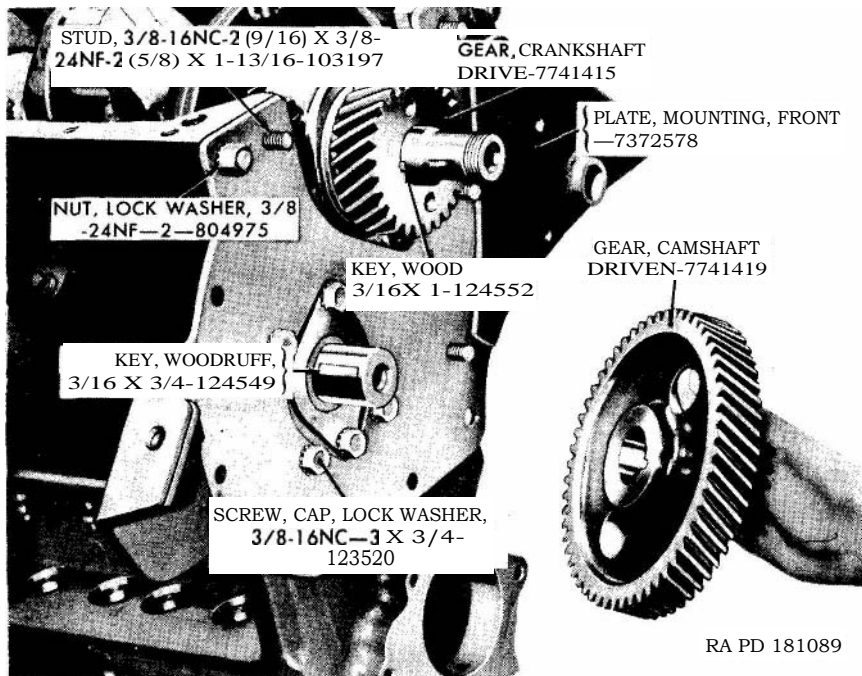

Figure 78. Installing camshaft driven gear.

b. With the woodruff key in the camshaft and the key slot in the camshaft driven gear (fig. 78) in alignment, start the camshaft driven gear onto the camshaft with the wide hub of the gear facing out, away from the cylinder block. Turn the camshaft or the crankshaft as necessary to bring the timing marks "0" (figs. 73 and 80) in both gears together. Slide the $\frac{7}{16}$ -inch external teeth lock washer (fig. 79) and the $\frac{1}{2}$ ID x $1\frac{1}{20}$ OD plain washer onto the $\frac{7}{16}$ -14NC-3 x $1\frac{1}{8}$ cap screw and thread the cap screw into the front end of the camshaft. Tighten the cap screw to 30 to 40 pound-feet torque, pressing the gear onto the front end of the camshaft in the process.

Note. Do not drive the gear onto the camshaft.

100. Install Timing Gear Oil Jet

Install the timing gear oil jet (fig. 79) in the tapped hole in front of the cylinder block. Position the oil hole in the side of the oil jet so that it will direct the oil stream against the camshaft driven gear just ahead of the point of its engagement with the crankshaft drive gear.

101. Install Oil Pump Assembly

a. When installing the oil pump assembly the following facts should be borne in mind.

- (1) The oil pump is driven from the camshaft by means of a worm (spiral) gear. The distributor, in turn, is driven by

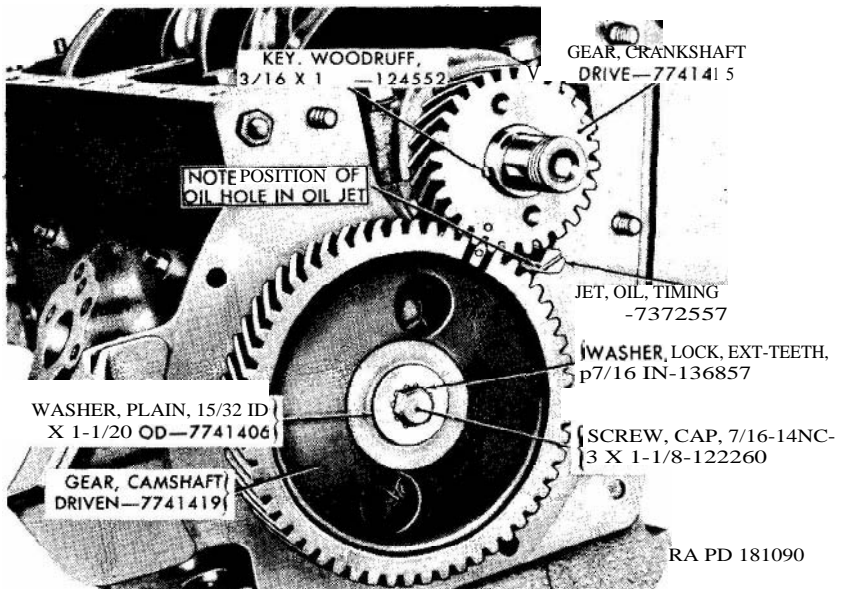

Figure 79. Crankshaft drive and camshaft driven gears (timing gears).

the oil pump by means of a tang on the end of the distributor shaft which engages a slot in the end of the oil pump shaft.

- (2) Because the tang and the slot are both machined off center, the two shafts can be meshed in only one position.
- (3) Since the position of the distributor shaft determines the "timing" of the engine, and since the position of the distributor shaft is determined by the position of the oil pump shaft, the position of the oil pump shaft with respect to the camshaft is critical.

b. Turn the crankshaft as necessary to bring the timing marks "0" on the crankshaft drive and camshaft driven gears together (fig. 79).

c. Coat both sides of the oil pump to cylinder block gasket with liquid type gasket cement and install the gasket on the pump. Start the oil pump drive shaft into the opening in the left side of the cylinder block with the mounting holes in the body of the pump in alignment with the mounting holes in the cylinder block.

d. Insert a long blade screwdriver (fig. 80) into the distributor shaft opening on the opposite side of the block and engage the end of the oil pump shaft. Turn the shaft so that the slot is positioned at what would be the rough equivalent of the nine thirty position on a clock face (fig. 81), with the wider edge of the slot on top (nearer the top of the cylinder block).

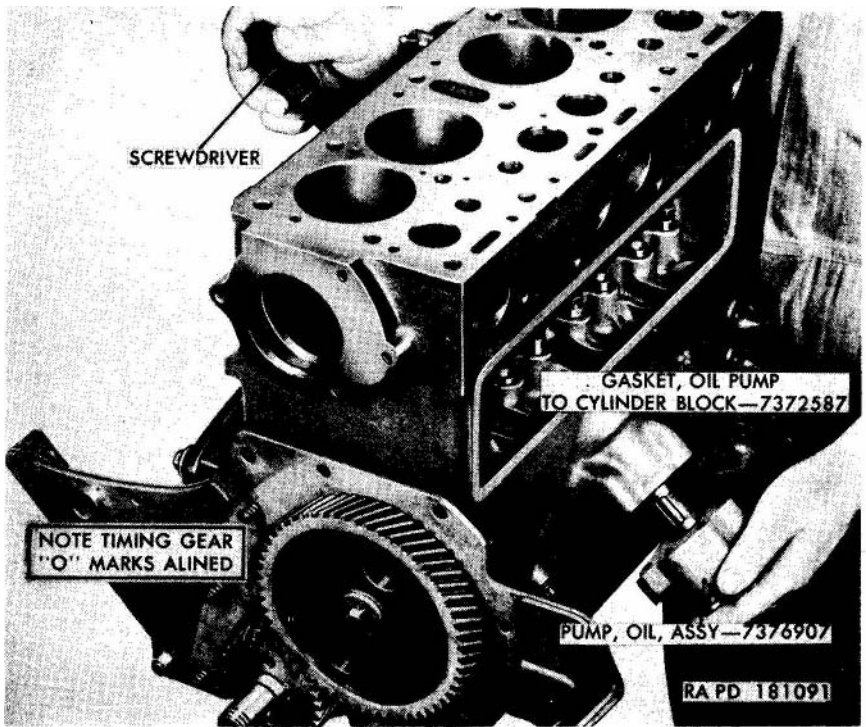

Figure 80. Installing oil pump assembly.

e. Remove the screwdriver and, looking down the distributor shaft hole, observe the position of the slot in the end of the oil pump shaft to make certain it is properly positioned. Replace the screwdriver and, while turning the screwdriver clockwise to guide the oil pump drive shaft gear into engagement with the camshaft spiral gear, press against the oil pump to force it into its final position.

f. Remove the screwdriver and again observe the position of the slot. If the installation was properly made, the slot will be in the position roughly equivalent to the eleven o'clock position on a clock

face (fig. 81) with the wider edge of the slot still on the top side. If the slot is improperly positioned, remove the oil pump assembly and repeat operations *d* and *e* above.

g. Coat the threads of the cap screws with plastic type gasket cement and secure the oil pump in place with two $\frac{5}{16}$ -18NC-3 \times 2 $\frac{1}{2}$ lock washer cap screws (fig. 18) installed through the body of the oil pump and into the cylinder block, and one $\frac{5}{16}$ -18NC-3 \times 1 lock washer cap screw (fig. 18) installed through the oil pump mounting flange and into the cylinder block.

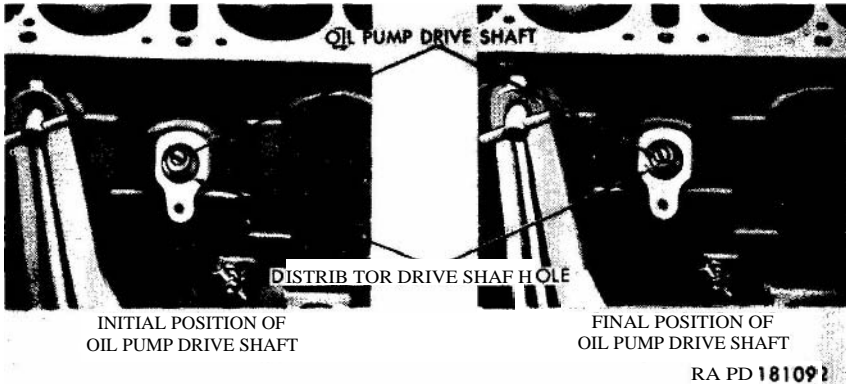

Figure 81. Initial and final positions of oil pump drive shaft.

102. Install Rear Mounting Plate

(fig. 82)

Coat both sides of the rear mounting plate with plastic type gasket cement and install the gasket and the rear mounting plate on the rear end of the cylinder block. Temporarily install loosely one $\frac{9}{16}$ -24NF-2 \times $\frac{7}{8}$ bolt (fig. 21) in each side of the cylinder block to hold the plate in position.

103. Install Flywheel Assembly

(fig. 83)

Install the flywheel assembly on the bolts previously installed in crankshaft mounting flange and secure in place with six $\frac{3}{8}$ -inch external teeth lock washers and $\frac{3}{8}$ -24NF-2 nuts.

Note. To minimize the chances of stripping the bolt threads, tighten the nuts on the two hardened tapered dowel *first*. Tighten all the nuts to 35 to 41 pound-feet torque.

104. Install Pistons and Connecting Rods

a. Install the connecting rod bearing (two halves) in a connecting rod. Spread a light coat of engine oil on the bearing.

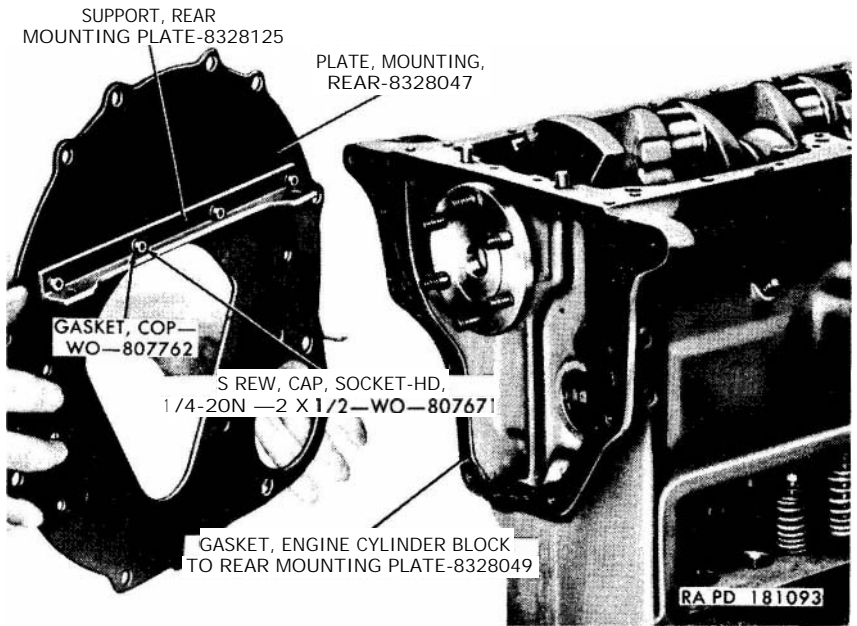

Figure 82. Installing rear mounting plate.

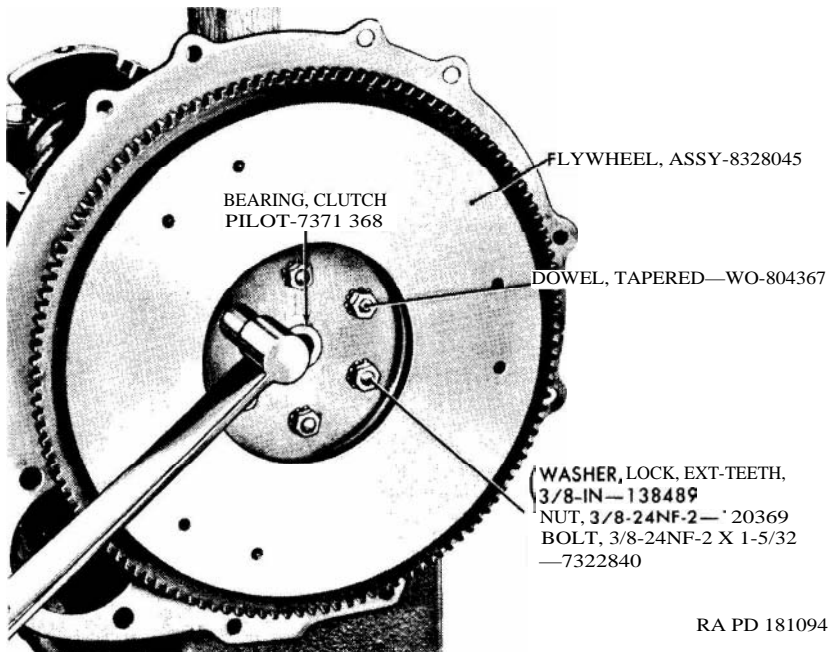

Figure 83. Installing flywheel assembly.

b. Thoroughly lubricate the piston rings with engine oil and compress the piston rings with a ring compressing tool.

c. Turn the crankshaft so that the crankpin of the piston about to be installed is at bottom center. Matching the piston and connecting rod to the cylinder bore to which it was fitted (par. 60b (5)), start the piston *into* the top of the cylinder block (*fig. 84*) so that the narrow side of the connecting rod offset is adjacent to the nearest main bearing (*fig. 46*). When correctly positioned, the side of the

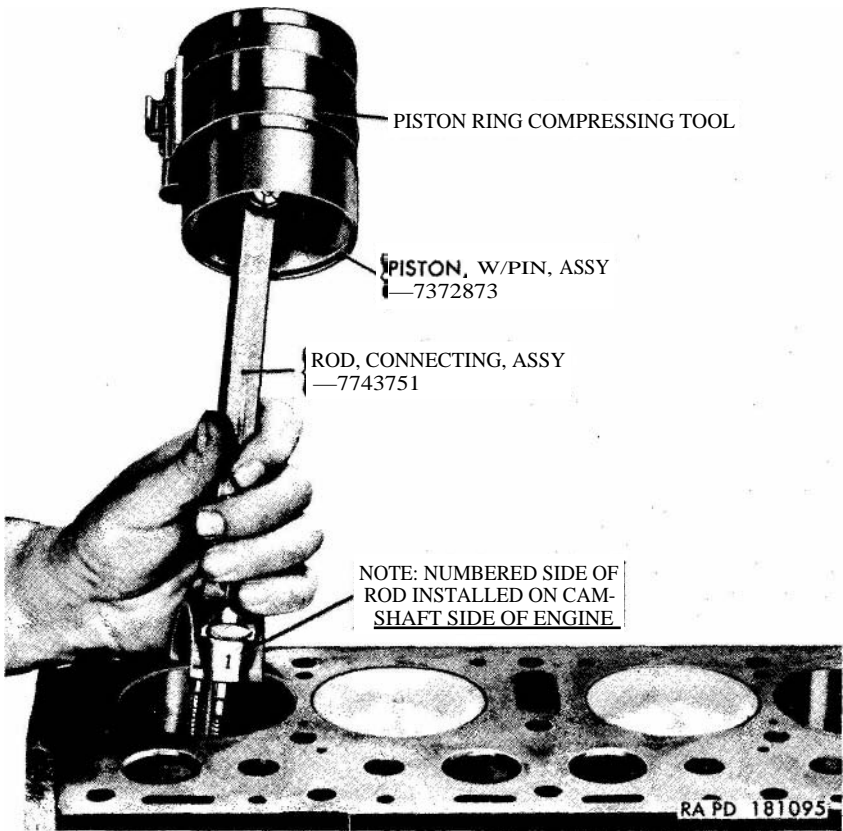

Figure 84. Installing pistons and connecting rods.

connecting rod stamped with the cylinder identifying number is on the camshaft side of the engine (*fig. 84*). Use the handle end of a hammer to tap the piston through the ring compressing tool and down two or three inches into the cylinder.

d. Reach up from the bottom of the cylinder block and pull the end of the connecting rod down over the crankshaft journal. Install the cap and half bearing on the rod half of the rod and the bearing, numbered side of cap to numbered side of rod, and secure in place with

the connecting rod bolts and nuts (fig. 18) tightened to 50 to 55 pound-feet of torque.

Note. Do not install the $\frac{3}{8}$ -24NF jam nuts at this time.

e. Check the connecting rod bearing for clearance following instructions given in paragraph 97a for checking main bearing clearance, except that the shim used should be 0.001-inch thick instead of 0.002-inch thick (repair and rebuild standards (par. 143c)).

f. Repeat operations *a* through *e* above on each of the other three assemblies.

g. Upon completion of the bearing sizing operation, installation, and torquing of the retaining nuts, install new $\frac{3}{8}$ -24NF jam nuts, with outer raised edges out, finger tight. Use a wrench to turn the jam nuts an additional one-quarter turn to lock them in position.

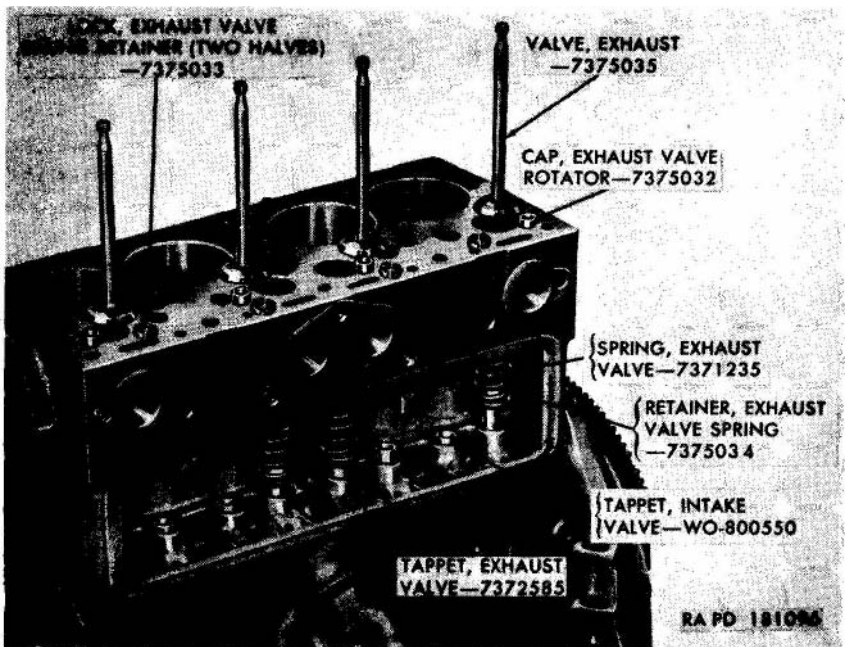

Figure 85. Installing exhaust valves and related parts.

105. Install Exhaust Valves and Related Parts

(fig. 85)

a. Take particular care to keep each exhaust valve and its related parts separate from the other exhaust valves and valve parts (par. 87c(2) (b)5). Install one exhaust valve spring and exhaust valve spring retainer on each exhaust valve tappet making sure the end of the spring with the closely spaced coils is on top, and properly seated in the cylinder block. (Figure 40 shows the difference between

the two ends of the intake valve springs and in this respect the exhaust valve springs are similar.)

Note. Exhaust and intake valve springs look alike but are different. They must not be interchanged.

Insert an exhaust valve into each of the exhaust valve guides.

b. Turning the crankshaft as necessary to bring each exhaust valve tappet to its lowest position and, using a valve lifter, raise the valve spring and valve spring retainer and install the exhaust valve retainer lock (two halves) **and the** rotator cap on each of the exhaust valves.

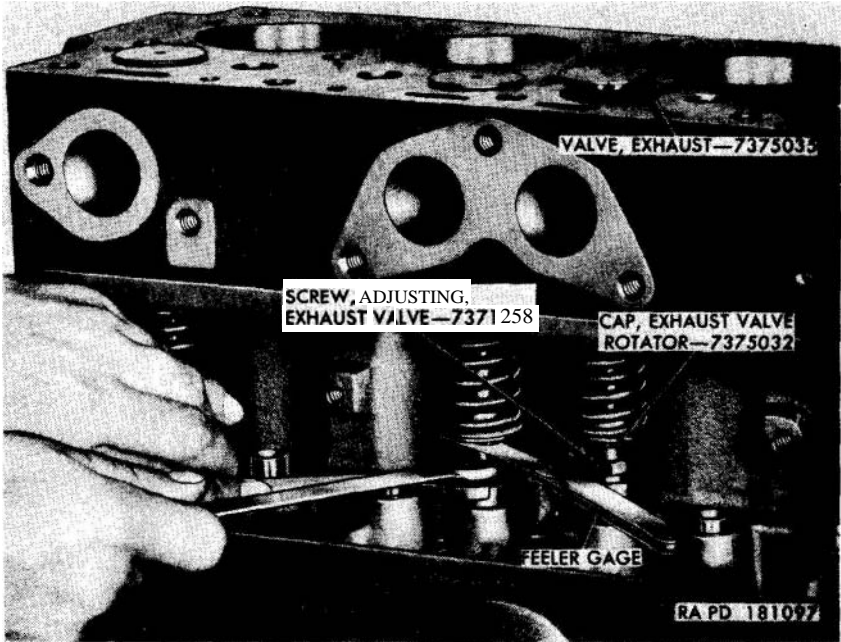

Figure 86. Adjusting exhaust valves.

106. Adjust Exhaust Valve

(fig. 86)

a. Turn the crankshaft as necessary to bring the exhaust valves to the closed position (valve head against the valve seat in the cylinder block).

b. Turn the exhaust valve adjusting screws in or out of the exhaust valve tappets as necessary to obtain a clearance of 0.016- to 0.017-inch between the end of the adjusting screw and the bottom of the exhaust valve rotator cap (repair and rebuild standards (par. 150a)).

107. Adjust Crankshaft End Play

a. Temporarily install the crankshaft drive gear spacer (AB, fig. 9) (cupped side against the gear), the crankshaft oil slinger (AC, fig. 9),

the fan and generator drive pulley (A, fig. 9), and the $1\frac{1}{16}$ -inch nut (B, fig. 9) on the front end of the crankshaft. Do not install the fan and generator drive pulley woodruff key (AF, fig. 9). Tighten the $1\frac{1}{6}$ -inch nut. Insert a screwdriver or other suitable pry-bar between the center main bearing support and the crankshaft number two counterweight (fig. 87) and pry the crankshaft forward. Insert a feeler gage between the crankshaft thrust washer and the flanged edge of the front main bearing and measure the crankshaft end play. This clearance must be between 0.004- and 0.006-inch (repair and rebuild standards (par. 143a.)).

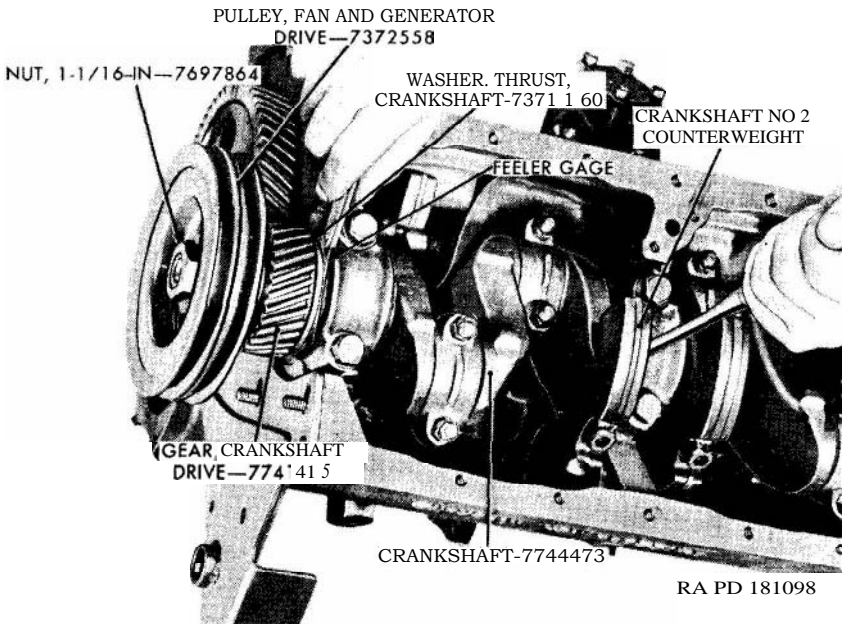

Figure 87. Gaging crankshaft end play.

b. If the clearance is less than 0.004-inch, carefully gage the actual amount of clearance. Remove the $1\frac{1}{16}$ -inch nut, the fan and generator drive pulley, the crankshaft oil slinger, and the crankshaft drive gear spacer. Use puller 41-P-2956-4 (fig. 19) to pull the crankshaft drive gear forward on the shaft about one inch. Reach into the space between the crankshaft thrust washer (fig. 88) and crankshaft front bearing with a pair of thin-nose pliers and grasp one of the crankshaft end play adjusting shims. Jerk the shim to tear it and release it from the crankshaft. If the removal of additional shims is necessary, they may be removed in the same manner.

(Total shim thickness to be removed is determined by subtracting the actual clearance from the desired clearance of from 0.004 to 0.006-inch).

c. If the above operations were carefully performed, no rechecking is necessary. However, if there is any doubt as to the accuracy of the adjustment, recheck as instructed above. Remove the 11/16-inch nut and the fan and generator drive pulley when the crankshaft end play has been properly adjusted.

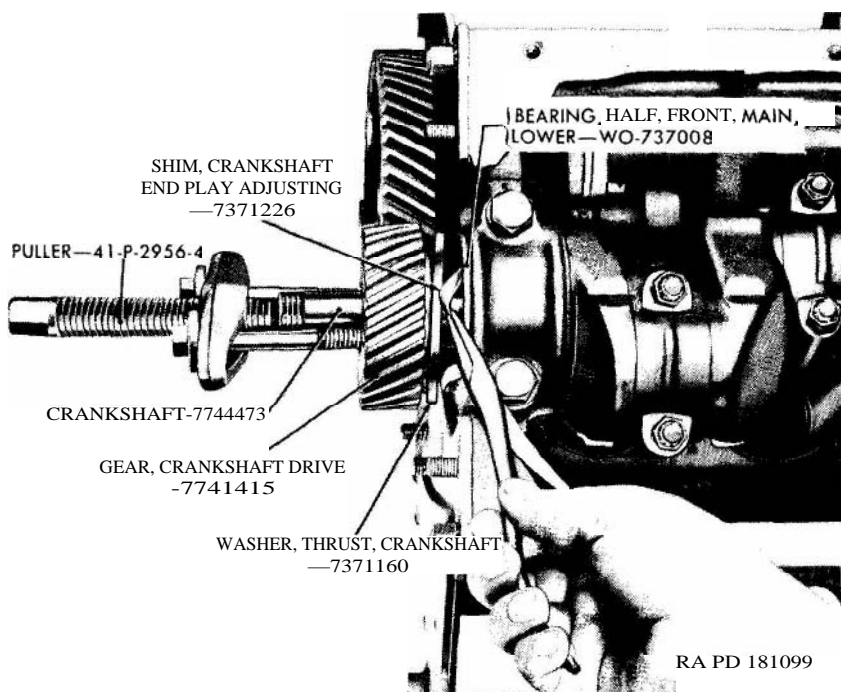

Figure 88. Removing crankshaft end play adjusting shim.

108. Install Timing Gear Cover

a. Install the $\frac{3}{16}$ x $\frac{3}{4}$ fan and generator drive pulley Woodruff key (AG, fig. 9) in the key slot on the front end of the crankshaft.

b. Coat both sides of the timing gear cover gasket (AM, fig. 70) with liquid type gasket cement and install the cover and the gasket on the front end of the engine. Secure the cover in place with three $\frac{3}{8}$ -24NF-3 x $\frac{3}{4}$ bolts (fig. 89) and one $\frac{3}{8}$ -24NF-3 x 1 bolt. Use eight $\frac{3}{8}$ -24NF-3 lock washer nuts, four of which are used on the previously installed studs.

Note. Do not tighten the nuts until the fan and generator drive pulley has been installed (par. 109).

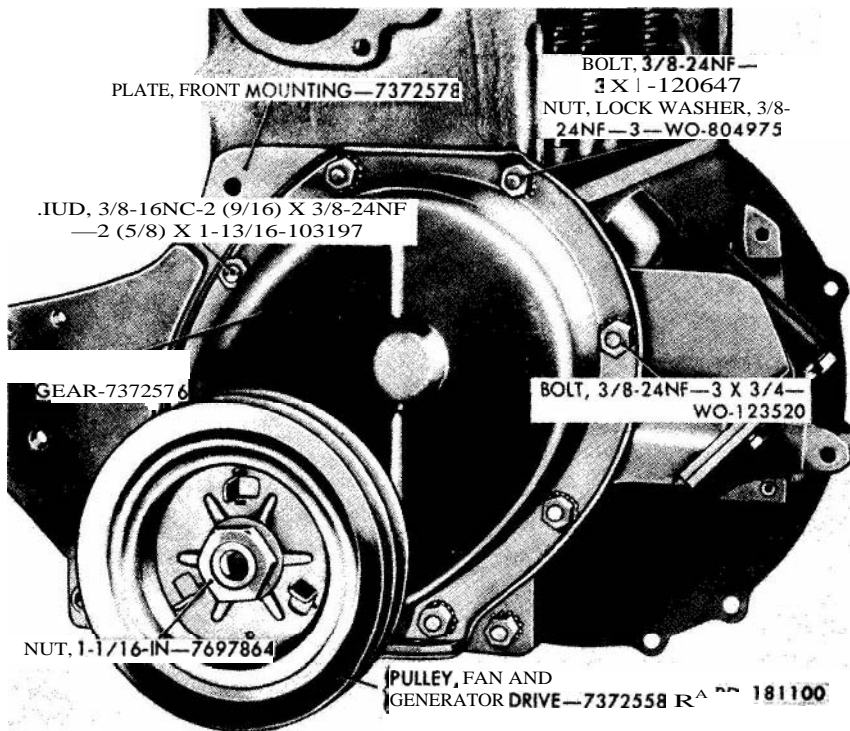

Figure 89. Timing gear cover, and fan and generator drive pulley.

109. Install Fan and Generator Drive Pulley

- a. Align the keyway in the fan and generator drive pulley with the Woodruff key installed in the crankshaft. Drive the fan and generator drive pulley onto the crankshaft and secure it in place with the $\frac{1}{6}$ -inch nut. Insert a block of wood between one of the counterweights on the crankshaft and the side of the cylinder block to prevent the crankshaft from turning when tightening the nut.
- b. Tighten the eight timing gear cover nuts.

110. Install Oil Strainer Assembly and Oil Pan

- a. Install the two dowel bolts one on either side of the engine (figs. 21 and 22), to serve as locating dowels for the engine rear mounting plate.

Note. If the engine is installed in a repair stand, it will be impossible to install the right hand bolt. In this event, insert a $\frac{1}{2}$ x 1 bolt into the hole from the opposite side of the mounting plate. Nuts and washers need not be installed.

- b. Install two $\frac{5}{16}$ -18NC-3 x $\frac{3}{4}$ cap screws (fig. 90) and two copper gaskets to attach the rear mounting plate support to the underside of the cylinder block. Tighten the screws to 12-17 pound-feet torque.

c. Tighten the $\frac{1}{4}$ -20NC-2 x $\frac{1}{2}$ socket-head cap screws (fig. 90) attaching the rear mounting plate support to the rear mounting plate.

d. Coat both sides of the oil strainer support gasket (fig. 18) with plastic type gasket cement and install the gasket and the oil strainer assembly in position on the underside of the cylinder block. Use two $\frac{5}{16}$ -18NC-2 x $\frac{3}{8}$ lock washer cap screws to secure the oil strainer in place.

e. Coat both sides of the oil pan gasket (fig. 91) with liquid type gasket cement. Loosely attach the oil pan and gasket to the bottom of the cylinder block with fourteen $\frac{5}{16}$ -18NC-2 x $\frac{3}{8}$ lock washer cap screws installed in the side and rear mounting holes. Do not install cap screws in the front six holes.

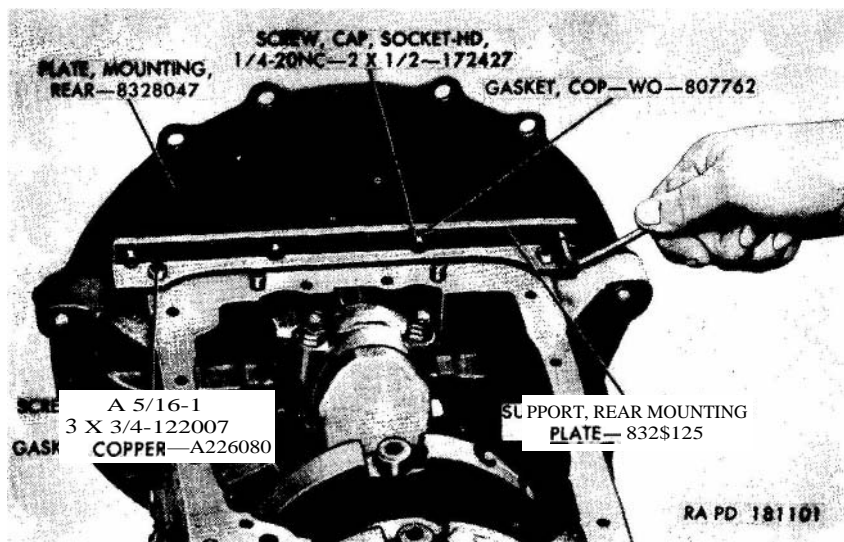

Figure 90. Tightening rear mounting plate support cap screws.

f. Center a fan and generator drive pulley shield spacer gasket (fig. 17) and a pulley shield spacer over each of the oil pan front mounting holes. Install the fan and generator drive pulley shield (fig. 91) on top of the spacers with the squared side of the shield on the oil pump side of the engine. Secure the shield in place with six $\frac{5}{16}$ -18NC-2 x $1\frac{1}{8}$ lock washer cap screws. Tighten the pulley shield cap screws and the oil pan cap screws to 12--17 pound feet torque.

111. Install Water Pump Assembly

Coat both sides of the water pump to cylinder block gasket (fig. 92) with plastic type gasket cement. Install the water pump and gasket on the front end of the engine using one $\frac{3}{16}$ -18NC-2 x $2\frac{1}{2}$

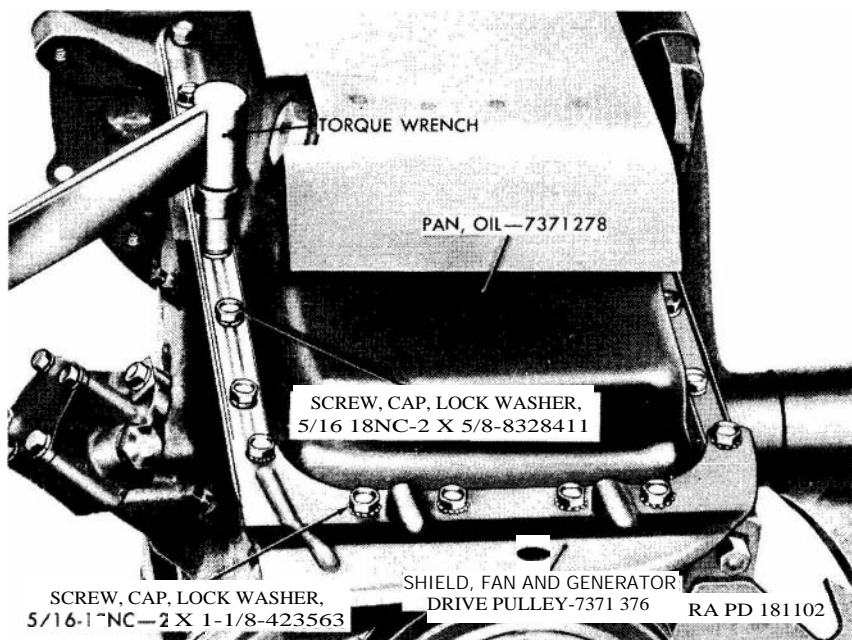

Figure 91. Installing oil pan and fan and generator drive pulley shield

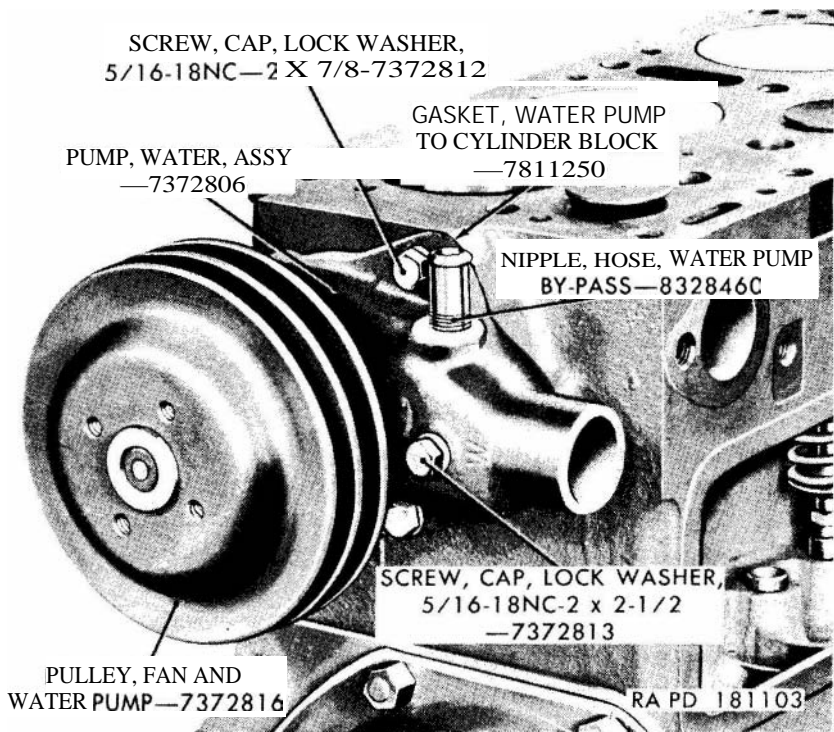

Figure 92. Water pump assembly.

lock washer cap screw and three $\frac{3}{16}$ -18NC-2 x $\frac{7}{8}$ lock washer cap screws to secure the water pump in place. Tighten cap screws to 12-17 pound feet torque.

112. Install Cylinder Head

a. Center the cylinder head gasket on the top of the cylinder block. Set the cylinder head in place on the gasket and install the ten $\frac{7}{16}$ -14NC-2 x $4\frac{1}{4}$ cap screws and the ten plain washers in the locations shown in figure 15.

b. Using the same size cap screws, but no washers, install the upper bellcrank accelerator bracket (fig. 93) and the oil filter mounting bracket, installing cap screw in the front mounting hole only of the oil filter bracket.

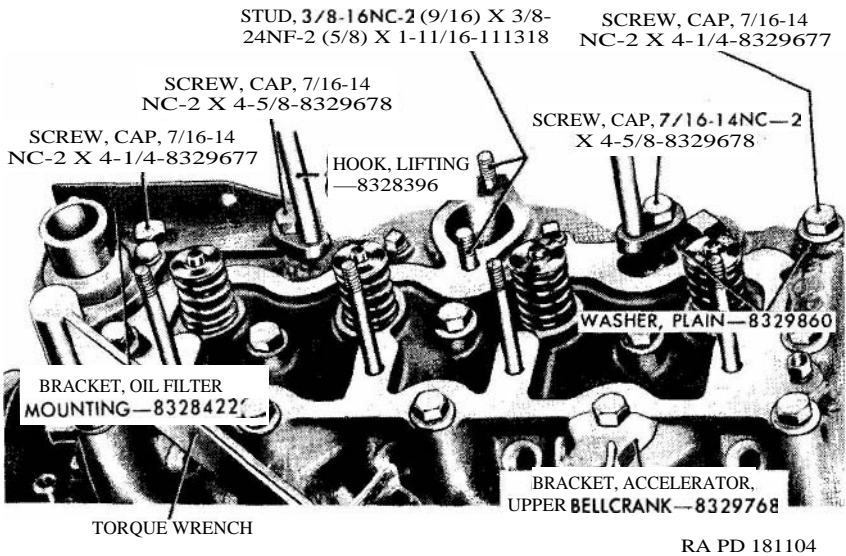

RA PD 181104

Figure 93. Metalling cylinder head.

c. Center a plain washer (fig. 93) on the cylinder head mounting hole, just to the rear of the carburetor mounting flange, and set the mounting feet of the engine lifting hook on the washer and on the rear end of the oil filter mounting bracket. Secure the hook in place using two $\frac{7}{16}$ -14NC-2 x $4\frac{5}{8}$ cap screws.

d. Install the $\frac{7}{16}$ -14NC-2 x $1\frac{11}{16}$ cap screw (fig. 15) in the cylinder head mounting hole at the bottom of the carburetor inlet opening.

e. Tighten all cap screws to 60 to 65 pound-feet torque in the sequence shown in figure 94.

f. Install the two $\frac{3}{8}$ -16NC-2 ($\frac{9}{16}$) x $\frac{3}{8}$ -24NF-2 ($\frac{5}{8}$) x $1\frac{1}{6}$ studs (fig. 93) in the tapped openings on either side of the carburetor mounting boss.

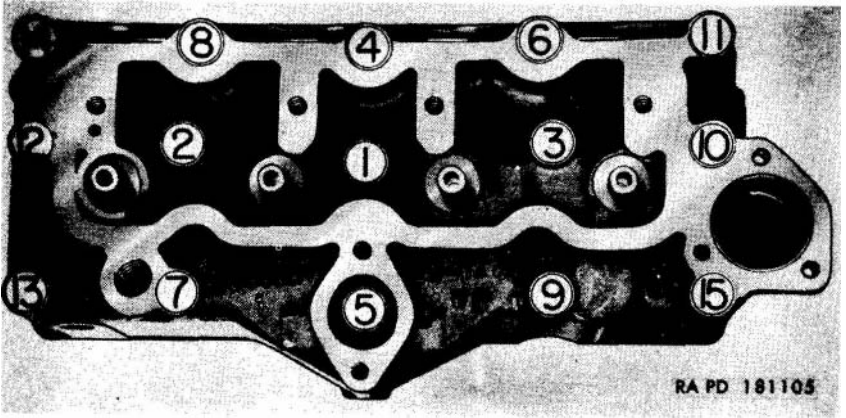

Figure 94. Cylinder head cap screw tightening sequence.

113. Install Rocker Arms and Related Parts

a. Lower the intake valve push rods, ball end first, through the cylinder head and cylinder block, seating the ball ends of the rods into the cupped ends of the intake valve tappets.

b. Install the rocker arms and shaft assembly on the four rocker arm shaft bracket studs (fig. 14). Remove the two temporarily installed rocker cover studs (par. 58e). Using one $\frac{5}{16}$ -inch internal teeth lock washer (fig. 95) between each stud and rocker arm shaft bracket, install the studs so that the short threaded ends enter the tapped holes in the brackets. Install four $\frac{3}{8}$ -24NC-2 lock nuts on the rocker arm shaft bracket studs. Tighten the nuts to 30 to 36 pound-feet torque.

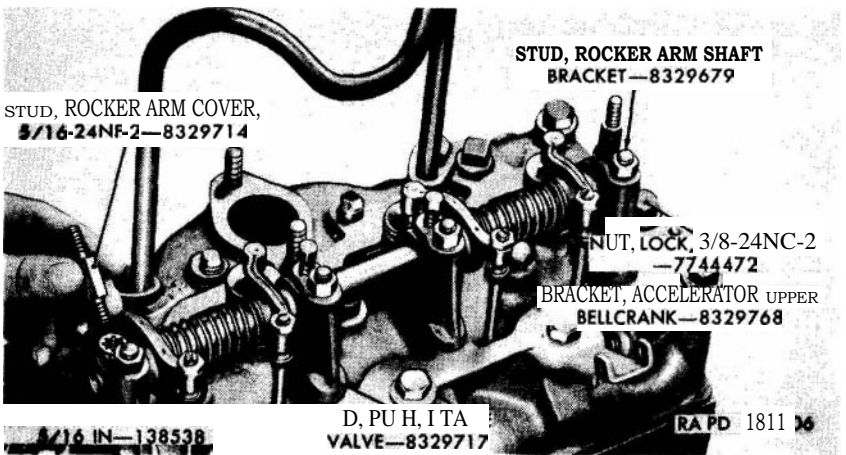

Figure 95. Installing rocker arm cover studs.

114. Adjust Intake Valves

a. Turning the crankshaft as necessary to bring each intake valve in turn to the fully closed position, adjust the rocker arm to intake valve clearance to 0.018- to 0.020-inch (repair and rebuild standards (par. 149a)).

b. Adjust the clearance by loosening the intake valve adjusting screw lock nut (*fig. 96*) and turning the adjusting screw in or out to close or open the gap between the end of the intake valve and the rocker arm. Turn the screw clockwise to close the gap and counter-clockwise to open the gap. When the gap is adjusted so that a 0.018-

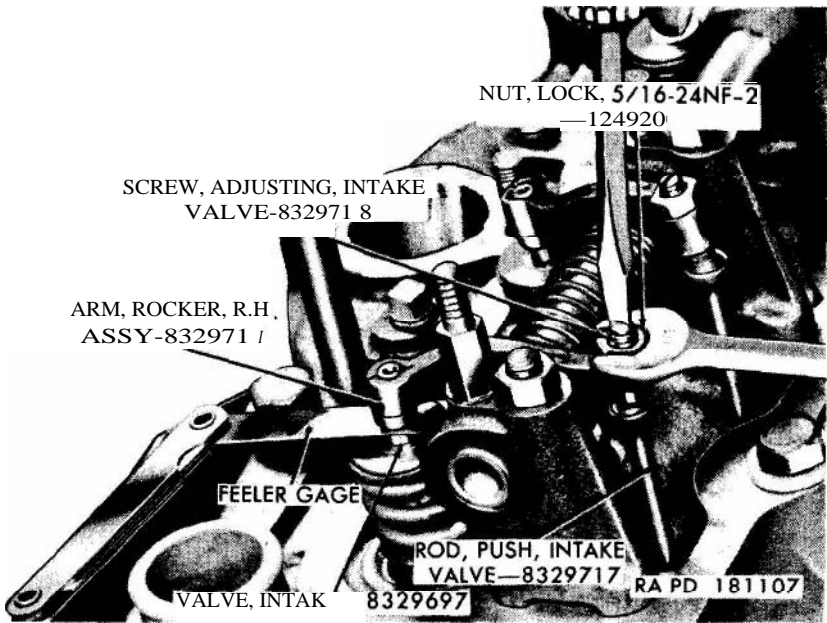

Figure 96. Adjusting intake valve clearance.

inch feeler gage can be inserted with only a light feeling of resistance, hold the adjusting screw in that position and tighten the lock nut. Check the gap after locking the screw to make sure that the gap is unchanged.

115. Install Oil Lines and Water Pump Bypass Tube

(*fig. 97*)

a. Install the crankcase to cylinder head oil line $\frac{3}{16}$ -inch clip (Y) on the rear end of the engine. Use a 14-20NC-2 x $\frac{1}{2}$ lockwasher cap screw (L) to attach the clip to the engine.

b. Install the crankcase to cylinder head oil line 90° elbow (P) in the cylinder block. Install the crankcase to cylinder head oil line (K)

connecting it to the $\frac{3}{16}$ -inch connector (H) in the cylinder head and to the 90° elbow (P) in the cylinder block. Snap the line into the line $\frac{3}{16}$ -inch clip (Y).

c. Install the 90° elbow (N) in the cylinder block and connect the sending unit oil line (M) to the elbow.

d. Install the 90° elbow (GG) in the cylinder block and connect the non-swiveled end of the oil filter inlet flexible line (A) to the elbow. Install one of the $\frac{3}{16}$ -inch clips (C) on the flexible line and under the head of the timing gear cover bolt as shown in figure 97 and the second clip (C) under the head of the water pump upper attaching cap screw.

e. Install the water pump bypass tube (F) on the nipples installed in the cylinder head and the water pump, and secure in place with $\frac{15}{16}$ -inch hose clamps (E).

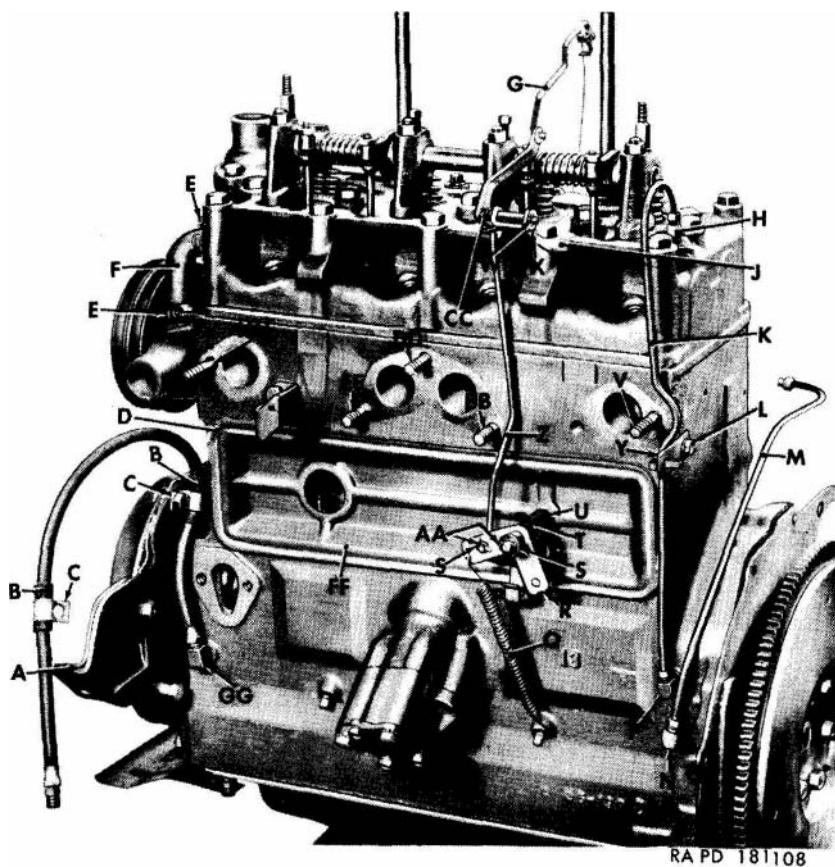

Figure 97. Left side view of engine partially assembled.

116. Install Exhaust Valve Spring Compartment Cover

(fig. 97)

Coat both sides of the exhaust valve spring compartment cover gasket (D) with plastic type gasket cement and install the exhaust valve spring compartment cover (FF) and the gasket. Install the exhaust valve spring compartment cover special stud (T) using a stud gasket (U) between the shoulder on the stud and the cover.

117. Install Throttle Linkage

(fig. 97)

a. Slide the accelerator lower bellcrank (R) onto the exhaust valve spring compartment cover special stud (T) so the projecting hub of the bellcrank faces out. Install an $1\frac{1}{32}$ ID, $1\frac{1}{16}$ OD plain washer (AA) and a $\frac{1}{16} \times \frac{1}{2}$ cotter pin (S) on the end of the stud to secure the bellcrank in place.

b. Slide the accelerator bellcrank spring (CC) onto the shaft of the accelerator upper bellcrank (JJ) and insert the shaft into the accelerator upper bellcrank bracket (J) attached to the cylinder head. Install an $1\frac{1}{2}$ ID, $1\frac{1}{16}$ OD plain washer (X) and a $\frac{1}{16} \times \frac{1}{2}$

A—Line, flexible, oil filter inlet, assy-8328409	T—Stud, special, exhaust valve spring compartment cover—WO-806348
B—Loom, split, $\frac{3}{16} \times 1$ —WO-A17445	U—Gasket, exhaust valve spring compartment cover stud—WO-51875
C—Clip, $\frac{9}{16}$ -inch—107839	V—Stud, $\% - 16 \times 1\frac{1}{2}$ —WO-300143
D—Gasket, exhaust valve spring compartment cover—WO-630305	W—Pin, cotter, $\frac{1}{16} \times 1/2$ -112726
E—Clamp, hose, $\frac{3}{16}$ -inch (water pump bypass)-502913	X—Washer, plain, $1\frac{1}{32}$ $1\frac{1}{16}$ OD—120893
F—Tube, water pump bypass, assy-7372962	Y—Clip, $\frac{1}{16}$ -inch—WO-645539
G—Rod, throttle-8329763	Z—Rod, accelerator bellcrank link-8329765
H—Connector, $\frac{3}{16}$ -inch—137404	AA—Washer, plain, $1\frac{1}{32}$ ID, $1\frac{1}{16}$ OD-120393
J—Bracket, accelerator upper bellcrank-8329768	BB—Stud, $\frac{3}{8}$ -16NC-2 ($\frac{1}{16}$) \times $\frac{3}{8}$ -24NF-2 ($\frac{3}{8}$) \times $2\frac{1}{8}$ —WO-A564
K—Line, oil, crankcase to cylinder head, assy-8328408	CC—Spring, accelerator bellcrank-8329770
L—Screw, cap, lockwasher, $\frac{1}{4}$ -20NC-2 \times $1/2$ —WO-800226	DD—Stud, $\frac{3}{8}$ -16NS ($1\frac{1}{2}$) \times $\frac{3}{8}$ -24NF ($\frac{3}{8}$) \times $1\frac{3}{4}$ —WO-800800
M—Line, oil, sending unit, assy-8328407	EE—Stud, $\% - 16NC-2$ ($\frac{3}{16}$) \times $\frac{3}{8}$ -24NF-2 ($\%$) \times $2\frac{1}{8}$ —WO-A564
N—Elbow, 90 deg-137421	FF—Cover, exhaust valve spring compartment—WO-807707
P—Elbow, 90 deg-137420	GG—Elbow, 90 deg—444038
Q—Spring, return, accelerator pedal-8329764	HH—Stud, $\% - 16 \times 1\frac{1}{2}$ —WO-300143
R—Bellcrank, accelerator, lower-8329766	JJ—Bellcrank, accelerator, upper-WO-805478
S—Pin, cotter, $\frac{1}{16} \times 1/2$ -112726	

Figure 97.—Continued

cotter pin (W) on the end of the bellcrank shaft to secure the **bellcrank** in place.

c. Insert the two ends of the accelerator **bellcrank** link rod (Z) into the upper and lower **belleranks** and secure the rod in place with two $1\frac{1}{32}$ ID, $1\frac{1}{16}$ OD plain washers (AA) and two $\frac{1}{16} \times \frac{1}{2}$ cotter pins (S). Insert the end of the throttle rod (G) into the hole in the end of the extension arm of the upper **bellerank** and secure ill place with an $1\frac{1}{32}$ ID, $1\frac{1}{16}$ OD plain washer (X) and a $\frac{1}{16} \times \frac{1}{2}$ cotter pin (W).

d. Install the accelerator pedal return spring (Q) hooking one end of the spring into the hole in the head of the $\frac{1}{8}$ -inch pipe plug located in the lower part of the cylinder block, and the opposite end into the hole in the lower bellcrank.

118. Install Exhaust Manifold Studs

(fig. 97)

a. Coat the threads of all exhaust manifold studs with plastic type gasket cement. Install one $\frac{3}{8}$ -16 x $1\frac{1}{2}$ exhaust manifold stud (V and HH) in each of the end manifold mounting holes, one $\frac{3}{8}$ -16NS ($\frac{1}{2}$ x $\%$ -24NF ($\frac{7}{8}$) x 1% stud (DD) in the center manifold mounting hole, and one $\%$ -16NC-2 ($\frac{9}{16}$) x $\%$ -24NF-2 ($\%$) x $2\frac{1}{8}$ stud (EE and BB) in the mounting holes on either side of the center exhaust ports.

b. Install the dual control support (J, fig. 99) on the left side of the engine using a $\frac{3}{8}$ -16NC-2 x $\frac{5}{8}$ lockwasher cap screw (K, fig. 99) to secure the support in place.

PUMP, FUEL, ASSY—WO—805727

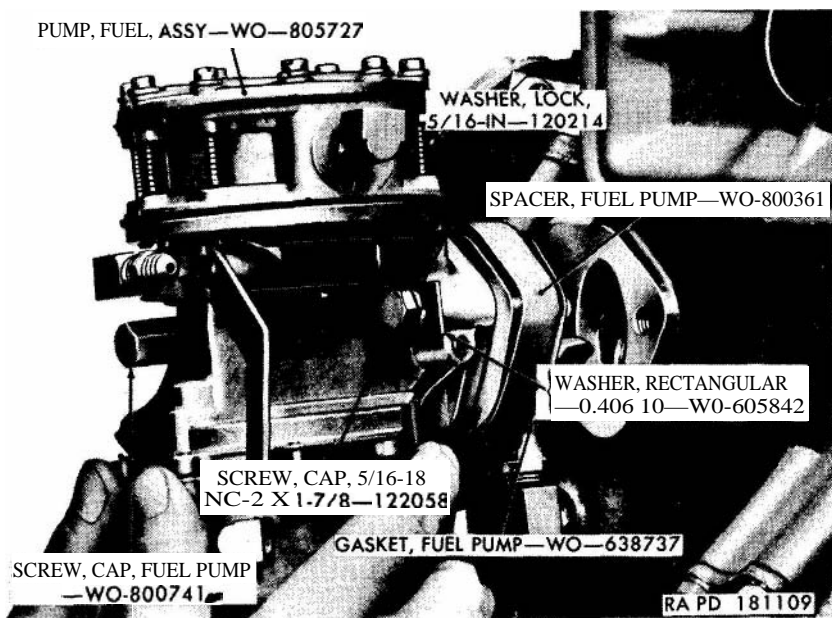

Figure 98. Installing fuel pump assembly.

119. Install Fuel Pump Assembly

a. Before installing the fuel pump, turn the camshaft (by turning the crankshaft) to bring the low side of the fuel pump actuating cam directly opposite the fuel pump mounting hole.

b. Coat both sides of the two fuel pump gaskets (fig. 98) with plastic type gasket cement. Assemble a $\frac{1}{16}$ -inch lockwasher and the 0.406 ID rectangular washer onto the $\frac{5}{16}$ -18NC-2 x 1 $\frac{7}{8}$ s cap screw. Assemble identical parts on the fuel pump cap screw and coat the threads of the cap screws with plastic type gasket cement. Insert the cap screws through the bolting flange of the pump as shown in figure 98. Assemble a fuel pump gasket, the fuel pump spacer and the second fuel pump gasket onto the cap screws as shown in figure 98, and install the fuel pump on the engine.

120. Install Lower Crankcase Vent Control Valve and Related Parts

Coat both sides of the crankcase vent body gasket (U) with plastic type gasket cement. Secure the gasket and the lower crankcase vent control valve (G) and its related parts (fig. 115) to the engine using the crankcase vent body cap screw (W) and a copper gasket (V) to secure the crankcase vent body (L) to the exhaust valve spring compartment cover and to the cylinder block.

121. Install Fuel and Vent Lines

(fig. 99)

a. Connect the fuel pump inlet flexible line (D) and the fuel pump to carburetor line (E) to the fuel pump (X).

b. Install the ball check connector (C) in the elbow installed in the center section of the fuel pump. Connect the pressure line (B) to the ball check connector. Install the $\frac{7}{16}$ x 1 split loom (P) over the pressure line and insert the line behind the clip welded to the exhaust valve spring compartment cover.

c. Connect the crankcase vent line (F, fig. 105 and CC, fig. 4) to the $\frac{1}{8}$ -inch tee, in the intake manifold securing the line in place, by installing the $\frac{5}{16}$ -inch crankcase vent line clip (DD, fig. 4) under the head of the bottom water pump attaching cap screw. Snap the 0.031 OD double clips (J, fig. 105) over the crankcase vent line and the fuel pump to carburetor lines at the approximate locations shown in figure 105.

d. Connect the vent line (metering valve to vacuum pump) (F) to the tee on the end of the crankcase vent metering valve (H) and to the elbow in the lower section of the fuel pump assembly (X).

e. Install the $\frac{3}{16}$ -inch special connector (R) in the side opening of the $\frac{1}{4}$ -inch inverted flared tube tee (S) and attach the distributor vent line (Q), windshield wiper line (T), and the vent line (A) to the

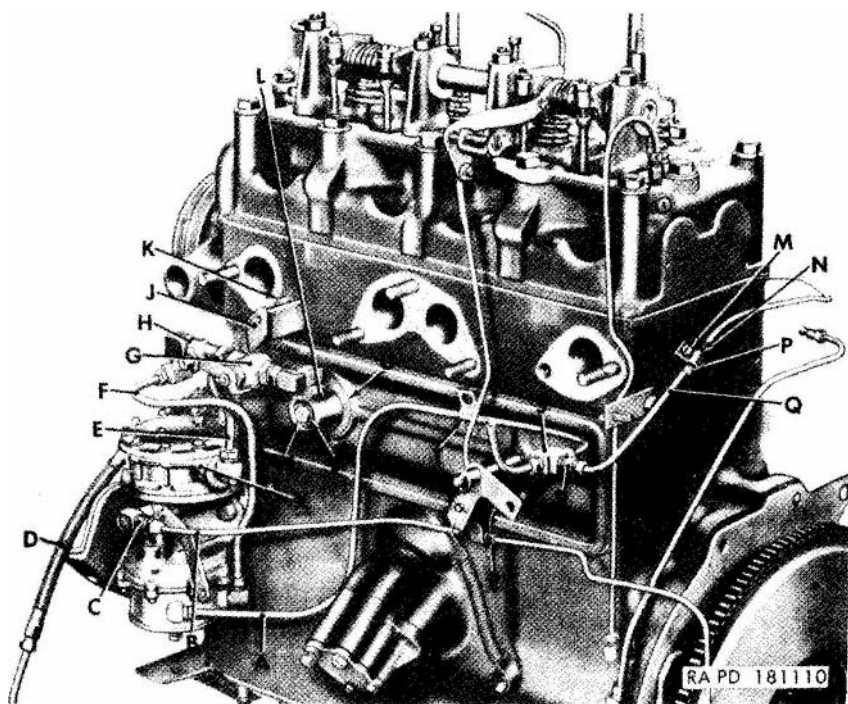

- | | |
|---|--|
| A—Line, vent | M—Screw, cap, lock washer— $\frac{1}{4}$ -20NC-2 x WO-800226 |
| B—Line, pressure—WO-807700 | N—Clip, $\frac{3}{16}$ -inch—120522 |
| C—Connector, ball check-7375063 | P—Loom, split, $\frac{3}{16}$ x 1—WO-A17445 |
| D—Line, flexible, fuel pump inlet—WO-806172 | Q—Line, vent distributor to windshield wiper tee—WO-806420 |
| E—Line, fuel pump to carburetor—8329639 | R—Connector, special, $\frac{3}{16}$ -inch—WO-802665 |
| F—Line, vent metering valve to vacuum pump | S—Tee, $\frac{1}{4}$ -inch, inv flared tube-178910 |
| G—Valve, vent control, lower crankcase-7410836 | T—Line, tee to windshield wiper—8329998 |
| H—Valve, metering, vent, crankcase-5336400 | U—Gasket, crankcase vent body—WO-630299 |
| J—Support, dual control—WO-806449 | V—Gasket, cop—WO-51875 |
| K—Screw, cap, lock washer, $\frac{3}{8}$ -16NC-2 x $\frac{5}{8}$ —7348875 | W—Screw, cap, crankcase vent body—WO-645093 |
| L—Body, vent, crankcase-7371286 | X—Pump, fuel, assy—WO-805727 |

Figure 99, Installation details of lines and fittings, left side of engine.

tee (S). Connect the opposite end of the vent line (A) to the elbow in the lower section of the fuel pump. Install the $\frac{3}{16}$ x 1 split loom (P) and the $\frac{3}{16}$ -inch clip (N) on the distributor to windshield wiper tee vent line (Q) and attach the clip loosely to the rear of the cylinder block with a $\frac{1}{4}$ -20NC-2 x $\frac{1}{2}$ lock washer cap screw (M).

122. Install Exhaust Manifold

Install the exhaust manifold gaskets (fig. 100) and the exhaust manifold over the studs. Install a $\frac{1}{2}$ ID, $\frac{13}{16}$ OD, plain washer on the center stud only. Lift the vent line (A, fig. 99) slightly and slide

the $\frac{5}{16}$ -inch line clip (*fig. 100*) onto the vent line and over the bottom exhaust manifold stud. Install the five $\frac{3}{8}$ -24NF-3 self-locking nuts on the manifold studs and tighten to 29-35 pound-feet torque. Tighten the cap screw (M, *fig. 99*) securing the distributor to windshield wiper tee vent line (Q, *fig. 99*) to the rear of the engine.

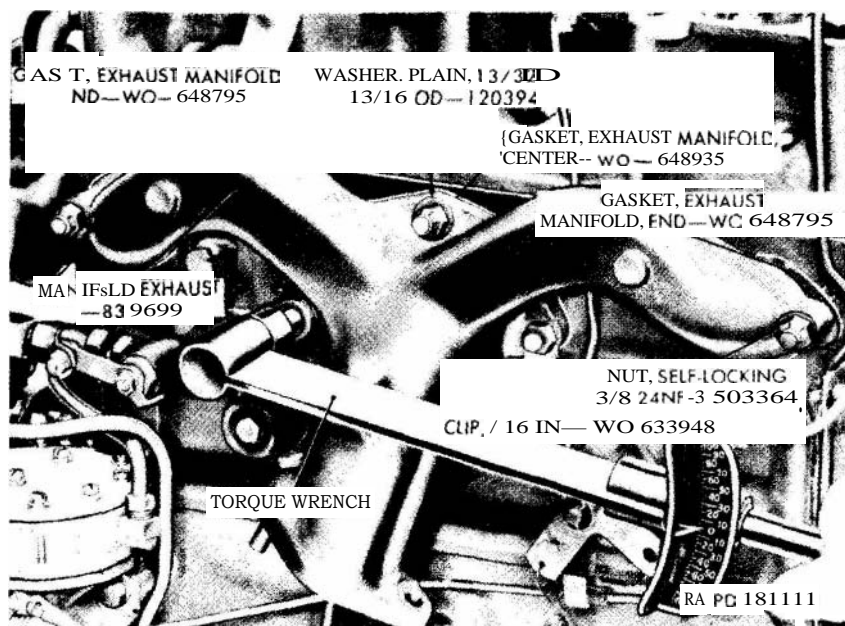

Figure 100. Tightening exhaust manifold stud nuts.

123. Install Clutch

a. Obtain an input shaft from a scrapped transmission and cut off the integral gear from the end of the shaft. Using the shaft as an improvised *clutch* alining tool (*fig. 101*), position the driven disk with/facings and hub assembly against the engine flywheel with the hub extension of the disk facing away from the flywheel.

b. Install the pressure plate with/cover assembly (*fig. 102*) and secure it in place with six $\frac{5}{16}$ -inch lock washers and $\frac{5}{16}$ -18NC-2 x $\frac{1}{16}$ cap screws. Hold the improvised clutch alining tool firmly in place while tightening the pressure plate cap screws. To avoid distorting the plate, tighten the screws a little at a time and evenly around the circle.

c. Check the setting of the pressure plate release levers. The outer edge of the levers should be exactly $\frac{27}{32}$ inch from the web of the pressure plate directly behind the levers. This distance may be measured with a rule; however, the improvised clutch pressure plate release lever checking gage (*figs. 8 and 103*) will facilitate the checking and adjusting of the levers as follows :

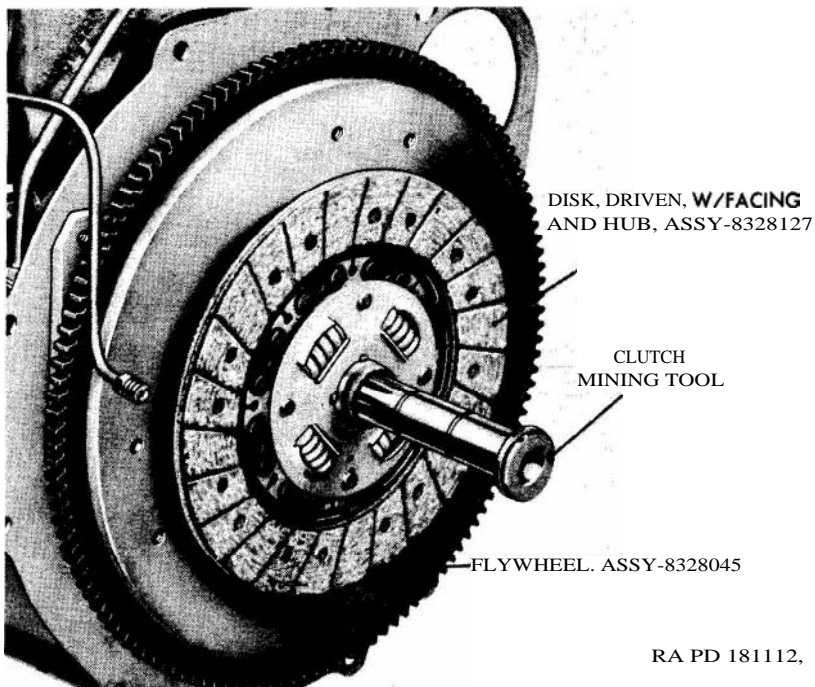

Figure 101. Installing clutch driven disk w/facings and hub assembly.

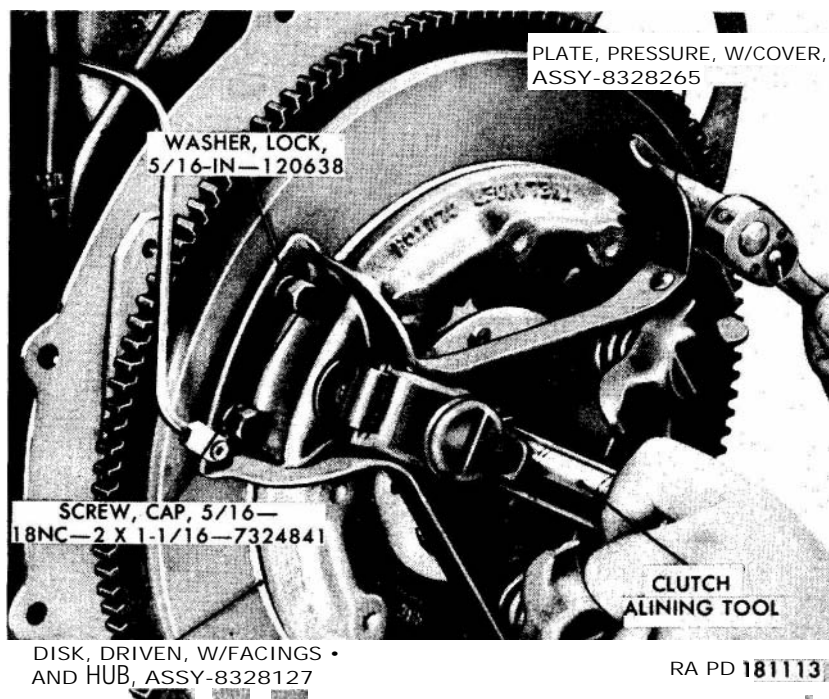

Figure 102. Installing clutch pressure plate w/cover assembly.

- (1) When the gage is held in the position shown in figure 103, a correct setting is indicated when the end of the gage is against the web of the pressure plate and the outer edge of the release lever is just touching the front edge of the cutout section of the tool.
- (2) Check each of the three levers individually and make sure that all of the levers are within $27/32$ -inch, plus or minus 0.005-inch.

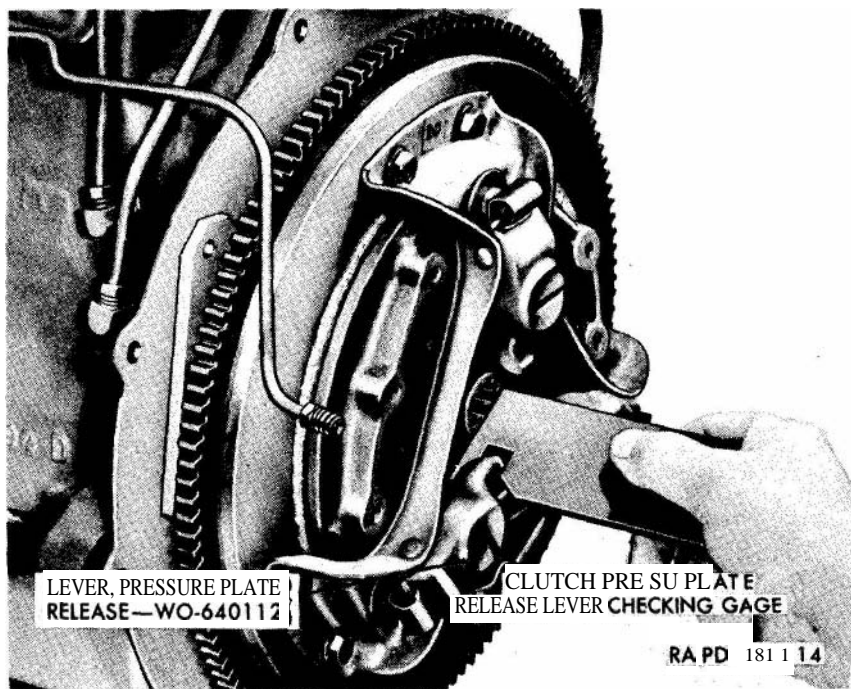

Figure 103. Checking clearance of release lever.

- (3) If necessary to adjust the levers, remove the pressure plate release lever clip (fig. 104) and loosen the adjusting cap screw lock nut. Turn the adjusting screw in or out as necessary to bring the end of the pressure plate release lever within the specified clearance. Replace the release lever clips upon completion of the adjusting operation.

124. Install Accessory Assemblies

(fig. 105)

a. If the engine assembly operation was begun with the cylinder block mounted in an engine overhaul stand, the engine must be removed from the stand at this point and placed upright on a suitable bench or stand.

b. Insert the two dowel bolts (figs. 21 and 22) through the clutch housing mounting boss at the rear of the engine and through the holes in the engine rear mounting plate.

Note. These bolts and bolt holes are machined to close tolerance. They provide the means whereby the clutch housing, to which the transmission is attached, is brought into correct alignment with the rear face of the engine. If difficulty is encountered in installing the dowel bolts, loosen the two cap screws which secure the engine rear mounting support plate to the underside of the engine (fig. 90). This will allow the rear mounting plate to move slightly and permit the dowel bolts to be installed. Tighten the rear mounting plate support attaching cap screws after the dowel bolts have been installed.

c. Install the six $\frac{3}{16}$ -24NF-3 x $\frac{7}{8}$ cap screws and $\frac{3}{16}$ -inch copper gaskets (M), three on each side of the engine, to secure the engine rear mounting plate in position.

d. Slide the oil filler pipe support bracket (H) over the oil filler pipe (E). Start the pipe into the oil filler pipe hole in the right side of the engine with the flattened section of the pipe facing out and parallel with the side of the engine. Place a block of wood, wider than the diameter of the pipe, over the top of the pipe and tap the pipe down into place. Insert the oil filler pipe bracket spacer (K) between the cylinder head and the oil filler pipe support bracket (H) and secure the bracket and spacer in place with a $\frac{3}{16}$ -18NC-2 x 1 $\frac{1}{4}$ lock washer cap screw (L).

e. Coat the threads of the water temperature sending unit (C) with

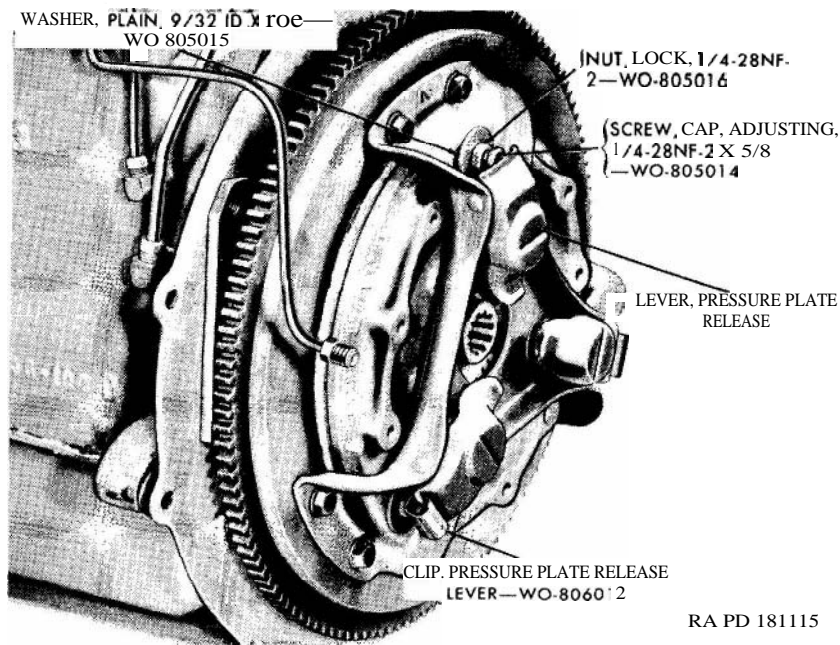
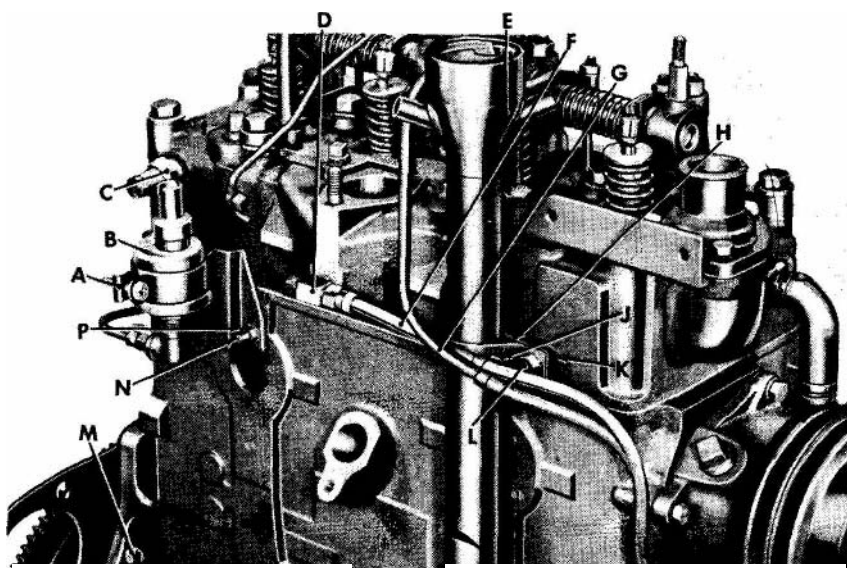

Figure 104. Location of clutch, pressure plate release lever adjusting screws.

A—SUPPORT, OIL PRESSURE SENDING UNIT-8329686
 8—UNIT, SENDING, OIL PRESSURE-7728856
 C—UNIT, SENDING, WATER TEMPERATURE-7389566

D—TEE, 1/8-IN—444132
 E—PIPE, OIL FILLER-8329683
 F—LINE, VENT, CRANKCASE-WO-806359
 G—LINE, FUEL PUMP TO CARBURETOR-WO-806065



H—BRACKET, SUPPORT, OIL FILLER
 PIPE—7368276
 J—CLIP, DOUBLE—WO-806096
 k—SPACER, OIL FILLER PIPE BRACKET
 —8329694
 L—SCREW, CAP, LOCK WASHER, 5/16-
 18NC-2 X 1-1/4-423564

M—SCREW, CAP, 5/16-24NF-3 X 7/8-
 120213—GASKET, COP, 5/16 IN—
 WO-805896
 N—STUD
 P—NUT, LOCK WASHER, 1/4-28NF-
 2—8329685

RA PD 181116

Figure 105. Installation details of lines and fittings—right side of engine.

plastic type gasket cement and install the unit in the tapped opening in the right side of the cylinder head.

f. Install the two oil pressure sending unit support studs (N) in the cylinder block. Install the support on the studs and secure in place with two $\frac{1}{4}$ -28NF-2 lock washer nuts (P). Install the oil pressure sending unit (B) in the support and connect the sending unit oil line (M, fig. 97) to the sending unit.

g. Install the oil filter assembly (TT, fig. 12) using two $\frac{3}{16}$ -24NF-2 x $\frac{3}{4}$ bolts and two $\frac{5}{16}$ -24NF-2 lock washer nuts to connect the filter to the filter support. Connect the oil filter inlet flexible line (A, fig. 97) to the inlet opening of oil filter. Connect the oil filter outlet flexible line (T, fig. 3) to the outlet connection of oil filter and to the connector welded to the timing gear cover.

Note. The above operations are for the Cuno filter. If the engine is equipped with the Fram military type filter there are four bolts holding the filter to the support.

h. Install the engine front mounting support cushions (H, fig. 70) one on each side of the engine front mounting plate, using $\frac{1}{2}$ -20NF-2B "Huglock" nuts (K, fig. 70) to secure the cushions in place.

i. Install the engine ground strap (C, fig. 12) on the front mounting plate. Use a $\frac{3}{8}$ -24NF-3 x 1 bolt, two $\frac{3}{8}$ -inch external tooth lock washers (one on either side of the strap) and a $\frac{3}{8}$ -24NF-3 lock washer nut to secure the ground strap in place.

j. Install the distributor; before installing the distributor, however, check the position of the groove in the end of the oil pump drive shaft. If the groove in the end of the oil pump drive shaft is not in the "final" position shown in figure 81, turn the crankshaft as necessary to cause the oil pump shaft to move to the correct position.

- (1) To install the distributor, remove the distributor cover screws and remove the cover from the distributor. Install the distributor in the engine, guiding the distributor drive shaft into the drive shaft hole in the cylinder block. If the tang on the end of the distributor drive shaft does not engage the groove in the end of the oil pump drive shaft, hold the body of the distributor and turn the distributor rotor until engagement of the shafts is completed.
- (2) Install the $\frac{1}{4}$ -20NC-2 x $\frac{5}{8}$ cap screw (UU, fig. 12) and the $\frac{1}{4}$ -inch plain washer (NN, fig. 12) to secure the distributor in place.
- (3) When the distributor has been secured in place, the distributor rotor should be in the position as shown in figure 106 (No. 1 cylinder firing position).

Note. If the rotor is in any other position, the oil pump shaft is improperly **positioned**. Refer to paragraph 101 for method of correctly positioning oil pump shaft.

- (4) Connect the distributor to withshield wiper tee vent line (M, fig. 111) to the distributor and install the distributor cover.

k. Install the carburetor insulator (XX, fig. 12) and the carburetor studs and secure in place with two $\frac{3}{8}$ -24NF-2 nuts. Connect the fuel pump to carburetor line (G, fig. 105) to the carburetor inlet connection. Install the carburetor to air cleaner pipe hose (AB, fig. 12) on the carburetor, and connect the air intake pipe vent line (H, fig. 111) and the distributor to air intake pipe vent line to their respective connectors. Connect the vent hose (K, fig. 3) oil filler pipe (J, fig. 3). Connect the throttle rod (G, fig. 97) to the carburetor throttle shaft.

l. Install the generator mounting support (H, fig. 12) and the belt tension adjusting brace (G, fig. 12) on the right side of the engine using the adjusting brace bolt (AS, fig. 12), a $\frac{3}{8}$ -inch lock washer (AM, fig. 12) and a $\frac{3}{8}$ -24NF-2 nut (AL, fig. 12) to secure the adjust-

ing brace in place. Use two $\frac{3}{8}$ -16NC-2 x $\frac{7}{8}$ cap screws (GG, fig. 12) and two $\frac{3}{8}$ -inch lock washers (HH, fig. 12) to secure the generator mounting support (H, fig. 12) in place. Install the generator as directed in TM 9-804A.

m. Install the generator, fan and water pump drive belts, moving generator away from the engine until the belts have measured deflection of $\frac{3}{4}$ -inch under a straight edge held across the generator and water pump pulleys. Tighten the belt tension adjusting brace to secure the belts in their proper position.

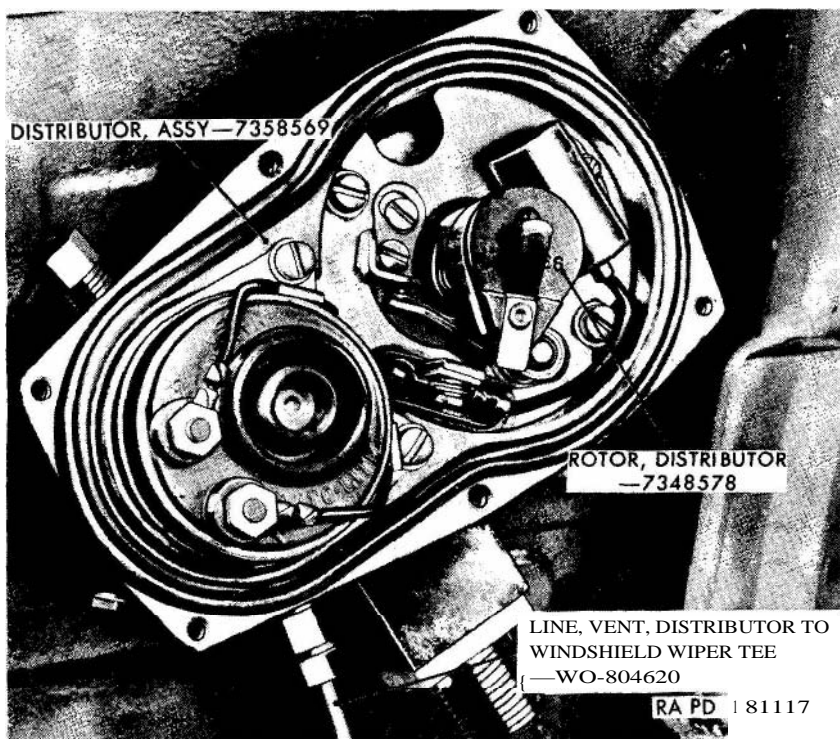

Figure 106. Number one firing position of distributor rotor.

n. Install starter support (U, fig. 12) using a $\frac{3}{8}$ -inch plain washer (X, fig. 12) and a $\frac{3}{8}$ -16NC-2 x $\frac{3}{4}$ lock washer cap screw (W, fig. 12) to secure the support in place on the engine. Coat both sides of the starter assembly gasket (AA, fig. 12) with plastic type gasket cement. Install the starter assembly (Y, fig. 12) and the gasket using a $\frac{5}{16}$ -18NC-2 x $\frac{3}{4}$ lock washer cap screw (V, fig. 12) to attach the starter to the starter support. The bolts which secure the mounting flange of the starter to the rear mounting plate and the clutch housing are not installed until the clutch housing is installed.

o. Coat both sides of the rocker arm cover gasket (X, fig. 70) with liquid type gasket cement. Pour about a quart of No. 10 engine oil

over the rocker arm parts and install the rocker arm cover (S, fig. 70) and the gasket in place on the cylinder head. Install a rocker arm cover stud gasket (T, fig. 70) on each of the rocker arm cover studs. On the front stud, install one spark plug cable clip (W, fig. 70) and two spark plug cable clips (U, fig. 70) in the relative order as shown. On the rear stud, install one spark plug cable clip (U, fig. 70). Secure the clips and the rocker arm cover in place with two $\frac{5}{16}$ -24NF-2 nuts.

p. Connect the vent hose (R, fig. 3) to the oil filler pipe (J, fig. 3) and to the rocker arm cover elbow (R, fig. 6). Install the oil level gage and cap (Q, fig. 3) into the oil filler pipe.

q. Install the spark plug annular gaskets and spark plugs (XX and AF, fig. 13). Connect the spark plug cable assemblies (AE, fig. 12) to the spark plugs and to the distributor terminals in the order shown J, K, L, M, figure 5. Snap the cables under the clips installed on the rocker arm cover attaching studs.

Section XIX. ENGINE RUN-IN TESTS AND ADJUSTMENTS

125. Preparation for Run-In

Install the engine in a dynamometer or a test stand. Pre-oil the engine by forcing oil under pressure into the oil system to insure adequate lubrication of all parts until the oil pump supply reaches them. If pre-oiling equipment is not available, fill the engine oil pan with OE-10 engine oil to the "full" mark on the oil level gage.

126. Engine Run-In

a. General. A rebuilt engine will be started and run-in in accordance with instructions given in TB ORD 215.

b. Warm-Up Run Before Adjustments. Run the engine for 15 minutes at 1,000 rpm, no load, to warm engine. Stop the engine and make adjustments (1) through (5) below :

- (1) Adjust distributor breaker point gap to 0.020-inch. Refer to TM 9-804A for procedure.
- (2) Adjust ignition timing. Refer to TM 9-804A for procedure.
- (3) Remove the spark plug cables and the rocker arm cover and check the cylinder head attaching cap screws and rocker arm shaft bracket stud nuts. If necessary, tighten the cylinder head cap screws to 60-70 pound-feet torque and the rocker arm shaft bracket nuts to 30-36 pound-feet torque.
- (4) Recheck and, if necessary, adjust the intake valve clearance (par. 114). Replace rocker arm cover and spark plug cables (par. 124o and q).
- (5) Start engine and adjust carburetor idle adjusting screw for an engine speed of 600 rpm as directed in TM 9-804A.

CHAPTER 5

CLUTCH ASSEMBLY

Section I. DESCRIPTION AND DATA

127. Description

The Borg and Beck clutch assembly is a single plate dry disk, automotive type, composed of two major units; the pressure plate with cover assembly and the driven disk with facings and hub assembly (fig. 107).

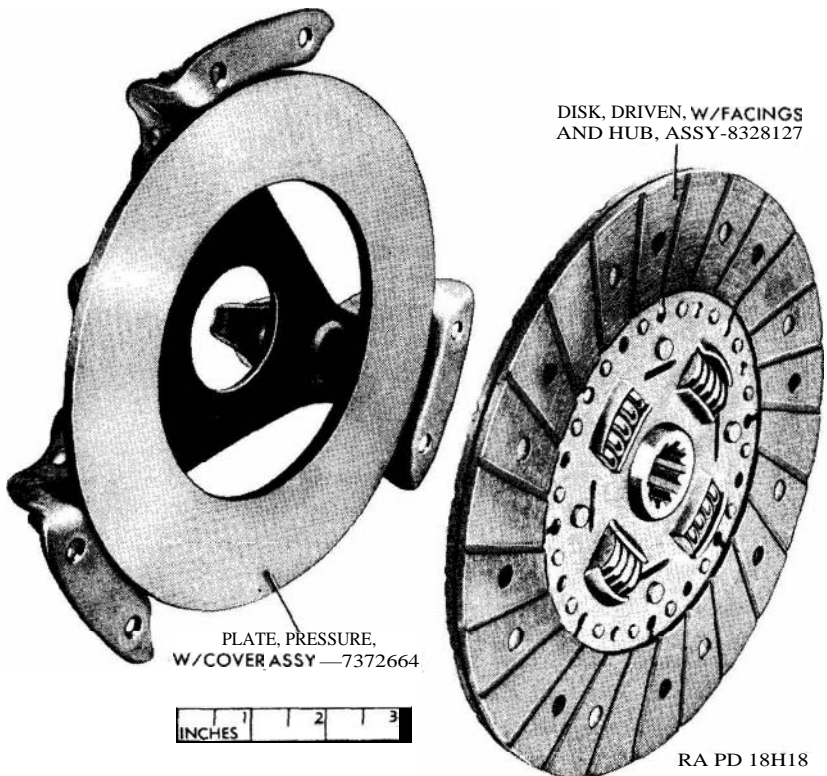

Figure 107. Major units of clutch assembly.

128. Data

Type	-----	Single dry plate
Torque capacity	-----	144 lb-ft
Clutch disk w/facings and hub assembly :		
Make	-----	Borg and Beck
Facing quantity and material	-----	Two molded asbestos
Facing diameter inside	-----	51/8-in
Facing diameter outside	-----	8½-in
Facing thickness	-----	0.138-in
Pressure plate w/cover assembly :		
Make	-----	Auburn
Number of springs	-----	6
Pressure spring pressure at 1% ₆ compressed length	-----	180 lb
Auxiliary spring pressure at 1 ³³ / ₈₄ compressed length	-----	60 lb

Section II. DISASSEMBLY OF PRESSURE PLATE WITH COVER ASSEMBLY

129. Remove Pressure Plate Cover From Pressure Plate

a. Install the pressure plate with/cover assembly (fig. 108) in an arbor press on a fiat plate large enough to support the assembly at all points. Position a length of round stock approximately 21½ inches in diameter on the pressure plate release levers so that it bears on all three levers. Remove the clips from the ends of the release levers.

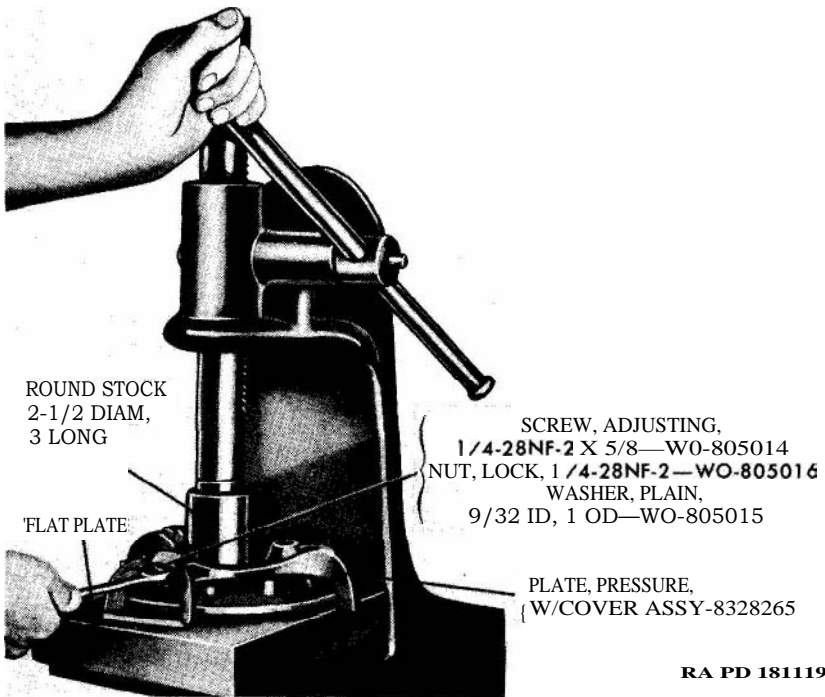

Figure 108. Depressing pressure plate release levers.

b. Exert a moderate amount of pressure on the section of round stock to depress the release levers. Remove the pressure plate release lever clips (L, *fig. 109*) from the ends of the levers.

c. Remove the adjusting screw, lock nut, and plain washer (*fig. 108*) from the pressure plate. Hold a steady pressure on the levers until all three cap screws are removed. Release the applied pressure slowly, and remove the pressure plate with/cover assembly from the arbor press when the springs have expanded to their full free length.



Figure 109. Clutch, assembly-disassembled view.

d. Remove the pressure plate spring cups (F, *fig. 109*), pressure springs (G, *fig. 109*), auxiliary pressure springs (H, *fig. 109*), and auxiliary pressure spring retainers from the pressure plate (D, *fig. 109*).

130. Remove Pressure Plate Release Levers

Inspect the pressure plate release levers and if they are found to be worn or damaged, or if the pressure plate lever pivot pin is loose, cut off one end of the pivot pin with an abrasive wheel and drive the pin out of the plate. Remove lever.

Section III. CLEANING, INSPECTION, AND REPAIR OF CLUTCH ASSEMBLY

131. Cleaning

Note. Before performing any of the operations given in this section, refer to the general instructions given in paragraphs 24 through 29, relative to the cleaning, inspection, and repair of engine parts.

Clean all parts of the clutch assembly thoroughly.

132. Inspection and Repair

(fig. 109)

a. Replace the pressure plate (D) if the plate is worn unevenly, scored, ridged, or burned. Replace the plate if the face of the plate shows radial cracks.

b. Replace any worn or damaged pressure plate release levers (K). Replace the pressure plate cover (E) if the cover is warped or distorted.

c. Inspect the driven disk, with hub assembly (B) and replace the disk if it is distorted or warped.

d. If the driven disk facings (A and C) are worn thin, torn, oil soaked, burned, or highly glazed, drill out the tubular rivets (R) and replace the facings. When installing the new facings turn the smooth (non-grooved) sides of the facings to the disk. Install the $\frac{9}{64}$ diameter, $\frac{1}{4}$ long, flat head tubular rivets (R) so that heads of alternate rivets are on the same side of the disk.

e. Replace any damaged or deformed pressure plate spring cups (F) or auxiliary pressure spring retainers (M).

f. Place each pressure spring (G) in a tester (fig. 35) and compress the spring to $1\frac{1}{6}$ -inches. If the indicator reads less than 180 pounds, replace the spring. Place each auxiliary pressure spring (H) in the tester and compress the spring to $1\frac{3}{4}$ -inches. If the indicator reads less than 60 pounds, replace the spring.

Section IV. ASSEMBLY OF PRESSURE PLATE WITH COVER ASSEMBLY

133. Install Pressure Plate Release Levers

(fig. 109)

If the pressure plate release levers (K) were removed from the pressure plate cover (E), install the levers and pressure plate release lever pivot pins (J) and rivet the pivot pins in place. Make certain the levers work freely on the pins.

134. Install Pressure Plate Cover on Pressure Plate

(fig. 109)

- a. Set the pressure plate (D) on the fiat bed of the arbor press (fig. 108) and position the pressure plate cover (E) over the plate. Lift the release levers so that they stand straight up.
- b. Install the three pressure plate spring cups (F) in the cover with the indentations in the cups facing the center of the cover.
- c. Install a pressure spring (G) and an auxiliary pressure spring (H) (auxiliary pressure spring centered in the pressure spring) in each pressure plate spring cup (F). Install an auxiliary pressure spring retainer (M) on top of each auxiliary pressure spring.
- d. Drop the levers over the ends of the springs, and center a piece of $2\frac{1}{2}$ -inch diameter, 3-inch long round stock on the levers (fig. 108). Exert a moderate pressure on the levers with the arbor press and secure the pressure plate cover to the pressure plate with a $\frac{1}{2}$ ID, 1 OD, plain washer (Q) ; a $1/4$ -28NF-2 x $5/8$ adjusting screw (N) ; and a $1/4$ -28NF-2 lock nut (P) installed under each of the pressure release levers (fig. 108).
- e. Install the pressure plate release lever clips (L) by engaging the slotted underside of the clips under the heads of the adjusting screws (N), and then snapping the clips into place over the ends of the pressure plate release levers (K).

CHAPTER 6

UNDERWATER ENGINE VENTILATING SYSTEM

Section I. DESCRIPTION AND OPERATION

135. Description

a. Ventilation of internal combustion engines is necessary to prevent harmful condensation, to relieve internal pressures set up by the action of rapidly moving parts, and to rid the crankcase section of volatile vapors. Sections requiring ventilation are usually vented directly to the atmosphere through suitable openings or vents.

b. As described in paragraphs 4f and 20b, this particular Model MD engine is of waterproof construction. Because it is waterproof, or watertight, it is also airtight. Therefore, the method used to ventilate the engine is not according to usual practice. Disregard this chapter when working on engines not equipped with the underwater ventilating system.

c. The usual method of ventilating is impractical because of the necessity of keeping the engine watertight when submerged. Thus, the Model MD engine utilizes a separate ventilating system having a single inlet connected to the engine air inlet system and a single outlet connected to the engine intake manifold. The ventilating air then passes through the combustion chambers and out through exhaust system. The system, made up of tubes, hoses, valves, etc. interconnects all the points requiring ventilation. Two other units that require ventilation, the carburetor and the distributor (fig. 111), are vented independently of the engine ventilation system (*d* below).

d. The carburetor and the distributor are vented in the following manner :

- (1) *carburetor ventilation.* The upper section of the carburetor must be open to atmospheric pressure to maintain a balanced condition in all parts of the carburetor. Therefore, the carburetor is vented by means of the vent line (H, fig. 111) which is connected to the top of the carburetor and to the air intake pipe.
- (2) *Distributor ventilation.* The distributor is vented by means of two lines : First, the distributor to windshield wiper tee vent line (M, fig. 111) connected to the underside of the distributor and to a $\frac{3}{16}$ -inch inverted flared tube special

- A —CONNECTOR, BALL-CHECK, 3 1644-7375063
—ELBOW, **90-DEG—137421**
- C —PUMP, FUEL, **ASSY—WO-807441**
- D —TEE, TUBE, INV FLARED, **5/16-IN—143483**
- E —VALVE, **METERING—5336400**
- F —LINE, VENT—WO-806359
- G —CLAMP, HOSE—WO-808407
- H —EL BOW—WO-806317**
- J —HOSE, **VENT—WO-807400**
- K —HOSE, VENT—WO-806357
- L —VALVE, VENT CONTROL, UPPER CRANKCASE-7410836
- M —ELBOW, 90-DEG—WO-807711**
- N —NIPPLE—WO-17122

- —CONNECTOR, FLARED TUBE-137406
- Q —TEE, 1/8 IN-444132**
- R —PLUG, PIPE, **1/8-IN—143932**
- S —LINE, PRESSURE—WO-807495
- T —ELBOW, INV FLARED TUBE, **3/16-IN—137420**
- U —VENT, TRANSFER **CASE—WO-801081**
- ✓ —PLUG, PIPE, **1/4-IN—143933**
- W —TEE, INV FLARED TUBE, 3/16 IN
- X —LINE, PRESSURE—WO-807700
- Y —ELBOW, FLARED TUBE, **5/16-IN—137422**
- Z —LINE, VENT—WO-806064
- AA —BODY, VENT, **CRANKCASE—WO-A6920**
- BB —VALVE, VENT CONTROL, LOWER CRANKCASE-7410836

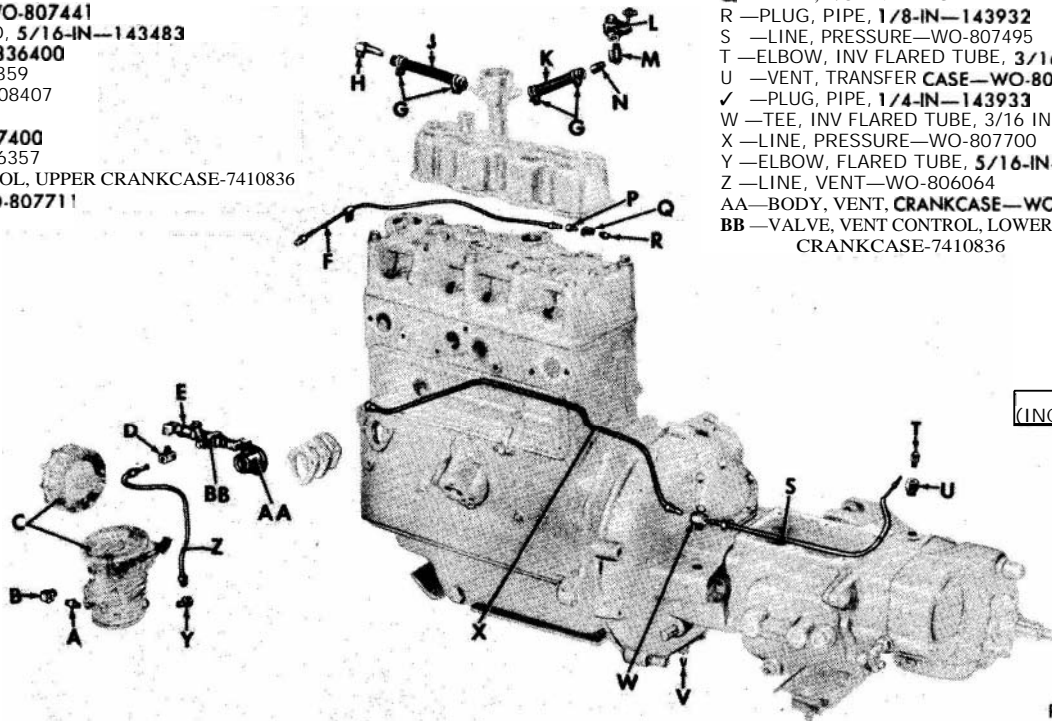

RA PD 181121

Figure 110. Engine ventilating system.

- A—LOOM, SPLIT, 3/16 X 1 —WO-AI 7745
- B—CLIP, TUBE, 5/16 IN-120522
- C—CONNECTOR, 3/16 IN, INV FLARED TUBE,
SPECIAL—WO-802265
- D—SCREW, CAP, LOCK WASHER, 1/4-20NC-2—
WO-800226**
- E—TEE, 1/4-IN, INV FLARED TUBE-1 78910
- F—LINE, TEE TO WINDSHIELD WIPER—WO-807845
- G—CARBURETOR ASSY—WO-807262

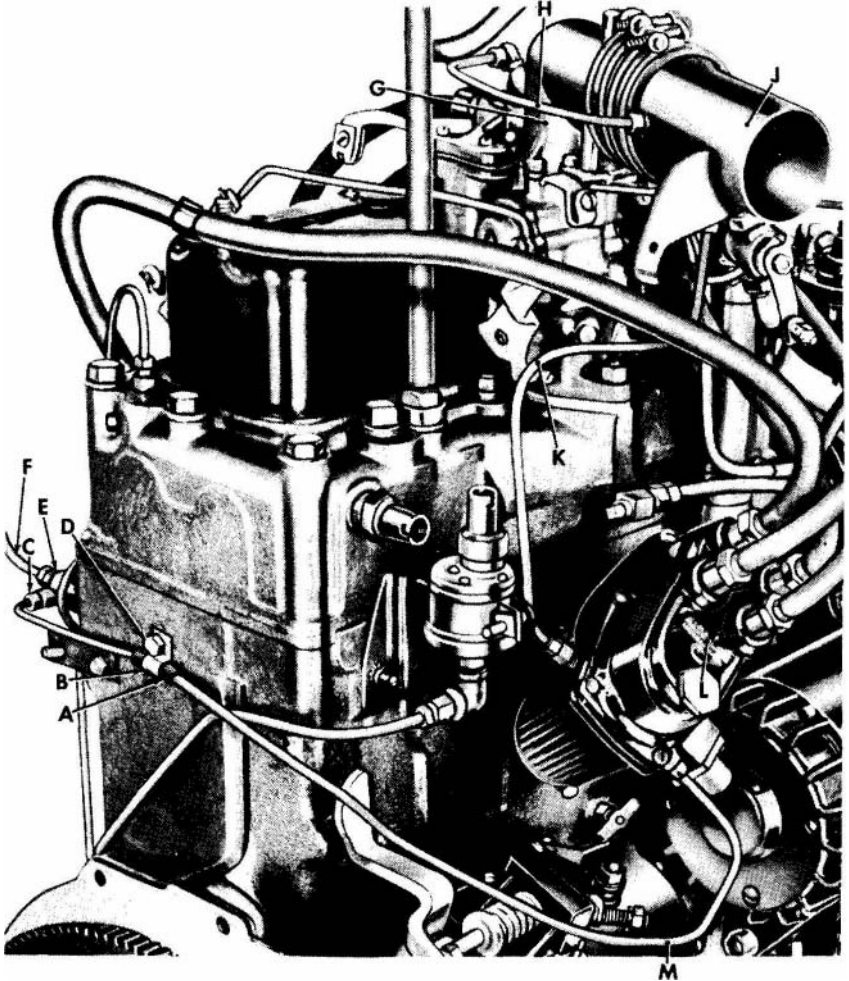

- H—LINE, VENT, CARBURETOR TO AIR INTAKE
PIPE, ASSY—WO-806447
- J—PIPE, AIR INTAKE, ASSY—WO-809246**
- K—LINE, VENT, DISTRIBUTOR TO AIR INTAKE
PIPE, ASSY—WO-806419
- I.—DISTRIBUTOR, W/COIL, ASSY-7358569
- M—LINE, VENT, DISTRIBUTOR TO WINDSHIELD
WIPER—WO-806420

RA PD 181122

Figure 111. Carburetor and distributor vent system.

connector. Second, the distributor to air intake pipe assembly vent line (K, fig. 111) connected to the upper side of the distributor and to the air intake pipe assembly. The 3/16-inch special connector is used in the distributor vent line to restrict the distributor vent line to 0.040-inch. This restriction limits the amount of vacuum in the distributor to a predetermined value regardless of the engine speed.

e. Another series of tubes and fittings connects the transfer case and the clutch housing with the center section of the fuel pump and through that to the crankcase section of the engine (par. 137e). Although not used to ventilate the engine, this series of tubes is considered part of the engine ventilating system because it is through these tubes that the clutch housing, the transmission, and the transfer case are pressurized, and thus protected, against the entry of water during underwater operation.

136. Operation (Over-Land Service)

(fig. 110)

a. When the engine is running, the vacuum created in the engine intake manifold and the vacuum booster section of the fuel pump (C) draws fresh air into the ventilating system through the upper crankcase vent control valve (L) attached to the air intake pipe assembly (J, fig. 111). The flow of air is then through the 90° elbow (M), the nipple (N), and the vent hose (K) to the oil filler pipe. From the oil filler pipe, the air passes through the vent hose (J), and the elbow (H) to the rocker arm cover mounted on the cylinder head. From the area inclosed by the rocker arm cover, the air passes downward into the cylinder block or crankcase, through the intake valve push rod openings. The air leaves the cylinder block through the series of closely assembled parts which include the lower crankcase vent control valve (BB) and the metering valve (E). The air is then exhausted into the engine intake manifold through the vent line (F), flared tube connector (P), and 1/8-inch tee (Q). From the air intake manifold the air is drawn into the cylinders, burned, and then exhausted into the engine exhaust system. The vent line (Z) connects the vacuum booster section of the fuel pump to the engine ventilating system to insure a constant vacuum in the engine ventilating system regardless of the engine speed.

b. When the vehicle is in over-land service, the two vent control valves, (L and BB), are open and play no part in the ventilating system. The metering valve (E) , however, operates to automatically control or limit the amount of vacuum developed within the engine ventilating system to a predetermined value regardless of the engine speed, as follows :

- (1) At high engine speeds, the air in the engine ventilating system is moving at a relatively high velocity, a condition which causes the metering valve (*fig. 112*) to be pulled forward against the seat in the metering valve body. As long as high engine speed and high air velocity is maintained, the Valve

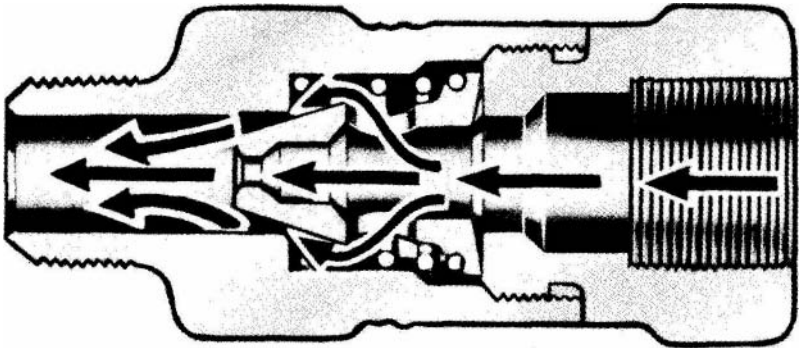

VALVE OPEN

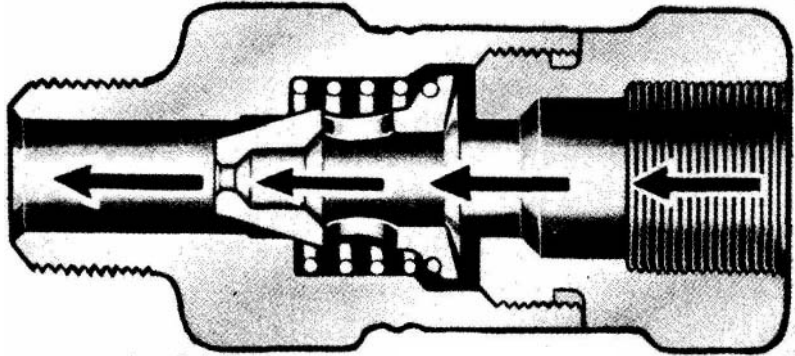

RA PD 181123

VALVE CLOSED

Figure 112. Sectional view of ventilating system metering valve.

will remain in this position and only the air that can pass through the restricted opening in the center of the valve will be drawn into the intake manifold.

- (2) As the engine speed and velocity of the air in the ventilating system decreases, the pressure of the metering valve spring forces the valve away from the seat in the metering valve body and an increased volume of lower velocity air can then pass through the metering valve.

37. Operation (Underwater Service)

(fig. 110).

a. Prior to entering the water, the vehicle operator installs the $\frac{1}{4}$ -inch pipe plug (V) in the drain opening in the clutch housing and closes the two vent control valves (L and BB).

b. The closing of the vent valves renders the entire engine ventilating system inoperative.

Note. This does not include the vent system of the carburetor and the distributor which are vented independently of the engine (par. 135d).

When the vent control valves are closed with engine running, the unrelieved pressure within the engine builds up to approximately 2-psi. Internal pressure rarely goes higher than 2-psi because, at higher pressure, leakage occurs through the crankshaft front and rear oil seals. This internal pressure offsets the external pressure of the water surrounding the engine and effectively prevents the entry of water into the engine past imperfectly sealed joints or through the front or rear oil seals.

c. The engine high internal pressure is also used to pressurize the clutch housing and transfer case and is conducted to the clutch housing, transmission, and the transfer case through a series of lines and fittings (2) below). The purpose in raising the internal pressure of these units is to give them the same protection against the entry of water that is given the engine.

Note. There is no direct pressure line connection to the transmission case because there is a common internal opening between the transmission and the transfer case through which the pressure reaches the transmission.

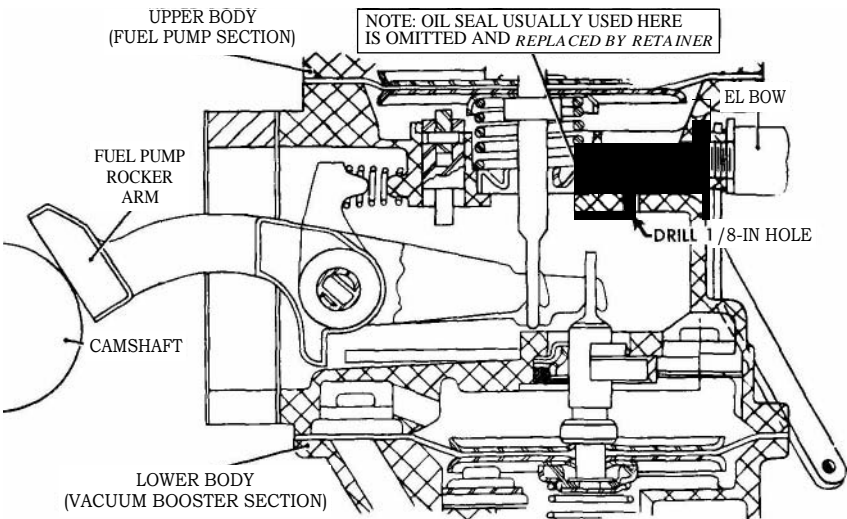

RA PD 1811 94

Figure 113. Sectional view of fuel pump assembly.

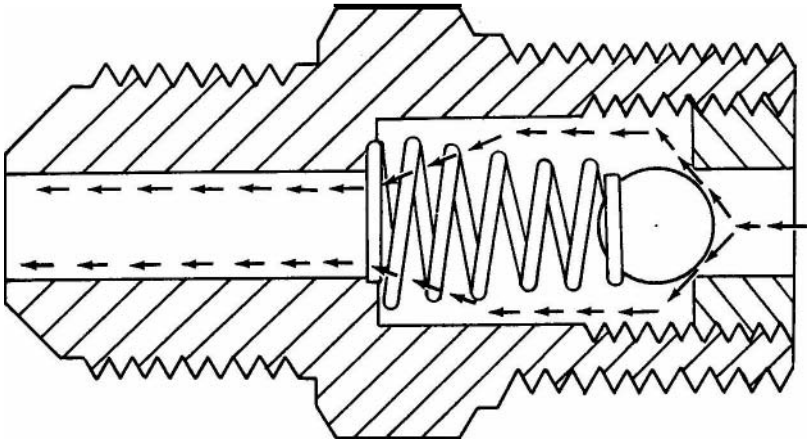

BALL CHECK CONNECTOR—VALVE OPEN

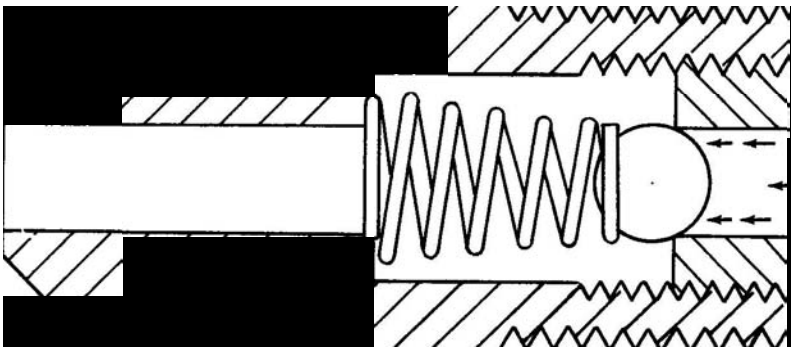

RA PD 181125

BALL CHECK CONNECTOR—VALVE CLOSED

Figure 114. Ball check connector—sectional view.

The high pressure is conducted to the clutch housing and the transfer case in the following manner :

- (1) The pressure developed in the engine crankcase backs up into the center section of the fuel pump through the fuel pump rocker arm opening in the cylinder block. The pressure then travels upward in the fuel pump into the space directly below the upper diaphragm shaft.

Note. To facilitate pressurizing of the clutch housing and transfer case, two modifications have been made in the fuel pump assembly. The oil seal normally used in the fuel pump .at the location indicated in figure 113 is omitted, and a $\frac{1}{2}$ -inch hole is drilled through the center of the fuel pump body web (fig. 113).

(2) From the fuel pump the pressure path is to the clutch housing through the 90° elbow (B), the $\frac{3}{16}$ -inch ball check connector (A), the pressure line (X), the $\frac{3}{16}$ -inch inverted flared tube tee (W), the pressure line (S), the $\frac{3}{16}$ -inch inverted flared tube elbow (T), and the transfer case vent (U). The ball check connector is normally in the closed position and only opens when the engine internal pressure builds up above atmospheric pressure and forces the ball away from its seat in the connector.

d. When the vehicle emerges from water, the operator removes the pipe plug (V) from the bottom of the clutch housing and opens the two vent control valves (L and BB) and thereby makes the engine ventilating system again operative.

Section II. REBUILD OF ENGINE VENTILATING SYSTEM

138. Disassembly of Ventilating System

(fig. 115)

a. In the process of disassembling the engine, the ventilating system is disassembled and almost completely broken down into its individual parts. The only parts that remain to be disassembled are the upper and lower crankcase vent control valves (L and BB, fig. 110), the metering valve (E, fig. 110), and the ball check connector (A, fig. 110). The metering valve and the lower crankcase vent control valve are separated as follows:

- (1) Back the reducing elbow (A) off the threaded end of the metering valve seat (B). Remove the metering valve by unscrewing the *metering* valve base (E) from the pipe nipple (F).
- (2) Unscrew and separate the crankcase vent body (M) from the street elbow (L). Separate the two street elbows (L) and (K) and remove elbow (K) from the nipple (J). Do not remove pipe nipple (J), reducing pipe bushing (H) or pipe nipple (F) from the lower crankcase vent control *valve* body (G) unless the parts are damaged.

b. Disassemble the metering valve by unscrewing the metering valve base (E) from the metering valve seat (B) and lift the metering valve (D) and the metering valve spring (C) from the seat.

c. Disassemble the lower crankcase vent control valve as follows:

- (1) Remove the lock nut (S), the lock washer (R) and the lower crankcase vent control valve lever (V) from the end of the lower crankcase vent control valve sleeve (N). Pull the cotter pin (X) from the end of the lower crankcase vent control valve swivel pin (U) and remove the pin and flat washer (W) from the lever.

- (2) Remove the lower crankcase vent control valve packing nut (Q) and the lower crankcase vent control valve packing (P) from the lower crankcase vent control valve body (G). Lift the lower crankcase vent control valve sleeve (N) from the body.

NOTE: PARTS B, C, D, AND E
ARE PART OF METERING
VALVE ASSY—WO-A-6895

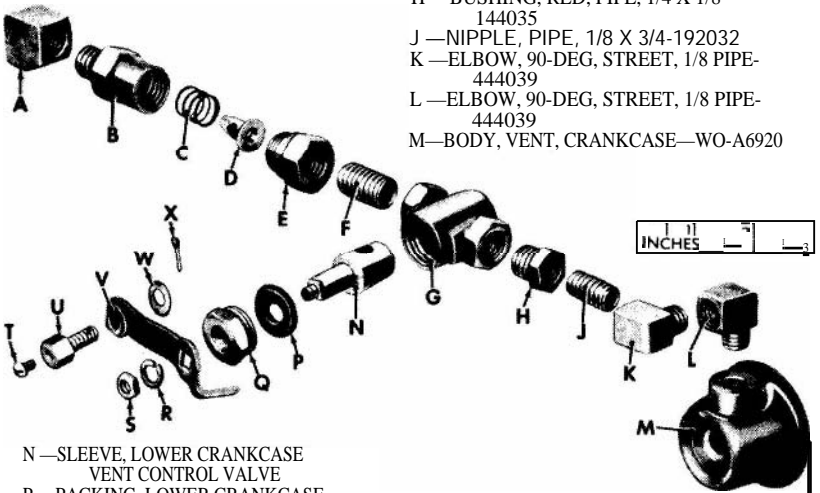

- A—ELBOW, REDUCING, 90 DEG
B—SEAT, METERING VALVE
C—SPRING, METERING VALVE
D—VALVE, METERING
E—BASE, METERING VALVE
F—NIPPLE, PIPE, 1/4 X 7/8-192050
G—BODY, LOWER CRANKCASE VENT
CONTROL VALVE
H—BUSHING, RED, PIPE, 1/4 X 1/8—
144035
J—NIPPLE, PIPE, 1/8 X 3/4-192032
K—ELBOW, 90-DEG, STREET, 1/8 PIPE-
444039
L—ELBOW, 90-DEG, STREET, 1/8 PIPE-
444039
M—BODY, VENT, CRANKCASE—WO-A6920

- N—SLEEVE, LOWER CRANKCASE
VENT CONTROL VALVE
P—PACKING, LOWER CRANKCASE
VENT CONTROL VALVE
Q—NUT, PACKING, LOWER CRANKCASE
VENT CONTROL VALVE
R—WASHER, LOCK
S—NUT, LOCK
T—SCREW, RD-HD, NO 6-32NC-2 X 3/16
— 132684
U—PIN, SWIVEL, LOWER CRANK-
CASE VENT CONTROL VALVE
V—LEVER, LOWER CRANKCASE VENT
CONTROL VALVE
W—WASHER, FLAT-120391
X—PIN, COTTER, 1/16 X 3/8-119981

NOTE: PARTS G, N, P, Q, R, S,
T, U, V, W, AND X ARE PART OF
LOWER CRANKCASE VENT CONTROL
VALVE ASSY—WO-804277

RA PD 181126

Figure 115. Ventilating system parts (exhaust valve spring compartment cover to intake manifold line).

d. Unscrew the upper crankcase vent control valve (fig. 116) and remove the valve from the air intake pipe (fig. 116). Remove the coupling (fig. 116) and the elbow (fig. 116) from the valve. The upper and lower crankcase vent control valves are identical. Disassemble the valve following the instructions given for disassembling the lower crankcase vent control valve in (c above).

e. Remove the ball check connector from the fuel pump and disassemble connector (fig. 114) as follows:

- (1) Back the connector seat out of the connector body.
- (2) Remove the ball check and ball check spring from the connector body.

139. Cleaning, Inspection, and Repair of Ventilating System

Parts

Note. Before performing any of the operations given in this section, refer to the general instructions given in paragraphs 24 through 29, relative to the cleaning, inspection, and repair of engine parts.

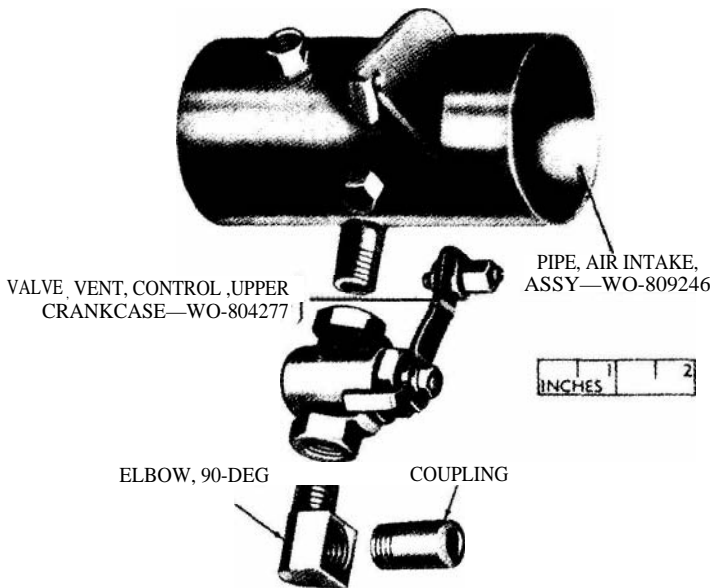

RA PD 181127

Figure 116. Ventilating system parts (air inlet pipe to rocker arm cover).

- a. Clean all parts of the engine ventilating system.
- b. Normally there is no wear of the parts of the ventilating system. The parts need only be inspected for damage and to make sure that all holes and openings are open and clear. Any damaged part or parts with rough threads must be replaced.

140. Assembly of Ventilating System

(fig. 115)

a. Figures 115 and 116 show the relative location of the various parts of the ventilating system. Use these illustrations as a guide when assembling the ventilating system.

b. When assembling the parts of the ball check connector (fig. 114) screw the seat into the connector body until the end of the seat is just flush with the end of the connector body. Clamp the connector in a bench vise and using a small, sharp punch, tap lightly against the inside edges of the connector body opposite the slot in the end of the seat, and wedge a little of the connector body metal into the slot.

Note. Take care not to damage the threads on either piece. These pieces are brass and only a very light tap is required to satisfactorily perform the operation.

c. Assemble the lower crankcase vent control valve as follows:

- (1) Insert the lower crankcase vent control valve sleeve (N) into the lower crankcase vent control valve body (G). Install new lower crankcase vent control valve packing (P) over the end of the sleeve and secure in place with the vent control valve packing nut (Q). Tighten the packing nut until the sleeve is seated firmly in the valve body.
- (2) Install the lower crankcase vent control valve lever (V) on the end of the sleeve (N) and secure in place with the lock washer (R) and lock nut (S). Install the swivel pin (U) in the end of the lever and secure in place by installing the flat washer (W) and $\frac{1}{16} \times \frac{3}{8}$ cotter pin (X).

d. The upper crankcase vent control valve is identical to the lower crankcase vent control valve and is to be assembled by following the instructions given in c above.

e. Assemble the metering valve (D) as follows:

- (1) Install the metering valve spring (C) and the metering valve (D) in the metering valve seat (B) with the conical end of the valve facing the externally threaded end of the seat.
- (2) Coat the external threads of the metering valve base (E) with plastic type gasket cement and press the base into the seat.

f. Assemble the metering valve and the vent control valve together and to the other related lower crankcase ventilating system parts in the order shown in figure 115. Coat the external threads of all parts with plastic type gasket cement before assembling them together.

g. Coat the external threads of the upper crankcase vent system related parts (fig. 116) with plastic type gasket cement and install the 90° elbow in the vent control upper crankcase valve. Install the coupling in the elbow and complete the operation by assembling the vent control valve to the air intake pipe.

CHAPTER 7

REPAIR AND REBUILD STANDARDS

141. General

The repair and rebuild standards included herein give the minimum, maximum, and key clearances of new or rebuilt parts as well as wear limits which indicate that point to which a part or parts may be worn before replacement, in order to receive maximum service with minimum replacement. Normally, all parts which have not been worn beyond the dimensions shown in the "Wear Limits" column or damaged from corrosion *will* be approved for service.

142. Cylinder Block

(pars. 50 and 51)

(All dimensions in inches unless otherwise noted.)

a. Piston Bores.

Fig. Ref. letter	Point of measurement	<i>Sites and fits of new parts</i>		<i>Wear limits</i>
		<i>Minimum</i>	<i>Maximum</i>	
117 X	Diameter at top of ring travel -----	3. 125	3. 127	3. 137
M	Diameter at bottom of ring travel ----	3. 125	3. 127	3. 129
U	Piston to block clearance -----	0. 0021	0. 0029	0. 005
	Rebore for next oversize at -----		-----	0. 005
	Max taper -----		-----	0. 010
	Out of round -----	0. 0003	0. 0005	0. 003

b. Valve Tappet Bores.

118 A	Diameter of tappet bore -----	0. 625	0. 626	0. 6295
B	Tappet to block clearance -----	0. 0005	0. 002	0. 003
	Rebore for oversize at -----		-----	0. 003

Note. Valve tappets are available in 0.004-inch oversize.

c. Exhaust Valve Guide Bores.

119 B	Diameter -----	0. 655	0. 656
-------	----------------	--------	--------

d. Exhaust Valve Seats.

119 E	Exhaust valve seat angle -----	45°
-------	--------------------------------	-----

e. Camshaft Bores.

117 J	Front bushing type bearing -----	2. 1870	2. 1880
	Front intermediate -----	2. 1250	2. 1260
N	Rear intermediate -----	2. 0625	2. 0635
P	Rear -----	1. 6250	I. 6260

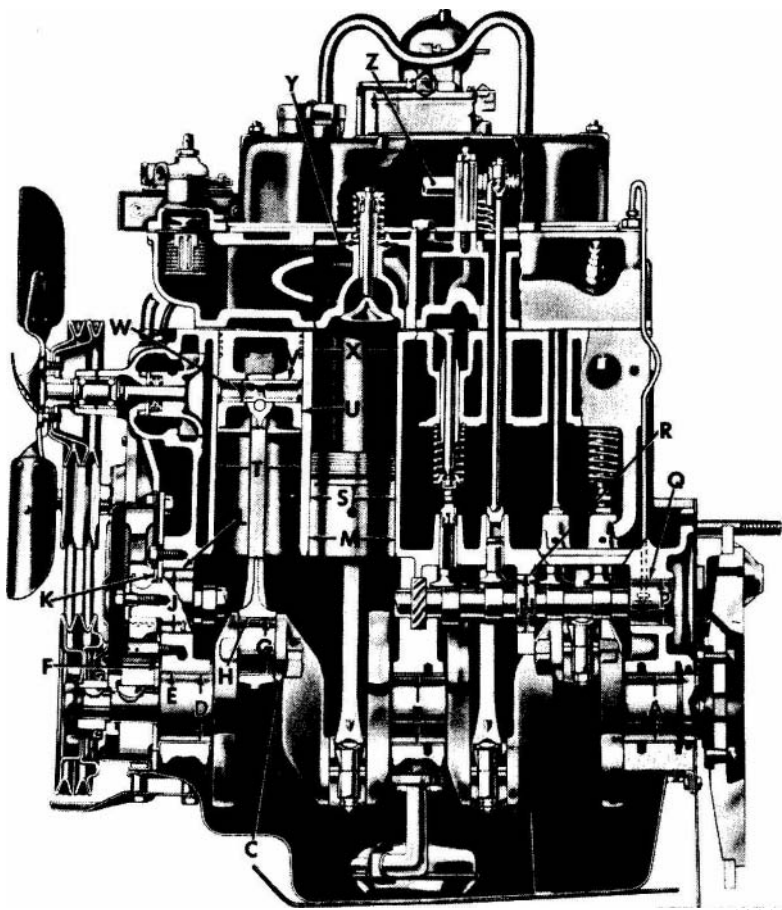

RA PD 181128

Figure 117. Repair and rebuild standards points of measurement.

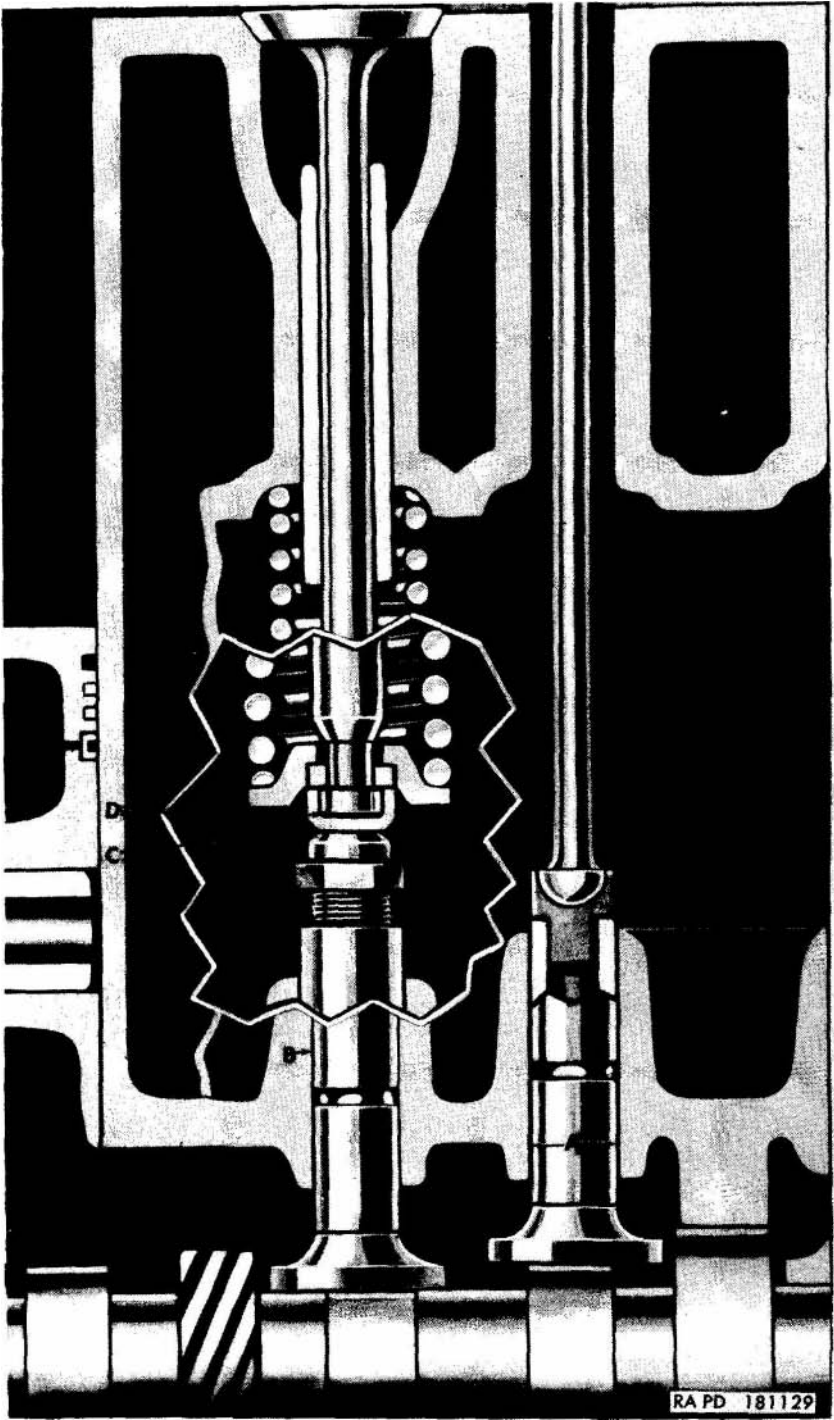

Figure 118. Repair and rebuild standards points of measurement.

324309 0 - 55 - 11

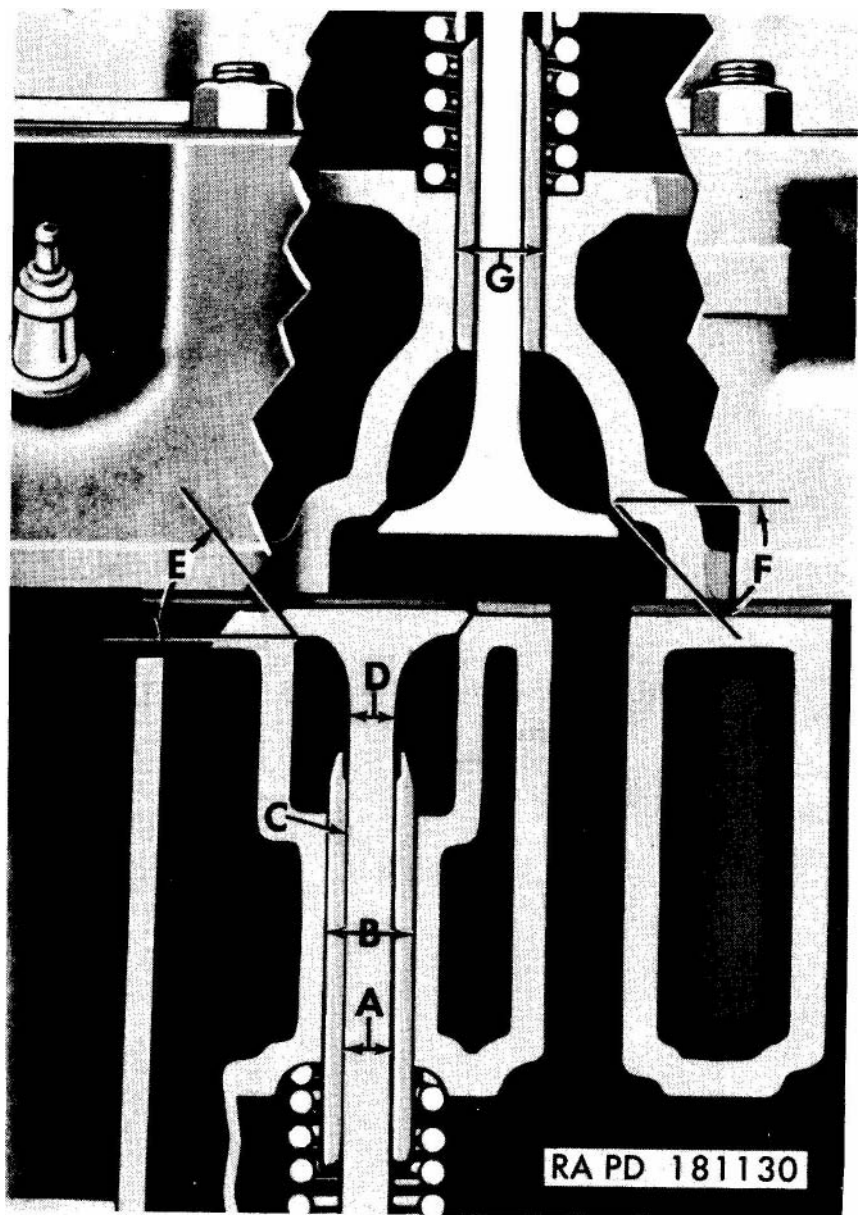

Figure 119. Repair and rebuild standards points of measurement.

143. Crankshaft

(pars. 64 and 65)

a. Crankshaft.

Fig. Ref. letter	Point of measurement	Sizes and fits of new parts		Wear limits
		Minimum	Maximum	
117	Run-out-(crankshaft suspended at points D and A).			0.001
F	End play	0.004	0.006	

b. Main Bearing Journals.

117	D B A Diameter	2.332	2.3340	2.3330
E	Bearing to journal clearance	0.001	0.002	0.001 to 0.0025
	B A Re grind for next undersize at			2.3:330
D B A	Maximum out of round			0.001
D B A	Maximum taper			0.001

c. Connecting Rod Bearing Journals.

117	G Diameter	1.9370	1.9385	1.9367
H	Bearing to journal clearance	0.001	0.002	0.002
G	Re grind for next undersize at			1.9367
G	Maximum out of round			0.002
G	Maximum taper			0.002

144. Cylinder Head

(par. 54)

a. Intake Valve Guide Bores.

Fig. Ref. letter	Point of measurement	Sizes and fits of new parts		Wear limits
		Minimum	Maximum	
119	G Diameter of bore	0.655	0.656	

b. Intake Valve Seats.

119	F Valve seat angle			45°
-----	--------------------	--	--	-----

145. Rocker Arm Assembly

(par. 57)

Fig. Ref. letter	Point of measurement	Sizes and fits of new parts		Wear limits
		Minimum	Maximum	
120	Diameter of bore in rocker arm shaft bracket.	0.7445	0.7455	
E	Bore to shaft clearance	0.0005	0.002	
117	Diameter of rocker arm shaft	0.7435	0.7440	
121	A Diameter of internal bore of rocker arm.	0.7445	0.7450	
B	Width of rocker arm	1.000		

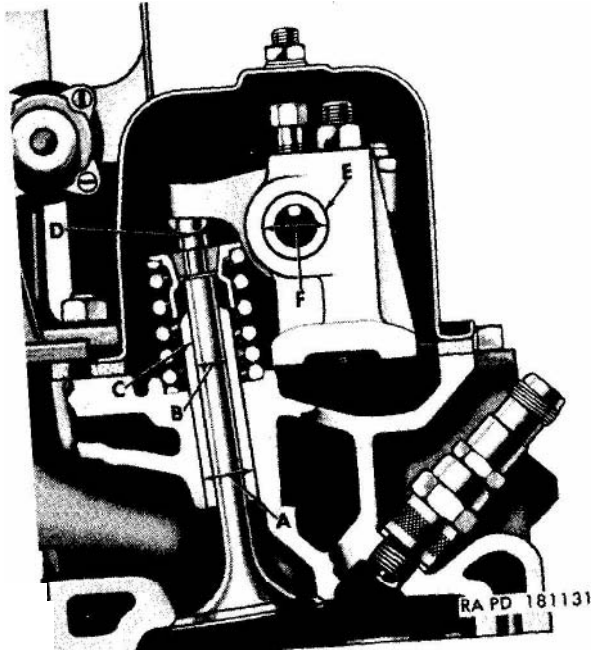

Figure 120. Repair and rebuild standards *points of measurement.*

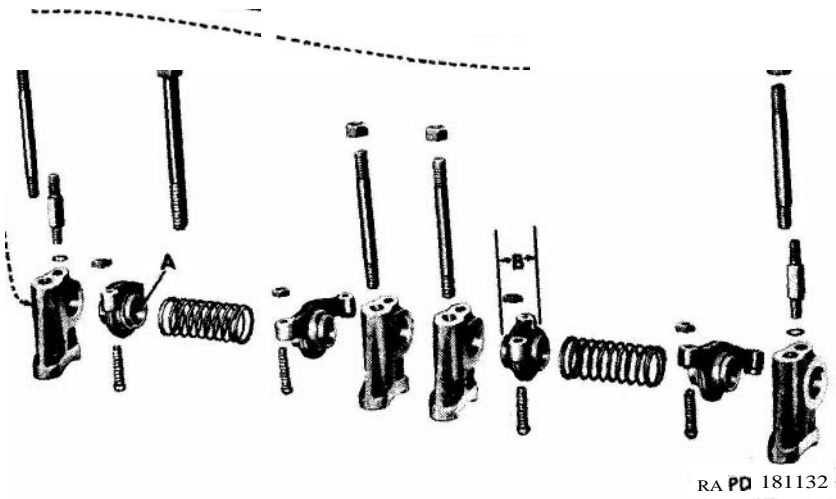

Figure 121. Repair and rebuild standards *points of measurement.*

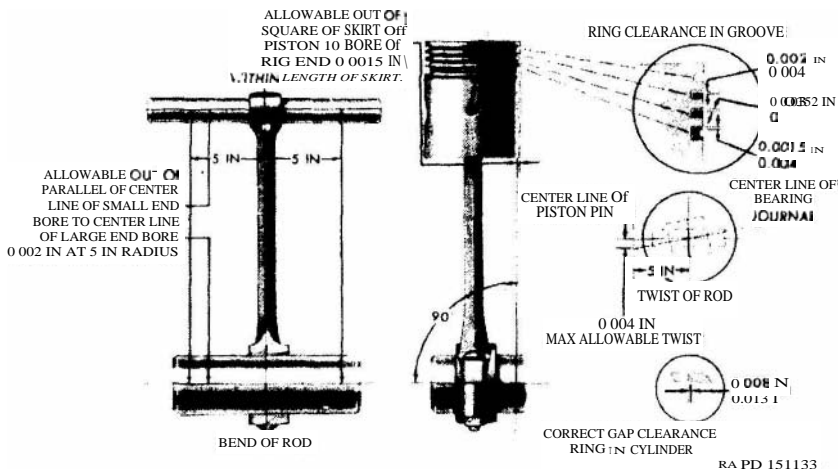

Figure 122. Repair and rebuild standards points of measurement.

146. Connecting Rod

(par. 60)

Fig. Ref. letter	Point of measurement	Sizes and fits of new parts		Wear limits
		Minimum	Maximum	
117	C Side clearance_	0.005	0.009	0.013
122	Allowable twist at 5 inches		-----	0.004
	Allowable bend			0.002

147. Pistons and Rings

(pars. 60 and 61)

a. Pistons.

Fig. Ref. letter	Point of measurement	Sizes and fits of new parts		Wear limits
		Minimum	Maximum	
117	S Diameter of piston at top of skirt (90° to piston pin).	3.1245	3.1249	
	M Diameter of piston at bottom of skirt (90° to piston pin).	3.1245	3.1249	
	U Piston to block clearance_		0.003	0.005

b. Rings.

123	C Thickness of compression rings (2) -----	0.0925	0.0935	
	B Thickness of oil ring (1) -----	0.186	0.1865	
122	Top ring to groove clearance	0.002	0.004	0.005
	Center ring to groove clearance -----	0.0015	0.0035	0.0045
	Bottom ring to groove clearance -----	0.001	0.0025	0.0045
	Ring gap in cylinder block -----	0.0008	0.013	0.020

c. Piston Pin Bores.

123	A Diameter -----	0.8120	0.8122	0.8137
	Ream for 0.003 inch oversize pin to_ _ _	0.8150	0.8152	0.8167
117	V Pin to piston clearance -----	0.0001	0.0005	0.001

d. Piston Pin.

Fig. Ref. letter	Point of measurement	Sizes and fits of new parts		Wear limits
		Minimum	Maximum	
117	W Diameter -----	0. 8117	0. 8119	
✓	Pin to piston clearance -----	0. 0001.	0. 0005	0. 001

Note. Piston pins are available in 0.003-inch oversize.

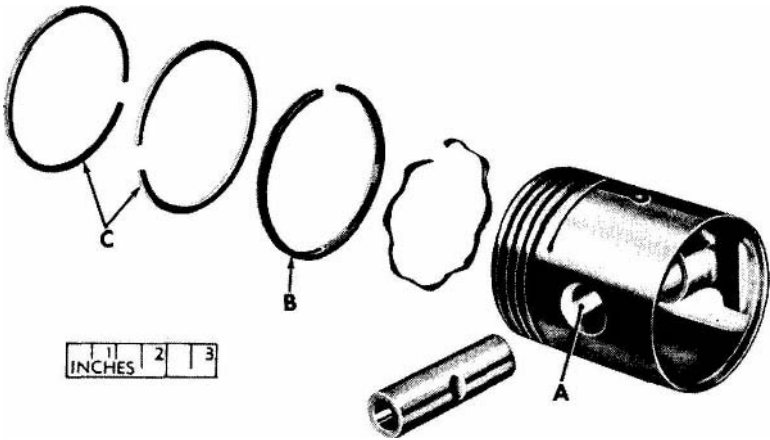

RA PD 181134

Figure 123. Repair and rebuild standard points of measurement.

148. Camshaft

(pars. 66 and 67).

a. Camshaft.

Fig. Ref. letter	Point of measurement	Sizes and fits of new parts		Wear limits
		Minimum	Maximum	
124	----- Runout (camshaft supported at A and C).			0. 001
K	Camshaft gear to thrust plate clearance.	0. 004	0. 006	0. 004

b. Bearing Journal Diameters.

124	A Front -----	2. 1855	2. 186	2. 182
	B Front intermediate -----	2. 1215	2. 1225	2. 121
	C Rear intermediate -----	2. 0590	2. 0600	2. 0585
	D Rear -----	1. 6225	1. 623	1. 621

c. Bearing to Journal Clearances.

117	L Front -----	0. 001	0. 0025	0. 004
	Front intermediate -----	0. 0025	0. 0045	0. 004
	R Rear intermediate -----	0. 0025	0. 0045	0. 004
	Q Rear -----			

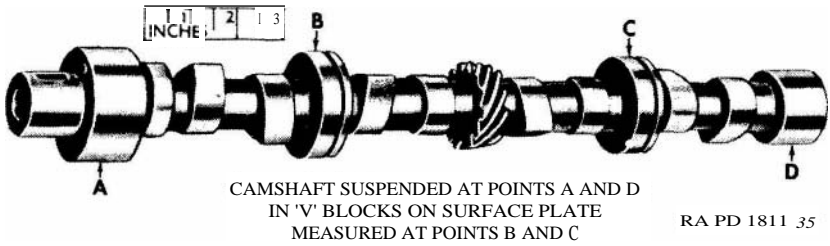

Figure 124. Repair and rebuild standards points of measurement.

149. Intake Valve

(par. 54)

a. Valves.

Fig. Ref. letter	Point of measurement	Sizes and fits of new parts		Wear limits
		Minimum	Maximum	
119	F	Seat angle -----		45°
		Diameter stem -----	0. 3733	0. 3738
120	D	Valve to rocker arm clearance	0. 018	0. 020

b. Intake Valve Guides.

120	B	Inside diameter -----	0. 3745	0. 3755	0. 3785
	C	Valve to guide clearance -----	0. 0007	0. 0022	0. 095
	A	Outside diameter -----	0. 6565	0. 6575	-

150. Exhaust Valve

(pars. 87 and 106)

a. Valves.

Fig. Ref. letter	Point of measurement	Sizes and fits of new parts		Wear limits	
		Minimum	Maximum		
119	E	Seat angle -----		45°	
	D	Diameter stem -----	0. 371	0. 372	0. 3685
118	C	Valve cap to tappet clearance	0. 016	0. 017	
	D	Valve to valve cap clearance	0. 000	0. 004	0. 005

b. Exhaust Valve Guides.

119	A	Inside diameter	0. 3745	0. 3755	0. 3785
	C	Valve to guide clearance ----	0. 0025	0. 0045	0. 0105
	B	Outside diameter -----	0. 6565	0. 6575	-

151. Oil Pump

(pars. 78 and 79)

Fig. Ref. letter	Point of measurement	Sizes and fits of new parts		Wear limits	
		Minimum	Maximum		
125	D	Outer rotor lobe to inner rotor lobe clearance.	0. 0005	0. 006	0. 010
	A	Outer rotor to pump body clearance	0. 005	0. 010	0. 012
	C	Free length of plunger spring -----		1. 640	
		Plunger spring length when load of 9% lb applied.	1. 064		
	B	End of body to end of drive gear teeth	0. 020	0. 030	

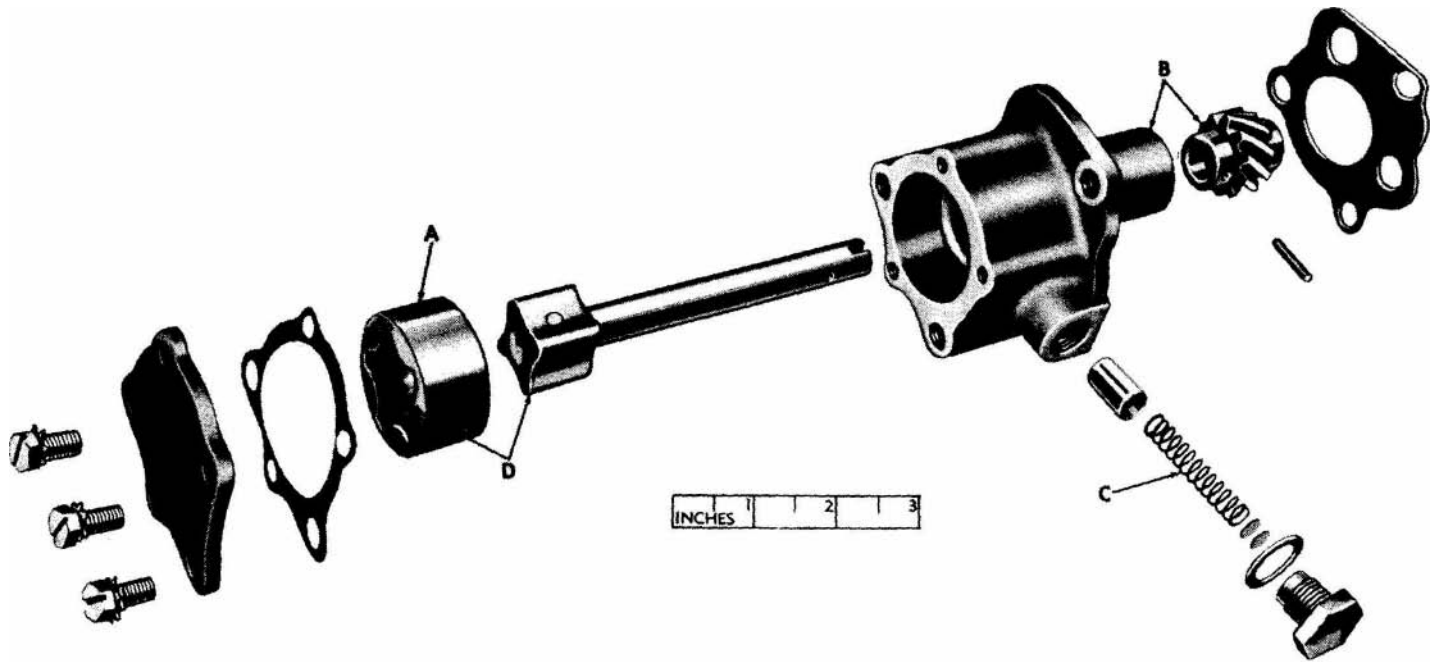

RA PD 181136

Figure 125. Repair and rebuild standards points of measurement.

152. Torque Specifications

<i>Application</i>	<i>Torque in pound-feet</i>
Camshaft gear to camshaft, bolt - - - - -	30-40
Camshaft thrust plate bolts, 4 cylinder - - - - -	20-26
Connecting rod cap bolt nut, $\frac{7}{16}$ -inch - - - - -	50-55
Cylinder head screws - - - - -	60-70
Exhaust manifold - - - - -	29-35
Flywheel to crankshaft - - - - -	35-41
Generator (bracket) - - - - -	25-35
Main bearing caps - - - - -	65-75
Oil pan screws to cylinder block - - - - -	12-17
Piston pin lock bolts, $\frac{3}{8}$ -inch - - - - -	35-41
Rocker arm bracket to head nut - - - - -	30-36
Spark plugs to cylinder head - - - - -	26-30
Starter - - - - -	20-25
Water outlet elbow to cylinder head - - - - -	20-25
Water pump to cylinder block - - - - -	12-17

APPENDIX

REFERENCES

1. Publication Indexes

Special Regulations in the 310-20 series, SR 110-1-1, ORD 1, and FM 21-8, and SB 9-1 should be consulted frequently for latest changes or revisions of references given in this appendix and for new publications relating to materiel covered in this manual.

2. Supply Manuals

The following supply manuals of the Department of the Army supply manual pertain to this materiel :

a. Destruction to Prevent Enemy Use.

Land Mines and Components ; Demolition Explosives ORD 3 SNL R-7
and Related Items ; Ammunition for Simulated
Artillery, Booby Trap, Hand Grenade, and Land
Mine Fire.

b. Repair and Rebuild.

Antifriction Bearings and Related Items ----- ORD 5 SNL H-12
Cleaners, Preservatives, Lubricants, Recoil Fluids, ORD 3 SNL K-1
Special Oils, and Related Maintenance Materials.
Electrical Fittings ----- ORD 5 SNI. H-4
Items of Soldering, Metallizing, Brazing, and Welding (ORI) 3 SNL K-2
Materials ; Gases and Related Items.
Lubricating Equipment, Accessories, and Related Dis- ORD (*) SNL K-3
pensers.
Lubricating Fittings, Oil Filters, and Oil Filter Ele- ORD 5 SNL H-16
ments.
Major Items and Major Combinations of Group G ---- ORD 3 SNL G-1
Miscellaneous **Hardware** ----- ORD 5 SNL H-2
Oil Seals ----- ORD 5 SNL H-13
Pipe and Hose Fittings ----- (ORI) 5 SNL H-6
Standard Hardware ----- ORD 5 SNL H-1
Truck, Utility, $\frac{1}{4}$ -ton 4 x 4 **M38A1** ----- ORD 8 SNL G758

3. Forms

The following forms pertain to this materiel :

DA Form 9-1, Material Inspection Tag
DA Form 9-3, Processing Record for Storage and Shipment (Tag)
DA Form 9-4, Vehicular Storage and Servicing Record (Card)

*) See SR 310-20-29, for published manuals of the ordnance section of the Department of the Army supply manual.

DA Form 9-68, Spot Check Inspection Report for Wheeled and Half-Track Vehicles
 DA Form 9-69, Spot Check Inspection Report for all Full-Track and Tank-Like Wheeled Vehicles
 DA Form 9-71, Locator and Inventory Control Card
 DA Form 9-72, Ordnance Stock Record Card
 DA Form 9-76, Request for Work Order
 DA Form 9-77, Job Order Register
 DA Form 9-78, Job Order
 DA Form 9-79, Parts Requisition
 DA Form 9-80, Job Order File
 DA Form 9-81, Exchange Part or Unit Identification Tag
 DA Form 447, Turn-In Slip
 DA Form 460, Preventive Maintenance Roster
 DA Form 461, Preventive Maintenance Service and Inspection for Wheeled and Half-Track Vehicles
 DA Form 462, Preventive Maintenance Service and Inspection for Full-Track Vehicles
 DA Form 446, Issue Slip
 DA Form 468, Unsatisfactory Equipment Report
 DA Form 378, MWO and Major Unit Assembly Replacement Record—Organizational Equipment File
 DA Form 811, Work Request and Job Order
 DA Form 811-1, Work Request and Hand Receipt
 DA Form 865, Work Order
 DA Form 866, Consolidation of Parts
 DA Form 867, Status of Modification Work Order
 DD Form 6, Report of Damaged or Improper Shipment
 DD Form 317, Preventive Maintenance Service Due (Sticker)
 OO Form 5825, Artillery Gun Book

4. Other Publications

The following publications contain information pertinent to this materiel and associated equipment:

a. Camouflage.

Camouflage, Basic Principle ----- FM 5-20
 Camouflage of Vehicles ----- FM 5-20B

b. Decontamination.

Decontamination ----- TM 3-220
 Defense Against Chemical Attack ----- FM 21-40

c. Destruction to Prevent Enemy Use.

Explosives and Demolitions ----- FH 5-25
 Ordnance Service in the Field ----- FM 9-5

d. General.

Accident Reporting_ ----- SR 385-10-40
 Cooling Systems : Vehicles and Powered Ground Equipment_ TM 9-2858

Inspection of Ordnance Materiel in the Hands of Troops	TM 9-1100
Military Vehicles	TM 9-2800
Motor Vehicles	AR 700-105
Ordnance Maintenance and General Supply in the Field	FM 9-10
Precautions in Handling Gasoline	AR 850-20
Prevention of Motor Vehicle Accidents	SR 385-155-1
Principles of Automotive Vehicles	TM 9-2700
Storage Batteries, Lead-Acid Type	TM 9-2857
Unsatisfactory Equipment Report	SR 700-45-5

e. Repair and Rebuild.

Abrasives, Cleaning, Preserving, Sealing, Adhesive, and Related Materials Issued for Ordnance Materiel.	TM 9-850
Carburetors (Carter)	TM 9-1826A
Electrical Equipment (Auto-Lite)	TM 9-1825B
Electrical Equipment (Delco-Remy)	TM 9-8627
Fuel Pumps	TM 9-1828A
Hand, Measuring, and Power Tools	TM 10-590
Instruction Guide: Care and Maintenance of Ball and Roller Bearings.	TM 37-265
Lubrication	TM 9-2835
Maintenance and Care of Hand Tools	TM 9-867
Maintenance Responsibilities and Shop Operation	AR 750-5
Ordnance Expenditure for Repair of Transport Vehicles	SR 750-130-5
Modification of Ordnance Materiel	SB 9-38
Painting Instructions for Field Use	TM 9-2851
Preparation of Ordnance Materiel for Deep-Water Fording	TM 9-2853
Processing and Reconditioning of Antifriction Bearings	TB ORD 438
Tactical Motor Vehicle Inspections and Preventive Maintenance Services.	TM 9-2810
Wheeled and Half-Track Vehicles, Trailers, and Towed Artillery : Lubrication of Wheel Bearings.	TB 9-2835-12
¼-ton, 4 x 4 , Utility Truck, M38A1	TM 9-804A

f. Shipment and Stand-By or Long-Term Storage.

Army Shipping Document	TM 38-705
Instruction Guide : Ordnance Packaging and Shipping (Posts, Camps, and Stations).	TM 9-2854
Marking of Oversea Supply	SR 746-30-5
Military Standard—Marking of Shipments	MIL-STD-1291
Ordnance Storage and Shipment Chart—Group G	TB 9-OSSC-G
Preservation, Packaging, and Packing of Military Supplies and Equipment.	TM 38-230
Processing ^g of Motor Vehicles and Related Unboxed Materiel for Shipment and Storage.	SB 9-4
Processing of Unboxed and Unboxed Equipment for Oversea Shipment.	AR 747-30
Protection of Ordnance General Supplies in Open Storage	TB ORD 379
Standards for Oversea Shipment and Domestic Issue of Ordnance Materiel Other than Ammunition and Army Aircraft.	TB ORD 385
Report of Damaged or Improper Shipment	SR 745-45-5

Copies may be obtained from Aberdeen Proving Ground, Aberdeen, Md.

INDEX

	Paragraph	Page
Accessories:		
Installation -----	124	137
Removal -----	30	36
Accidents, reports of -----	3	6
Arm, rocker:		
Inspection and repair --	57	70
Installation -----	58	71
Removal -----	56	67
Bearing, connecting rod:		
Check clearance -----	104	117
Installation -----	104	117
Removal -----	47	51
Bearing, crankshaft. (See Bearing, main.)		
Bearing, front, camshaft:		
Inspection -----	50	52
Installation -----	52	57
Removal -----	50	52
Bearing, main:		
Check clearance -----	97	111
Installation of lower halves -----	96	108
Installation of upper halves -----	95	107
Removal -----	48	52
Bearing, pilot, clutch:		
Installation -----	70	82
Removal -----	70	82
Bearing, water pump shaft. (See Shaft, w/bearing, water pump.)		
Belt, fan and generator drive:		
Inspection -----	91	103
Installation -----	124	137
Removal ---	30	36
Belt tension adjusting brace. (See Brace, adjusting, belt tension.)		
Block, cylinder:		
Assembly -----	52	57
Cleaning -----	51	55
Disassembly -----	50	52
Inspection -----	51	55
Body, oil pump. (See Pump, oil.)		
Body, water pump. (See Pump, water.)		
Brace, adjusting, belt tension:		
Installation -----	124	137
Removal -----	31	40
Bracket, shaft, rocker arm:		
Inspection and repair --	57	70
Installation -----	58	71
Removal -----	56	67

	<i>Paragraph</i>	<i>Page</i>
Camshaft:		
Cleaning -----	66	82
Inspection -----	67	82
Installation -----	94	103
Removal -----	46	51
Camshaft driven gear. (See Gear, camshaft driven.)		
Camshaft front bearing. (See Bearing, front camshaft.)		
Camshaft thrust plate. (See Plate, thrust, camshaft.)		
Carburetor:		
Installation -----	124	137
Removal -----	30	36
Cleaning:		
General -----	24	33
Procedure -----	25	33
Clutch:		
Clip, pressure plate release lever:		
Installation -----	134	147
Removal -----	129	144
Cover, pressure plate:		
Assembly -----	133	146
Disassembly -----	130	145
Inspection -----	132	146
Installation -----	133	146
Removal -----	129	144
Cup, spring, pressure plate:		
Inspection -----	132	146
Installation -----	133	146
Removal -----	129	144
Data -----	128	144
Description -----	127	143
Disk, driven:		
Inspection -----	132	146
Installation -----	123	135
Removal -----	30	36
Repair -----	132	146
Facing, driven disk:		
Inspection -----	132	146
Installation -----	133	146
Removal -----	132	146
Lever, release pressure plate:		
Adjustment -----	123	135
Inspection -----	132	146
Installation -----	133	146
Removal -----	130	145
Pin, pivot, release lever:		
Installation -----	133	146
Removal -----	130	145
Plate, pressure w/cover assembly:		
Assembly -----	115	129
Disassembly -----	129	144
Inspection -----	132	146
Installation -----	123	135
Removal -----	30	36

Clutch—Continued.

	<i>Paragraph</i>	<i>Page</i>
Retainer, spring, auxiliary pressure:		
Inspection - - - - -	132	146
Installation - - - - -	133	146
Removal - - - - -	129	144
Spring, pressure:		
Inspection - - - - -	132	146
Installation - - - - -	133	146
Removal - - - - -	129	144
Spring, pressure auxiliary:		
Inspection - - - - -	132	146
Installation - - - - -	133	146
Removal - - - - -	129	144
Clutch pilot bearing. (See Bearing, pilot clutch.)		
Connecting rod. (See Rod, connecting.)		
Connecting rod bearings. (See Bearing, connecting rod.)		
Connector, ball check:		
Assembly - - - - -	140	157
Cleaning - - - - -	139	157
Disassembly - - - - -	138	155
Inspection - - - - -	139	157
Installation - - - - -	121	133
Operation - - - - -	137	153
Removal - - - - -	138	155
Cover, body, oil pump. (See Pump, oil.)		
Cover, exhaust valve spring compartment:		
Installation - - - - -	116	131
Removal - - - - -	44	48
Cover, pressure plate. (See Clutch.)		
Cover, rocker arm:		
Installation - - - - -	124	137
Removal - - - - -	32	42
Cover, timing gear:		
Assembly - - - - -	85	97
Cleaning - - - - -	84	96
Disassembly - - - - -	83	96
Inspection and repair - - - - -	84	96
Installation - - - - -	108	123
Removal - - - - -	37	45
Crankshaft:		
Cleaning - - - - -	64	81
Inspection - - - - -	65	81
Installation - - - - -	96	108
Removal - - - - -	48	52
Repair - - - - -	65	81
Crankshaft front oil seal. (See Seal, oil, front.)		
Crankshaft main bearing. (See Bearing, main.)		
Crankshaft rear oil seal. (See Seal, oil, rear main bearing.)		
Crankshaft thrust washer. (See Washer, thrust, crankshaft.)		
Cup, spring, pressure plate. (See Clutch.)		
Cushion, support, front mounting:		
Inspection - - - - -	92	103
Installation - - - - -	124	137
Removal - - - - -	40	47
Cylinder block. (See Block, cylinder.)		
Cylinder head. (See Head, cylinder.)		

	<i>Paragraph</i>	<i>Page</i>
Data, engine and clutch assembly - - -	5	16
Description, engine and clutch assembly - - - - -	4	7
Disk, driven, clutch. (See Clutch.)		
Distributor:		
Installation - - - - -	124	137
Removal - - - - -	30	26
Dowel pin, main bearing. (See Pin, dowel, main bearing.)		
End play, crankshaft, adjust - - - - -	107	121
Engine:		
Adjustments - - - - -	126	142
Construction - -	21	25
Data - - - - -	23	33
Description - - - - -	20	25
Disassembly into subassemblies - - -	30	36
Lubrication system - - - - -	22	31
Operation - - - - -	21	25
Run-in test - - - - -	126	142
Engine ground strap. (See Strap, engine ground.)		
Equipment, unsatisfactory, reports of - - - - -	3	6
Exhaust manifold. (See Manifold, exhaust.)		
Exhaust valve parts:		
Cap, rotator:		
Adjust cap to valve clearance - - - - -	87	98
Cleaning - - - - -	86	97
Inspection - - - - -	87	98
Installation - - - - -	105	120
Removal - - - - -	45	49
Guide:		
Installation - - - - -	51	55
Removal - - - - -	51	55
Lock, retainer:		
Cleaning - - -	86	97
Inspection - - - - -	87	98
Installation - - - - -	105	120
Removal - - - - -	45	49
Retainer, spring:		
Cleaning - - - - -	86	97
Inspection - - - - -	87	98
Installation - - - - -	105	120
Removal - - - - -	45	49
Spring:		
Cleaning - - - - -	86	97
Inspection - - - - -	87	98
Installation - - - - -	105	120
Removal - - - - -	45	49
Tappet:		
Cleaning - - - - -	62	80
Inspection - - - - -	63	80
Installation - - - - -	94	103
Removal - - - - -	49	52
Valve:		
Adjust cap to valve clearance - - - - -	87	98
Adjust clearance - - - - -	106	121
Cleaning - - - - -	86	97

Exhaust valve parts—Continued

Valve—Continued	Paragraph	Page
Inspection - - - - -	87	98
Installation - - - - -	105	120
Removal - - - - -	45	49
Repair - - - - -	87	98

Facing, disk, driven. (*See Clutch.*)

Fan and generator drive belt. (*See Belt, fan.*)

Fan and generator drive pulley. (*See Pulley, fan and generator drive.*)

Fan and water pump pulley. (*See Pulley, fan and water pump.*)

Filter, oil:

Installation - - - - -	124	137
Removal - - - - -	30	36

Flywheel:

Dowel, bolt - - - - -	70	82
Dowel, tapered - - - - -	70	82
Drill for dowel bolts - - - - -	70	82

Gear, ring:

Installation - - - - -	70	82
Removal - - - - -	70	82
Inspection - - - - -	69	82
Installation - - - - -	103	117
Removal - - - - -	41	47
Repair - - - - -	70	82

Forms - - - - - 3 - - - - 6

Front mounting plate. (*See Plate, mounting, front.*)

Fuel lines. (*See Lines, fuel.*)

Gear, camshaft driven:

Inspection - - - - -	90	102
Installation - - - - -	99	114
Removal - - - - -	38	45

Gear, crankshaft drive:

Inspection and repair - - - - -	90	102
Installation - - - - -	96	108
Removal - - - - -	39	47

Gear, drive, oil pump. (*See Pump, oil.*)

Generator:

Installation - - - - -	124	137
Removal - - - - -	30	36

Guide, valve, intake. (*See Intake valve parts.*)

Head, cylinder:

Assembly - - - - -	55	67
Cleaning - - - - -	54	61
Disassembly - - - - -	53	60
Inspection - - - - -	54	61
Installation - - - - -	112	127
Removal - - - - -	33	42
Repair - - - - -	54	61

Hook, lifting engine:

Installation - - - - -	112	127
Removal - - - - -	31	40

Impeller, water pump. (See Pump, water.)

	<i>Paragraph</i>	<i>Page</i>
Inspection:		
General -----	24	33
Procedure -----	27	35
Intake valve parts:		
Guide:		
Inspection -----	54	61
Installation -----	54	61
Removal -----	54	61
Lock:		
Cleaning -----	54	61
Inspection -----	54	61
Installation -----	55	67
Removal -----	53	60
Retainer:		
Cleaning -----	54	61
Inspection -----	54	61
Installation -----	55	67
Removal -----	53	60
Seal, oil, retainer:		
Installation -----	55	67
Removal -----	53	60
Spring:		
Cleaning -----	54	61
Inspection -----	54	61
Installation -----	55	67
Removal -----	53	60
Tappet:		
Cleaning -----	62	80
Inspection -----	63	80
Installation -----	94	103
Removal -----	49	52
Valve:		
Adjust clearance -----	114	129
Cleaning -----	54	61
Inspection -----	54	61
Installation -----	55	68
Removal -----	53	60
Repair -----	54	61
Jet, oil, timing gear:		
Installation -----	100	115
Removal -----	39	47
Lever, release, pressure plate. (See Clutch.)		
Lifting hook. (See Hook, lifting, engine.)		
Line, fuel:		
Installation -----	121	133
Removal -----	31	40
Line, oil:		
Installation -----	115	129
Removal -----	31	40
Line, vacuum:		
Installation -----	121	133
Removal -----	31	40

	<i>Paragraph</i>	<i>Page</i>
Lines, vent:		
Installation -----	121	133
Removal -----	31	40
Linkage, throttle:		
Installation -----	117	131
Removal -----	31	40
Maintenance allocation:		
Depot -----	2	6
Field -----	2	6
Manifold, exhaust:		
Inspection -----	88	101
Installation -----	122	134
Removal -----	31	40
Mark, matching, rear bearing cap -----	96	108
Mark, timing -----	99	114
Material, unsatisfactory reports of -----	3	6
Oil filler pipe. (<i>See Pipe, oil filler.</i>)		
Oil filter support. (<i>See Support, oil filter.</i>)		
Oil lines. (<i>See Line, oil.</i>)		
Oil pan. (<i>See Pan, oil.</i>)		
Oil pressure sending unit support. (<i>See Support, pressure sending unit.</i>)		
Oil pump. (<i>See Pump, oil.</i>)		
Oil seal, rear main bearing. (<i>See Seal, oil, rear main bearing.</i>)		
Oil strainer. (<i>See Strainer, oil.</i>)		
Packing, rear main bearing:		
Installation -----	96	108
Removal -----	48	52
Pan, oil:		
Cleaning -----	86	97
Inspection and repair -----	89	102
Installation -----	110	124
Removal -----	34	44
Parts -----	7	17
Parts, standard:		
Inspection and repair -----	93	103
Pin, dowel, main bearing:		
Installation in bearing cap -----	96	108
Installation in cylinder block -----	95	107
Removal -----	48	52
Pin, oil pump drive gear. (<i>See Pump, oil.</i>)		
Pin, piston:		
Inspection -----	60	73
Installation -----	61	77
Removal -----	59	72
Pin, pivot, release lever. (<i>See Clutch.</i>)		
Pipe, oil filler:		
Installation -----	124	137
Removal -----	31	40
Piston:		
Checking clearance of -----	60	73
Cleaning -----	60	73
Inspection -----	60	73
Selective fitting of -----	50	52

	<i>Paragraph</i>	<i>Page</i>
Piston and connecting rod assembly:		
Assembly -----	61	77
Cleaning -----	60	73
Disassembly -----	59	72
Installation -----	104	117
Removal -----	47	51
Piston pin. (See Pin, piston.)		
Plate, mounting front:		
Inspection -----	93	103
Installation -----	98	113
Removal -----	40	47
Plate, mounting, rear:		
Assembly -----	82	96
Cleaning -----	81	95
Disassembly -----	80	95
Inspection and repair -----	81	95
Installation -----	102	117
Removal -----	42	48
Plate, pressure. (See Clutch.)		
Plate, thrust, camshaft:		
Installation -----	94	103
Removal -----	46	51
Plugs, spark. (See Spark plugs.)		
Pulley, fan and generator drive:		
Installation -----	109	124
Removal -----	36	45
Pulley, fan and water pump. (See Pump, water.)		
Pump, fuel:		
Installation -----	119	133
Removal -----	30	36
Pump, oil:		
Assembly -----	79	92
Body:		
Cleaning -----	78	90
Inspection -----	78	90
Cover, body:		
Cleaning -----	78	90
Inspection -----	78	90
Installation -----	79	92
Removal -----	77	90
Disassembly -----	77	90
Gear, drive:		
Cleaning -----	78	90
Inspection -----	78	90
Installation -----	79	92
Removal -----	77	90
Installation -----	101	115
Pin drive gear:		
Installation -----	79	92
Removal -----	77	90
Removal -----	43	48
Retainer, relief valve spring:		
Cleaning -----	78	90
Inspection -----	78	90
Installation -----	79	92
Removal -----	77	90

Pump, oil—Continued

	<i>Paragraph</i>	<i>Page</i>
Rotor, inner, w/shaft:		
Cleaning -----	78	90
Inspection -----	78	90
Installation -----	79	92
Removal -----	77	90
Rotor, outer:		
Cleaning -----	78	90
Inspection -----	78	90
Installation -----	79	92
Removal -----	77	90
Shaft, drive. (See Rotor, inner w/shaft.)		
Shim, pressure relief valve:		
Installation -----	79	92
Removal -----	77	90
Spring, pressure relief valve:		
Cleaning -----	78	90
Inspection -----	78	90
Installation -----	79	92
Removal -----	77	90
Valve, relief, pressure:		
Cleaning -----	78	90
Inspection -----	78	90
Installation -----	79	92
Removal -----	77	90
Pump, water:		
Assembly -----	76	88
Bearing. (See Shaft, w/bearing.)		
Body:		
Cleaning -----	75	87
Inspection -----	75	87
Repair -----	75	87
Disassembly -----	74	85
Impeller:		
Cleaning -----	75	87
Inspection -----	75	87
Installation -----	76	86
Removal -----	74	85
Installation -----	111	125
Pulley:		
Installation -----	76	88
Removal -----	74	85
Removal -----	30	36
Seal:		
Installation -----	76	88
Removal -----	74	85
Shaft, w/bearing:		
Inspection -----	75	87
Installation -----	76	88
Removal -----	74	85
Spring, retaining bearing:		
Installation -----	76	88
Removal -----	74	85
Washer, seal:		
Cleaning -----	75	87

Pump, water—Continued

Washer, seal—Continued

	<i>Paragraph</i>	<i>Page</i>
Inspection -----	75	87
Installation -----	76	88
Removal -----	74	85
Rear main bearing packing. (See Packing, rear main bearing.)		
Records -----	3	6
Repair:		
General -----	24	33
Procedures -----	28	35
Reports -----	3	6
Retainer, spring, auxiliary pressure. (See Clutch.)		
Ring, compression:		
Gap setting -----	61	77
Installation -----	61	77
Removal -----	59	72
Ring, oil control:		
Gap setting -----	61	77
Installation -----	61	77
Removal -----	59	72
Rocker arm. (See Arm, rocker.)		
Rocker arm and shaft assembly:		
Assembly -----	58	71
Disassembly -----	56	67
Installation -----	113	128
Removal -----	32	48
Rocker arm cover. (See Cover, rocker arm.)		
Rocker arm shaft. (See Shaft, rocker arm.)		
Rocker arm shaft bracket. (See Bracket, shaft, rocker arm.)		
Rocker arm shaft spring. (See Spring, rocker arm shaft.)		
Rod, connecting:		
Assemble to piston -----	61	77
Cleaning -----	60	73
Disassemble from piston -----	59	72
Inspection and repair -----	60	73
Rotor, inner, oil pump. (See Pump, oil.)		
Rotor, outer, oil pump. (See Pump, oil.)		
Seal, oil, front:		
Installation -----	85	97
Removal -----	83	96
Seal, oil, rear main bearing:		
Installation -----	95	107
Removal -----	48	52
Seal, water pump. (See Pump, water.)		
Sending unit, oil pressure. (See Unit, sending oil pressure.)		
Sending unit, water temperature. (See Unit, sending, water temperature.)		
Shaft, rocker arm:		
Inspection -----	57	70
Installation -----	58	71
Removal -----	56	67
Shaft, w/bearing, water pump. (See Pump, water.)		
Shaft, w/inner rotor. (See Pump, oil.)		

	<i>Paragraph</i>	<i>Page</i>
Shield, fan and generator drive pulley:		
Installation -----	110	124
Removal -----	34	44
Shim, adjusting, crankshaft and play:		
Installation -----	96	108
Rem oval -----	48	52
Shim, oil pump pressure relieve valve. (See Pump, oil.)		
Slinger, crankshaft, oil:		
Installation -----	107	121
Removal -----	37	45
Spacer, camshaft, thrust plate:		
Installation -----	94	103
Removal -----	46	51
Spacer, gear, drive, crankshaft:		
Installation -----	107	121
Removal -----	37	45
Spark plugs:		
Installation -----	124	137
Removal -----	30	36
Spring, oil pump pressure relief valve. (See Pump, oil.)		
Spring, pressure, auxiliary. (See Clutch.)		
Spring, pressure, clutch. (See Clutch.)		
Spring, rocker arm shaft:		
Installation -----	58	71
Removal -----	56	67
Standard parts. (See Parts, standard.)		
Starter:		
Installation -----	124	137
Removal -----	30	36
Strainer, oil:		
Assembly -----	73	84
Cleaning -----	72	84
Disassembly -----	71	84
Inspection -----	72	84
Installation -----	110	124
Removal -----	35	44
Strap, ground:		
Installation -----	124	137
Removal -----	31	40
Support, mounting, generator:		
Installation -----	124	137
Removal -----	31	40
Support, oil filter:		
Installation -----	112	127
Removal -----	31	40
Support, oil pressure sending unit:		
Installation -----	124	137
Removal -----	31	40
Support, rear mounting plate:		
Cleaning -----	81	95
Inspection and repair -----	81	95
Installation -----	82	96
Removal -----	80	95

	<i>Paragraph</i>	<i>Page</i>
Support, starter:		
Installation - - - - -	124	137
Removal - - - - -	31	40
Test, engine - - - - -	125	142
Throttle linkage. (See Linkage, throttle.)		
Timing gear. (See Gear, camshaft driven, and Gear, crankshaft drive.)		
Timing gear cover. (See Cover timing gear.)		
Tools:		
Common, and equipment - - - - -	8	17
Special - - - - -	9	17
Troubleshooting:		
Carbon, excessive - - - - -	18	24
Compression, low - - - - -	16	23
General - - - - -	12	22
Ignition - - - - -	15	23
Oil consumption, excessive - - - - -	19	24
Procedures - - - - -	11	21
Underwater ventilating system. (See Ventilating system.)		
Unit, sending, oil pressure:		
Installation - - - - -	124	137
Removal - - - - -	30	36
Unit, sending, water temperature:		
Installation - - - - -	124	137
Removal - - - - -	30	38
Vacuum line. (See Line, vacuum.)		
Valve, metering:		
Assembly - - - - -	140	157
Cleaning - - - - -	139	157
Description - - - - -	136	151
Disassembly - - - - -	138	155
Inspection - - - - -	139	157
Installation - - - - -	140	157
Removal - - - - -	138	155
Valve, pressure relief, oil pump. (See Pump, oil.)		
Valve, vent control, lower crankcase:		
Assembly - - - - -	140	157
Cleaning - - - - -	139	157
Disassembly - - - - -	138	155
Operation over-land service - - - - -	136	151
Operation underwater service - - - - -	137	153
Inspection - - - - -	139	157
Installation - - - - -	140	157
Removal - - - - -	138	155
Valve, vent control, upper crankcase:		
Assembly - - - - -	140	157
Cleaning - - - - -	139	157
Disassembly - - - - -	138	155
Operation over-land service - - - - -	136	151
Operation underwater service - - - - -	137	153
Inspection - - - - -	139	157
Installation - - - - -	140	157
Removal - - - - -	138	155
Vent line. (See Lines, vent.)		

c

DEPARTMENT OF THE ARMY TECHNICAL MANUAL
DEPARTMENT OF THE AIR FORCE TECHNICAL ORDER
ENGINE (WILLYS-OVERLAND MODEL MD) AND CLUTCH
FOR **¼-TON** 4 x 4 UTILITY TRUCK M38A1 AND **¼-TON**
4 x 4 FRONT LINE AMBULANCE M170

TM 9-8015-1
TO 38Y2-7-2
CHANGES No. 1

DEPARTMENTS OF THE ARMY
AND THE AIR FORCE
WASHINGTON 25, D. C., .11 April 1955

TM 9-8015-1/TO 19-75B-21, 8 March 1954, is changed as follows :
The title is changed to read

ENGINE (WILLYS-OVERLAND MODEL MD) AND
CLUTCH FOR **¼-TON** 4 x 4 UTILITY TRUCK M38A1 AND
¼-TON 4 x 4 FRONT LINE AMBULANCE M170

1. Scope

* * * * *

b. This manual contains * * utility truck M38A1 and the **¼-ton**
4 x 4 front line ambulance M170. The appendix contains * * * to
the materiel.

* * * * *

5. Data

* * * * *

Used in vehicle models - - - - - M38A1 and M170.

* * * * *

70. Repair

* * * * *

c. If the old * * * crankshaft as follows :

(1) Assemble the flywheel * * * the nuts securely. Refer to
paragraph 152 for torque specifications.

* * * * *

92.1 *Fan and Generator Drive Pulley*

(added)

a. *Inspection.* Inspect the fan and generator drive pulley (AU,
fig. 12), and if pulley inside flanges shows signs of having separated
at the hub, repair as outlined in b below.

b. *Repair.*

(1) Locate the centers for three holes on the pulley so that they
will be on a circle 2½ inches in diameter, the center of which
lies on the centerline of the pulley. Space the holes so that
they will be 120° apart.

Caution: Absolute accuracy of spacing is necessary to prevent throwing the pulley out of balance.

- (2) Drill three $\frac{1}{4}$ -inch holes at the locations indicated in (1) above.
- (3) Rivet securely with three $\frac{1}{4} \times \frac{7}{16}$ flat-head steel rivets.

147. Pistons and Rings

(pars. 60 and 61)

b. (Superseded) Rings.

Fig. Ref. letter	Point of measurement	Sizes and fits of new parts		
		Minimum	Maximum	Wear limits
123	C Thickness of compression rings (2)	0. 0930	0. 0935	-----
	B Thickness of oil ring (1)	0. 186	0. 1865	-----
122	---- Top ring to groove clearance	0. 002	0. 0035	0. 005
	Center ring to groove clearance	0. 0015	0. 0030	0. 0045
	Bottom ring to groove clearance	0. 001	0. 0025	0. 0045
	Ring gap in cylinder block	0. 007	0. 023	0. 040

[AG 451.2 (23 Mar 55)]

BY ORDER OF ~~THE~~ SECRETARIES OF THE ARMY AND ~~THE AIR~~ FORM:

M. B. RIDGWAY,
General, United States Army,
Chief of Staff.

OFFICIAL :

JOHN A. KLEIN,
Major General, United States Army,
The Adjutant General.

N. F. TWINING,
Chief of Staff, United States Air Force.

OFFICIAL :

E. E. TORO,
Colonel, United States Air Force,
Air Adjutant General.

DISTRIBUTION :

Active Army:

Tec Svc, DA (1)
Ord Bd (2)
CONARC (3)
Army AA Comd (2)
OS Mai Comd (5)
OS Base Comd (2)
Log Comd (3)
MDW (1)
Armies (3)
Corps (2)
Div (2)
Ord **Gp** (2)
Ord Bn (2)
Ord Co (2)
Ft & Cp (2)
Gen & Br *Svc* Sch (2)
Ord Sch (50)
PMST Ord ROTC units (1)
Gen Depots (2)
Ord Sec, Gen Depots (5)
Ord Depots (10)
POD (2)
OS Sup Agencies (1)
ORD PG (10)
Ord Arsenals (5)

MR Dist (1)
Ord Proc Dist (10)
MAAG (1)
Mil Msn (1)
Units organized under following TOE'S :
9-12A, Hq & Hq Co, Maint & Sup Co Ammo (1)
9-17, Ammo Co, Army (1)
9-45A, Sp Wpn Spt or Depot Bn (1)
9-46A, Hq & Hq Det, Sp Wpns Spt or Depot Bn (1)
9-47A, Sp Wpns Spt or Depot Co (1)
9-49, Sp Wpns Dir Spt Co (1)
9-57A, Fld Sup Co (1)
9-229, ORD GM Dir Spt Co (1)
9-347, Ord Tire Rebuild Co (1)
9-367, Sup Depot Co (1)
9-387, Ammo Depot Co (1)

NG: Same as Active Army except allowance is one copy to each unit.

USAR: None.

For explanation of abbreviations used, see SR 320-50-1.